

Nguyen Duc Thang

3200 ANIMATED MECHANICAL MECHANISMS

With

**Images,
Brief explanations
and YouTube links**

Part 2

Other kinds of motion transmission

31 March 2020

This document is divided into 4 parts.
Part 1: Transmission of continuous rotation
Part 2: Other kinds of motion transmission
Part 3: Mechanisms of specific purposes
Part 4: Mechanisms for various industries

Autodesk Inventor is used to create all videos in this document.
They are available on YouTube channel “thang010146”.

To bring as many as possible existing mechanical mechanisms into this document is author’s desire. However it is obstructed by author’s ability and Inventor’s capacity. Therefore from this document may be absent such mechanisms that are of complicated structure or include flexible and fluid links.

This document is periodically renewed because the video building is continuous as long as possible. The renewed time is shown on the first page.

This document may be helpful for people, who
- have to deal with mechanical mechanisms everyday
- see mechanical mechanisms as a hobby

Any criticism or suggestion is highly appreciated with the author’s hope to make this document more useful.

Author’s information:

Name: Nguyen Duc Thang
Birth year: 1946
Birth place: Hue city, Vietnam
Residence place: Hanoi, Vietnam
Education:

- Mechanical engineer, 1969, Hanoi University of Technology, Vietnam
- Doctor of Engineering, 1984, Kosice University of Technology, Slovakia

Job history:

- Designer of small mechanical engineering enterprises in Hanoi.
- Retirement in 2002.

Contact Email: thang010146@gmail.com



Table of Contents

2. Converting continuous rotation into interrupted rotation	4
2.1. Tooth-uncompleted gears	4
2.2. Geneva drives	15
2.3. Ratchet drives	26
2.4. Pin drives.....	39
2.5. Bars.....	45
2.6. Combined mechanisms	46
3. Converting continuous rotation into rotary oscillation	49
3.1. Bars.....	49
3.2. Gears	60
3.3. Cams.....	63
3.4. Belts and cables	66
3.5. Combined mechanisms	68
4. Altering rotary oscillations	75
5. Converting continuous rotation into linear motion.....	82
5.1. Bars.....	82
5.2. Gears	100
5.3. Bars and gears	105
5.4. Cams.....	116
5.5. Chains	128
5.6. Friction drives	130
6. Converting rotary oscillation into linear motion and vice versa	131
6.1. Gears	131
6.2. Bars, cams	139
6.3. Screws	143
6.4. Belts and cables	150
7. Rotation to wobbling motion	154
8. Altering linear motions	157
8.1. Bars, wedges and cams	157
8.2. Gear drives.....	169
8.3. Chains, belts and cables.....	174
9. Converting reciprocating motion into continuous rotation.....	180
9.1. Converting reciprocating rotation into continuous rotation.....	180
9.2. Converting reciprocating linear motion into continuous rotation	188
10. Mechanisms for creating complicated motions	192
10.1. Planar motions.....	192
10.2. Spatial motions	197
11. Study of mechanisms	203
11.1. Mechanical joints	203
11.2. Planar mechanisms	208
11.3. Spatial mechanisms	215
11.4. Springs	223

2. Converting continuous rotation into interrupted rotation

2.1. Tooth-uncompleted gears

Transmission with teeth-uncompleted gears 1a

<http://www.youtube.com/watch?v=AtoqZKDH-fY>

The blue driving gear is a teeth-uncompleted one.

Its number of remained teeth $Z1c = 1$

Its number of teeth (teeth-completed) $Z1 = 40$

Its number of cut-off teeth $Z1f = Z1 - Z1c = 39$.

The number of the green driven gear (teeth-completed) $Z2 = 20$

When the blue makes 1 revolution, the green makes $3/20$ revolution.

Avoid wrong calculation:

When the blue makes 1 revolution, the green makes $Z1c/Z2$ revolution.

For this case it means when the blue makes 1 revolution, the green makes $1/20$ revolution (!).

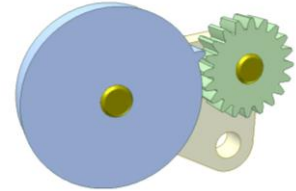

Transmission with teeth-uncompleted gears 1b

<https://youtu.be/8lNxCUpZH8k>

Input: large gear (teeth-uncompleted), rotating continuously.

Its number of teeth (teeth-completed) $Z1$

Its number of remained teeth $Z1c$

Tops of two end teeth are cut off for meshing start.

Output: small gear rotating interruptedly.

Its number of teeth $Z2$

In 1 revolution of the input, the output turns A deg. and then pauses.

For this video: $Z1 = 40$; $Z1c = 9$; $Z2 = 20$; $A = 180$ deg.

Alter $Z1c$ from 1 to 37 to get other value of A from 36 deg. to 684 deg. (increasing step: 18 deg.)

The small gear is kept immobile during its pause stages thanks to no teeth sector of the large gear.

For more about the mechanism calculation refer to

<http://www.youtube.com/watch?v=AtoqZKDH-fY>

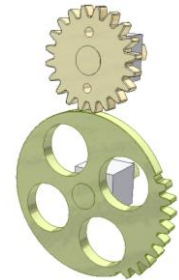

Transmission with teeth-uncompleted gears 2

<http://youtu.be/YNsSa9hSw4A>

A funny mechanical problem:

There is a drive of two gears of 20 teeth each.

What is the motion of the driven gear if 1 tooth of the driving gear is broken?

Wrong answer: 1 revolution of the driving gear corresponds $19/20$ revolution of the driven gear.

Correct answer:

The driven gear rotates as if the tooth was not broken, because if the driving gear has only 1 tooth, it makes the driven gear move 2 teeth.

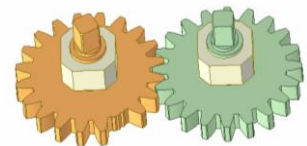

Transmission with teeth-uncompleted gears 3

<http://youtu.be/zSTqwxXCR9M>

Input: the orange gear.

Its number of remained teeth $Z1c = 5$

Its number of teeth (teeth-completed) $Z1 = 18$

Its number of cut-off teeth $Z1f = Z1 - Z1c = 13$

Output: the green gear.

Its number of teeth (teeth-completed) $Z2 = 18$.

When the orange makes 1 revolution, the green makes $1/3$ revolution.



Transmission with teeth-uncompleted gears 4

<http://youtu.be/LkweQilGCRs>

Input: the yellow gear.

Its number of remained teeth $Z1c = 2$

Its number of teeth (teeth-completed) $Z1 = 20$

Its number of cut-off teeth $Z1f = Z1 - Z1c = 18$

Output: the green gear.

It has 14 tooth slots.

Its number of teeth (teeth-completed) $Z2 = 21$.

When the yellow makes 1 revolution, the green makes $1/7$ revolution.

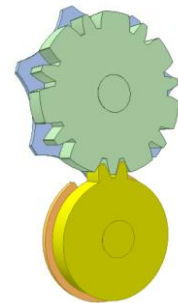

Transmission with teeth-uncompleted gears 5

<http://youtu.be/ebMgECUuHdg>

Input: the yellow gear.

Its number of remained teeth $Z1c = 1$

Its number of teeth (teeth-completed) $Z1 = 20$

Its number of cut-off teeth $Z1f = Z1 - Z1c = 19$

Output: the green gear.

It has 10 tooth slots.

Its number of teeth (teeth-completed) $Z2 = 20$.

When the yellow makes 1 revolution, the green makes $1/10$ revolution.

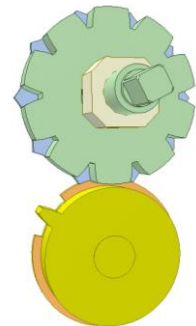

Transmission with teeth-uncompleted gears 8a

<http://youtu.be/wPxQOsEiJ2E>

Input: the yellow gear.

Its number of remained teeth $Z1c = 9$

Its number of teeth (teeth-completed) $Z1 = 20$

Its number of cut-off teeth $Z1f = Z1 - Z1c = 11$

Output: the green gear.

Its number of teeth (teeth-completed) $Z2 = 20$.

When the yellow makes 1 revolution, the green makes $1/2$ revolution.

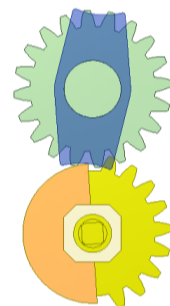

Transmission with teeth-uncompleted gears 10a

<http://youtu.be/scBbYOlmjUo>

Input: the yellow gear.

Its number of remained teeth $Z1c = 18$

Its number of teeth (teeth-completed) $Z1 = 40$

Its number of cut-off teeth $Z1f = Z1 - Z1c = 22$

Output: the green gear.

Its number of teeth (teeth-completed) $Z2 = 20$.

When the yellow makes 1 revolution, the green makes 1 revolution and pause during $\frac{1}{2}$ revolution of the yellow.

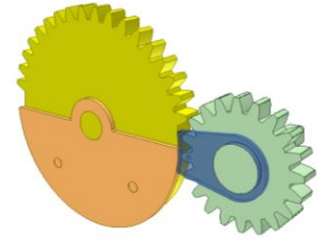

Transmission with teeth-uncompleted gears 18a

<http://youtu.be/lj8J37zluhU>

Input: the blue gear.

Its original number of teeth $Z1 = 16$

Output: the green gear

Its original number of teeth $Z2 = 28$

When the blue makes 1 revolution, the green turns two times and pauses two times.

The arcs on both gear keep the output gear immobile during its pause period.

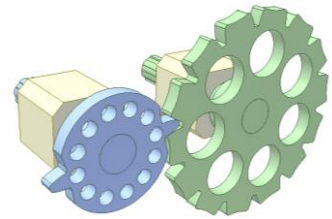

Transmission with teeth-uncompleted gears 19c

<http://youtu.be/NmiXFGb-dD8>

The blue gear is fixed. The orange gear is a satellite.

Input is the yellow crank.

In 1 revolution of the crank, the orange turns two times and pauses two times.

The arcs on both gear keep the orange gear immobile during its pause period.

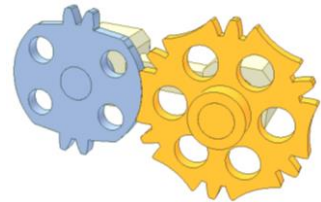

Transmission with teeth-uncompleted gears 17

http://youtu.be/_7ifFtlc5t8

A measure to ensure proper engagement (jam avoiding).

Input: the pink gear.

Its number of remained teeth $Z1c = 30$

Its original number of teeth $Z1 = 40$

Its number of cut-off teeth $Z1f = Z1 - Z1c = 10$

The blue gear sector has 4 teeth (Zs)

Output: the yellow gear of $Z2 = 20$ teeth.

When the pink makes 1 revolution, the yellow makes $(Z1c + Zs + A)/Z2 = (30 + 4 + 2)/20 = 36/20 = 1.8$ revolution and pause during $(40 - 36)/40 = 1/10$ revolution of the pink.

Why $A = 2$? If the pink gear has only 1 tooth and the blue gear sector is absent so when the pink makes 1 revolution, the yellow makes $3/20$ revolution.

Measure to keep the output gear immobile during its pause is not shown.

Disadvantage: Pause time can not be long.

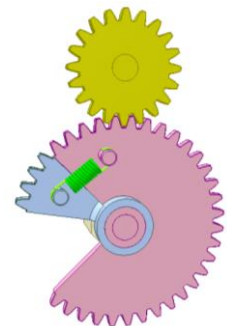

Transmission with teeth-uncompleted gears 19b

<http://youtu.be/5nCJj2hxpUs>

Input: the blue gear.

Its original number of teeth $Z_1 = 20$

Output: the green gear

Its original number of teeth $Z_2 = 24$

When the blue makes 1 revolution, the green turns two times and pauses two times.

The arcs on both gear keep the output gear immobile during its pause period.

The yellow star, red spring and two pink pins are used for reducing shock. Before teeth engagement, the pink pin pushes the star. The latter pulls the output blue gear through the spring and gives the output a low initial speed.

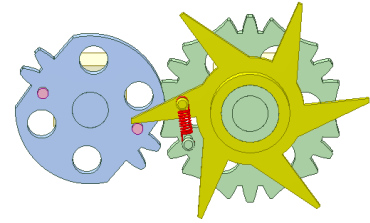

Transmission with teeth-uncompleted gears 20a

<http://youtu.be/CQTx412p6nI>

Input: the green gear.

Its original number of teeth $Z_1 = 24$

Output: the blue gear

Its original number of teeth $Z_2 = 19$

In one rev. of the input, the output turns 1 rev. and then pauses.

The arcs on both gear keep the output gear immobile during its pause period.

The pink and orange bars give the output an added rotation before the teeth engagement.

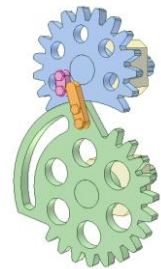

Transmission with teeth-uncompleted gears 21

<http://youtu.be/RIVk2eYRw3Q>

Input: the green gear of 1 tooth.

Its original number of teeth $Z_1 = 16$

Output: the pink gear of $Z_2 = 16$ teeth

In one rev. of the input, the output turns $1/8$ rev. and then pauses.

The yellow pin of the blue arm keeps the output immobile during its pause period. The pin on the input controls the blue arm.

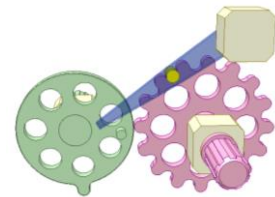

Transmission with teeth-uncompleted gears 22

<http://youtu.be/PZ54x2hgU9A>

Input: yellow gear of tooth number $Z_i = 18$.

Output: green teeth-uncompleted gear.

Its tooth number (teeth-completed) $Z_o = 20$

Its number of remained teeth $Z_{oc} = 17$

Its number of cut-off teeth $Z_{of} = Z_o - Z_{oc} = 3$.

When the input turns 2 revolutions, the output turns 1 revolution and has long dwell (time of 1 input revolution).

The key concept: Z_i is less than Z_o

Measure to keep the output immobile during its dwell is not shown.

The unusualness for this mechanism is that the input is a tooth completed gear. Not like in ordinary drive: the input is the teeth-uncompleted gear.

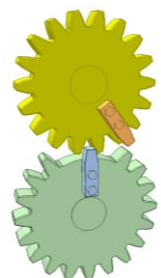

Transmission with teeth-uncompleted gears 1c

<https://youtu.be/gYm8mNCNZkE>

Input: large gear (teeth-uncompleted), rotating continuously.

Its number of teeth (teeth-completed) $Z_1 = 35$

Its number of remained teeth: $4 + 4 + 9$

Its number of cut-off teeth: $6 + 6 + 6$

Tops of two end teeth of each tooth group are cut off for meshing start.

Output: small gear of 20 teeth rotating interruptedly.

1 revolution of the input corresponds to 1 revolution of the output.

In one revolution the output turns 90 deg., pauses, turns 90 deg.,

pauses, turns 180 deg., pauses.

The output gear is kept immobile during its pause stages thanks to no teeth sector of the input gear.

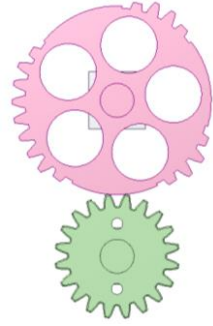

Transmission with teeth-uncompleted gears 20b

<https://youtu.be/JiVVwG-YUg4>

Input: large gear (tooth-uncompleted) rotating continuously.

Output: small gear (tooth-uncompleted) that performs interrupted rotation.

In 1 input revolution it turns 360 deg. (with the support of the pink lever and violet pin) and dwells (thanks to flat (no teeth) section of the large gear).

The original small gear (tooth-completed) has 10 teeth.

The original large gear (tooth-completed) has 16 teeth.

Increase the large gear diameter for a larger dwell/motion time ratio of the output.

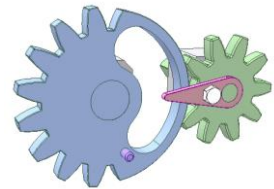

Indexing mechanism 6 (180 deg.)

<https://youtu.be/WM3roJbzX7U>

Input: large gear (tooth-uncompleted) rotating continuously.

Output: small gear (tooth-uncompleted) that performs interrupted rotation.

In 1 input revolution it turns 180 deg. (with the support of the pink lever and violet pin) and dwells (thanks to flat (no teeth) section of the large gear).

The original small gear (tooth-completed) has 10 teeth.

The original large gear (tooth-completed) has 16 teeth.

Increase the large gear diameter for a larger dwell/motion time ratio of the output.

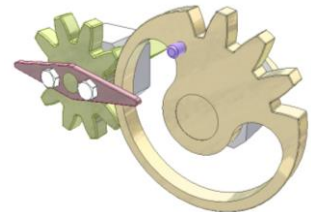

Interrupted rotation of satellite gear 3

<https://youtu.be/T863RDCdgHg>

Input: yellow crank rotating continuously.

Output: green satellite gear that performs interrupted rotation.

In 1 input revolution it quickly flips 180 deg. (with the support of pink lever and violet pin) and keeps that direction until the next flip (thanks to flat (no teeth) section of the grey fixed gear).

The original green gear (tooth-completed) has 10 teeth.

The original grey gear (tooth-completed) has 32 teeth.

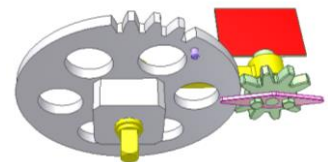

Transmission with teeth-uncompleted gears 10b

<http://youtu.be/CZhhw9hGUms>

Input: pink shaft.

Output: grey and blue gears.

The grey gear rotates continuously two times faster than the input.

The blue gear rotates interruptedly with the same direction and velocity of the grey gear. When the grey gear makes 2 rev., the blue gear makes 1 rev. and pause during 1 rev. of the grey gear.

For pink gear fixed to the pink shaft:

Its number of remained teeth $Z1c = 18$

Its number of teeth (teeth-completed) $Z1 = 40$

Its number of cut-off teeth $Z1f = Z1 - Z1c = 22$

Orange gear of 40 teeth is fixed to the pink shaft.

Tooth number of remained gears: 20

Light green gear is fixed to the green gear shaft.

Yellow gear (for reverse purpose) is in mesh with both light green and blue gears.

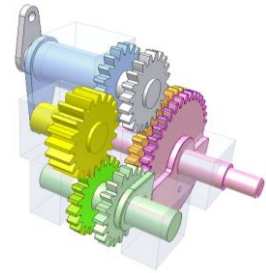

Interrupted rotation 12

https://youtu.be/HHLIT6_Brs

Input: violet pin gear rotate continuously.

One revolution of the violet gear makes the blue pin gear rotate interruptedly one tenth of a revolution thanks to two red pins of the violet gear and orange pinion of 8 teeth.

The blue gear of 20 pins and the pinion are always in mesh.

Four teeth of the pinion are longer than the remainings. In combination with the outside diameter of the violet gear, they keep the pinion and the blue gear immobile when the above mentioned two pins are not in mesh.

The blue pin gear can be replaced with an ordinary spur gear. See:

<https://www.youtube.com/watch?v=rjWfliaOFR4>

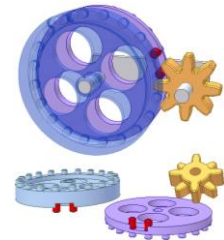

Transmission with teeth-uncompleted gears 23

<http://youtu.be/anoaPGu2QMI>

Input: yellow shaft of constant velocity

Output: blue shaft having two velocities (transmission ratio $i = 20/10$ and $12/18$) in its every revolution.



Transmission with teeth-uncompleted gears 6

http://youtu.be/31vVO_i8WO8

Input: the orange gear.

Its number of remained teeth $Z1c = 1$

Its number of teeth (teeth-completed) $Z1 = 20$

Its number of cut-off teeth $Z1f = Z1 - Z1c = 19$

Output: the green gear.

It has 12 tooth slots.

Its number of teeth (teeth-completed) $Z2 = 60$.

When the orange makes 1 revolution, the green makes 1/12 revolution.

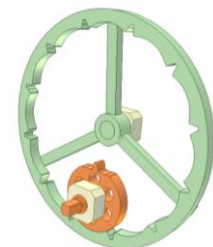

Transmission with teeth-uncompleted gears 9

<http://youtu.be/p04ZgliBLVY>

Input: the orange gear.

Its number of remained teeth $Z1c = 1$

Its number of teeth (teeth-completed) $Z1 = 20$

Its number of cut-off teeth $Z1f = Z1 - Z1c = 19$

Output: the green gear.

Its number of teeth (teeth-completed) $Z2 = 36$.

When the orange makes 1 revolution, the green makes $1/6$ revolution.

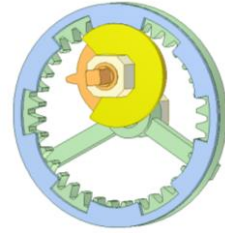

Transmission with teeth-uncompleted gears 7

<http://youtu.be/YzIYI4ssr9I>

Planetary drive with dwell.

R1: pitch diameter of the green gear having 20 teeth.

R2: pitch diameter of the yellow gear having 20 teeth.

R3: pitch diameter of the orange gear having 1 tooth.

R4: pitch diameter of the blue internal gear having 12 tooth slots.

$R1 = R2 = R3$; $R4 = 3R1$

The green gear is input.

The output pink crank carrying the yellow and orange gear block rotates with periodical pauses.

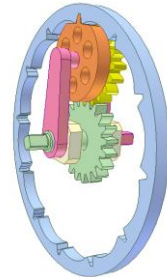

Transmission with teeth-uncompleted gears 8b

<http://youtu.be/OeIDzgpOu0>

Input: pink gear shaft.

Its number of remained teeth $Z1c = 9$

Its number of teeth (teeth-completed) $Z1 = 20$

Its number of cut-off teeth $Z1f = Z1 - Z1c = 11$

The blue gear (teeth-completed) has $Z2 = 20$ teeth.

When the pink makes 1 revolution, the blue makes $1/2$ revolution.

Glass disk is fixed to the blue shaft. Orange circular slider is fixed to the disk by red screw (pushing on bottom of the dovetail groove). Violet slider reciprocates with dwells at both ends of its stroke. It is possible to get dwell at middle of the stroke by adjusting position of the circular slider on the disk.

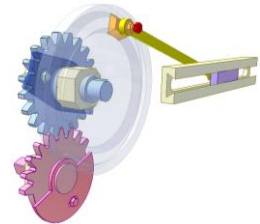

Transmission with teeth-uncompleted gears 10b

<http://youtu.be/GmwCj5u2GUE>

Input: pink gear shaft.

Its number of remained teeth $Z1c = 18$

Its number of teeth (teeth-completed) $Z1 = 40$

Its number of cut-off teeth $Z1f = Z1 - Z1c = 22$

The green gear (teeth-completed) has $Z2 = 20$ teeth.

When the input makes 2 revolutions, the green makes 1 revolution and pause during $1/2$ revolution of the input.

Glass disk is fixed to the green shaft. Blue circular slider is fixed to the disk by red screw (pushing on bottom of the dovetail groove). Violet slider reciprocates with dwells at one end (right or left) of its stroke.

The video shows how to change dwell position (from right end to left one) by adjusting position of the circular slider on the disk.

It is possible to set dwell position of the violet slider anywhere on its stroke.

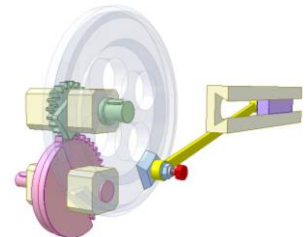

Skew teeth-uncompleted gear drive 1a

<http://youtu.be/ePdEwNcnolo>

Input: yellow gear rotating continuously.

Output: blue gear rotating interruptedly.

For the yellow gear:

Its number of remained teeth $Z1c = 12$ (180 deg.)

Its number of teeth (teeth-completed) $Z1 = 24$

Its number of cut-off teeth $Z1f = Z1 - Z1c = 12$ (180 deg.).

There is an orange rim located in the place, where the teeth are cut off.

The number of the blue gear (teeth-completed) $Z2 = 24$.

It has two red triangular slots.

The rim and slots are for keeping the blue gear immobile during its dwell.

When the yellow makes 1 revolution, the blue makes an angle $A = 1/2$ revolution.

Alter $Z1$, $Z1c$ and $Z2$ to get various values of A .

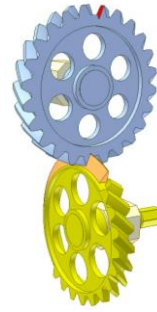

Skew teeth-uncompleted gear drive 1b

<http://youtu.be/iBr34hiWXNE>

Input: lower gear rotating continuously.

Output: upper gear rotating interruptedly.

For the lower gear:

Its number of remained teeth $Z1c = 3$ (45 deg.)

Its number of teeth (teeth-completed) $Z1 = 24$

Its number of cut-off teeth $Z1f = Z1 - Z1c = 21$ (315 deg.)

There is a pink rim located in the place, where the teeth are cut off.

The number of the upper gear (teeth-completed) $Z2 = 24$.

It has eight red triangular slots.

The rim and slots are for keeping the upper gear immobile during its dwell.

When the yellow makes 1 revolution, the blue makes an angle $A = 1/8$ revolution.

Alter $Z1$, $Z1c$ and $Z2$ to get various values of A .



Teeth-uncompleted bevel gears 1a

<https://youtu.be/u37W9bZIm1Q>

Input: large gear (teeth-uncompleted), rotating continuously.

Its number of teeth (teeth-completed) $Z1$

Its number of remained teeth $Z1c$

Tops of two end teeth are cut off for easy meshing start.

Output: small gear rotating interruptedly.

Its number of teeth $Z2$

In 1 revolution of the input, the output turns A deg. and then pauses.

For this video: $Z1 = 32$; $Z1c = 3$; $Z2 = 16$; $A = 90$ deg.

Alter $Z1c$ to get other value of A .

The small gear is kept immobile during its pause stages thanks to no teeth sector of the large gear.

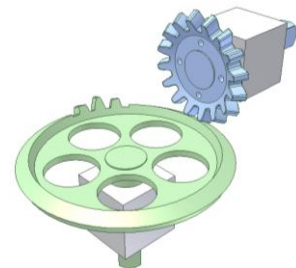

Teeth-uncompleted bevel gears 1b

<https://youtu.be/0JMF5Op6984>

Input: green carrier, 180 deg. reciprocating.

Output: blue gear, 180 deg. reciprocating.

During 180 deg. rotation of the input, the output turns 180 deg. and then pauses or vice versa.

White gear is stationary.

No teeth sector of the large gear keeps the blue gear immobile during its pause stages.

It can be used for the gate shown at

<https://youtu.be/P32pBR-HRa0>

when the opening angle is larger than 90 deg.

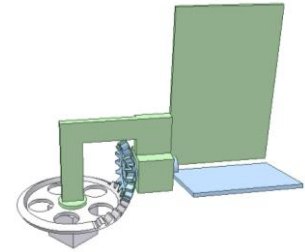

Mechanism for converting continuous rotation into 90 deg. oscillation to both sides with dwells 3

<http://youtu.be/D-HU11eBDjU>

Input: teeth-uncompleted face gear.

Output motion of horizontal shaft: Neutral rest - Turn left 90 deg. –

Left rest - Return – Neutral rest - Turn right 90 deg. – Right rest – Return.

Pay attention to the risk of jam if no positioning device for the output during its dwells.

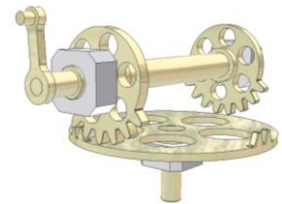

Bevel gears for interrupted rotation 1

<https://youtu.be/5JkQyL6VJM4>

In 1 revolution of beige input shaft the blue output shaft turns 120 deg. then pauses.

Yellow and cyan disks keep the output immobile during dwell time.

The input has 4 teeth.

The output has 18 teeth.

Top of the end teeth of the beige gear have been cut off a little to get gear proper engagement.

The mechanism can work with any rotary direction.

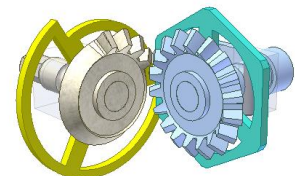

Bevel gears for interrupted rotation 2

<https://youtu.be/OmyPyuWajvc>

In 1 revolution of grey input shaft, the blue output shaft turns 90 deg. then pauses.

Yellow and cyan disks keep the output immobile during dwell time.

The input has 3 teeth.

The output has 20 teeth.

The mechanism can work with any rotary direction.

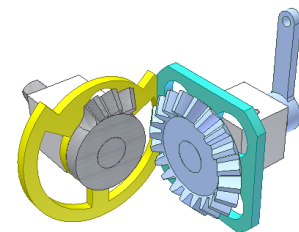

Indexing mechanism 4 (90 deg.)

<https://youtu.be/YziLxHpaBFA>

Input: beige face gear (tooth-uncompleted) rotating continuously.
Output: green gear (tooth-uncompleted) that performs interrupted rotation. In 1 input revolution it quickly turns 90 deg. (with the support of the flat spring) and dwells (thanks to flat (no teeth) section of the beige face gear).

The original green gear (tooth-completed) has 16 teeth.

Increase the beige gear diameter for a larger dwell/motion time ratio of the output.

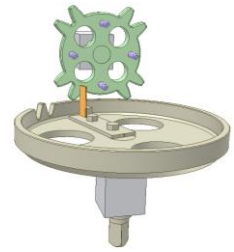

Indexing mechanism 5 (180 deg.)

<https://youtu.be/DwPyMDDs2iQ>

Input: blue face gear (tooth-uncompleted) rotating continuously.
Output: green gear (tooth-uncompleted) that performs interrupted rotation. In 1 input revolution it quickly turns 180 deg. (with the support of the flat spring) and dwells (thanks to flat (no teeth) section of the blue face gear).

The original green gear (tooth-completed) has 10 teeth.

Increase the blue gear diameter for a larger dwell/motion time ratio of the output.



Transmission with teeth-uncompleted gears 24

<https://youtu.be/asi4CzSWvBo>

Input: blue face gear (tooth-uncompleted) rotating continuously.
Output: green gear (tooth-uncompleted) that performs interrupted rotation. In 1 input revolution it turns 360 deg. (with the support of the flat spring) and dwells (thanks to flat (no teeth) section of the blue face gear).
The original green gear (tooth-completed) has 10 teeth.
Increase the blue gear diameter for a larger dwell/motion time ratio of the output.



Interrupted rotation of satellite gear 2

<https://youtu.be/jtKbQlif82c>

Input: blue crank rotating continuously.

Output: green satellite gear that performs interrupted rotation. In 1 input revolution it quickly turns 90 deg. (with the support of the flat spring) and keeps that direction until the next flip (thanks to flat (no teeth) section of the grey face gear).

The original green gear (tooth-completed) has 16 teeth.

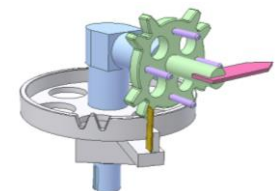

Interrupted rotation of satellite gear 1

<https://youtu.be/sfCntlZeEDA>

Input: blue crank rotating continuously.

Output: green satellite gear that performs interrupted rotation. In 1 input revolution it quickly flips 180 deg. (with the support of the flat spring) and keeps that direction until the next flip (thanks to flat (no teeth) section of the grey face gear).

The original green gear (tooth-completed) has 10 teeth.

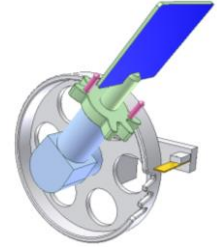

Drive for car movable trivision billboards

<https://youtu.be/R9H-y1QDdbA>

The bendable billboards are attached to two parallel tooth belts and the brown motor moves them periodically. The billboards are displayed on three surfaces of the car (side and back).

In 1 rev. of yellow shaft each tooth belt moves a half of its length. So on each car surface two different posters can be displayed alternately. Tooth uncompleted gear is used for creating interrupted rotation.

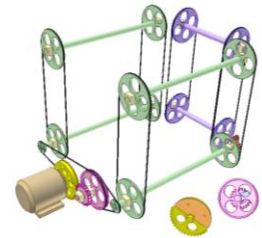

Successive 360 deg. rotation 2

<https://youtu.be/MMbCGqT3o4I>

Input: pink block of three tooth-uncompleted gears.

For the pink gears:

- number of teeth (tooth-completed): 54
- number of remained teeth: 17

Angular offset between three gears is 120 deg.

Output: 3 gear cam blocks rotates 360 deg. successively in one revolution of the input.

The small gears are kept immobile during their pause stages thanks to no teeth sector of the pink gears. This way requires precise manufacture and is not good for high speed.

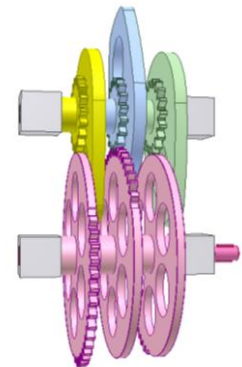

Tooth-uncompleted gear for intermittent 120 deg. rotation

<https://youtu.be/PbAbSMEUUGI>

Input: large gear (tooth-uncompleted), rotating continuously.

Its number of teeth (teeth-completed) 36

Its number of remained teeth $5 \cdot 3 = 15$

Tops of two end teeth of each tooth section are cut off for meshing start.

Output: small gear rotating interruptedly.

Its number of teeth 18

In 1 revolution of the input, the output turns 120 deg. and pauses for 3 times.

The small gear is kept immobile during its pause stages thanks to no teeth sector of the large gear.

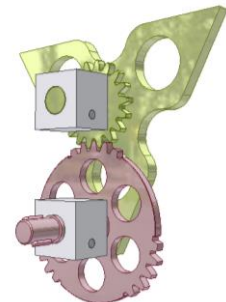

2.2. Geneva drives

Geneva mechanism 1

<http://www.youtube.com/watch?v=vEU5cXwiykQ>

The ratio of motion period to dwell period is 1/5.
Angle of each rotation of the driven shaft is 120 degrees.

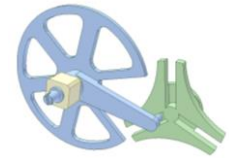

Geneva mechanism 2

http://www.youtube.com/watch?v=GbEJFDP8f_E

Angle between the three pins is 120 degrees.
During 1 revolution of the driving shaft the driven disk has 3 dwell times and 3 motion times alternately.
Angle of each rotation of the driven shaft is 120 degrees.

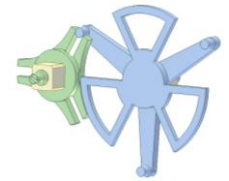

Geneva mechanism 3

http://www.youtube.com/watch?v=qFd-Kt_vTDs

Angle between the two pins is 120 degrees.
During 1 revolution of the driving shaft the driven disk has 2 dwell times and 2 motion times alternately. Dwell periods of the two dwell times are different.
Angle of each rotation of the driven shaft is 120 degrees.



Geneva mechanism 4

http://www.youtube.com/watch?v=TErAWmR66_s

The ratio of motion period to dwell period is 1/3.
Angle of each rotation of the driven shaft is 90 degrees.



Geneva mechanism 5

<http://www.youtube.com/watch?v=BM5fLiOxM3o>

Angle between the two pins is 180 degrees.
During 1 revolution of the driving shaft the driven disk has 2 dwell times and 2 motion times alternately.
Angle of each rotation of the driven shaft is 90 degrees.

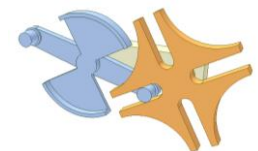

Geneva mechanism 6

<http://www.youtube.com/watch?v=NjlfzPXpds>

Angle between the two pins is 120 degrees, not a multiple of 90.
Angle of each rotation of the driven shaft is 90 degrees.



Geneva mechanism 7

<http://www.youtube.com/watch?v=uhEvxBxFoXA>

The ratio of motion period to dwell period is 1/5.
Angle of each rotation of the driven shaft is 60 degrees.



Geneva mechanism 8

<http://www.youtube.com/watch?v=3Ju7N-VM7Qw>

The disks rotate and pause one after another.
The ratio of motion period to dwell period is 1/5.
Angle of each rotation of the disks is 120 degrees.



Geneva mechanism 9

<http://www.youtube.com/watch?v=RF5JN2dHMMA>

The disk interruptedly rotates 70 and 50 degrees.

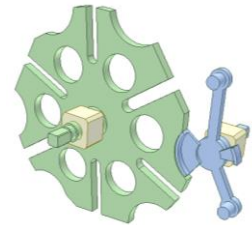

Geneva mechanism 10

<http://www.youtube.com/watch?v=BuuVSIchqZU>

By applying skew slots the ratio of motion period to dwell period is 1/5, not 1/3 like in standard 4-slot Geneva mechanism:

http://www.youtube.com/watch?v=TErAWmR66_s

Angle of each rotation of the driven shaft is 90 degrees.

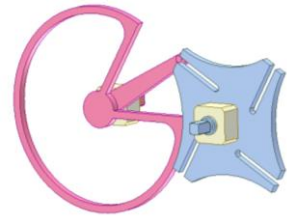

Geneva mechanism 11

http://www.youtube.com/watch?v=845_WfUmSI0

By applying skew slots the ratio of motion period to dwell period is 1/5, not 2/5 like in standard 10-slot Geneva mechanism.

Angle of each rotation of the driven shaft is 36 degrees.

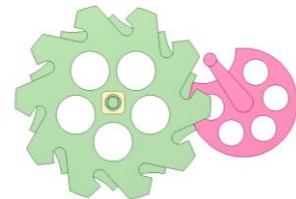

Geneva mechanism 12

<http://www.youtube.com/watch?v=pPhjq5IHVyY>

Twin Geneva mechanism. The green disk interruptedly rotates 60 degrees with different dwell periods.

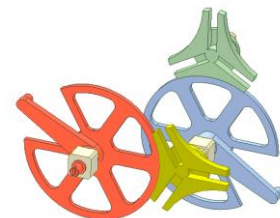

Geneva mechanism 13

<http://www.youtube.com/watch?v=PoJBG5mR2c>

Twin Geneva mechanism. The green disk interruptedly rotates 120 degrees. The ratio of dwell period to motion period is 8/1.



Successive 90 deg. rotation 2b

<https://youtu.be/PGfp3SZOXZs>

It is an application of four Geneva drives shown at:

http://www.youtube.com/watch?v=TErAWmR66_s

Input: outside pink crank.

The rotation is transmitted to the end crank (in blue) via a gear train of zigzag shape. This transmission enables square frames (in glass) to be fixed to grey Geneva disks.

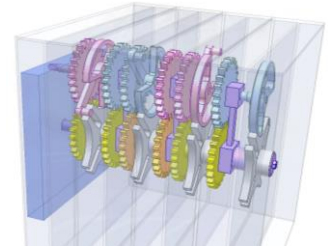

Chain drive 3D

http://youtu.be/1_yyZ93JJA

The violet sprocket is driving.

Dwell time of the output Geneva disk depends on the number of the chain links.

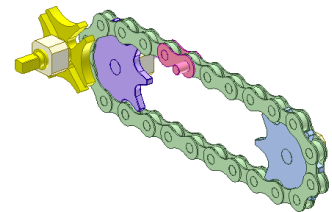

Geneva mechanism 14

http://youtu.be/_TmvoXFxyNw

Input: blue crank

Output: green disk rotating with dwells.

Input and output are coaxial.

In one revolution of the blue crank the green disk rotates $\frac{1}{4}$ rev.

Red curve is locus of the red roller center.

Orange slider kept the green disk immobile during its dwell.

Main dimensions of the mechanism are:

- crank radius of the blue crank
- side length of the green square disk
- length of the pink conrod.

They are determined based on a sketch (not shown) where:

- Angle of crank and horizontal line is 60 deg.
- Angle of square side of the green disk and horizontal line is 45 deg.
- Square side (contains roller center), crank radius line and the line that is drawn from the slider center and perpendicular to the sliding direction of the runway, are concurrent.

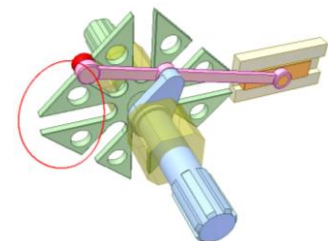

Geneva mechanism 15

<http://youtu.be/TYRks3vmAll>

Input: pink crank

Output: green disk rotating with dwells.

Yellow cam (fixed to the crank) and blue lever with its pins keep the green disk immobile during dwells.

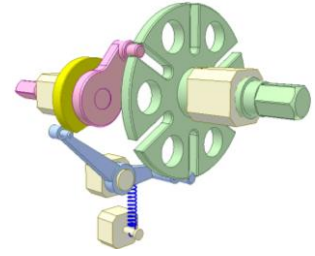

Geneva mechanism 16a

<http://youtu.be/rI9VJuzrNVg>

Input: green crank

Output: orange disk rotating with dwells.

Pink slider has pins that slide in grooves of the green crank and the orange disk.

Fixed popcorn disk cam and the pink slider help to reduce acceleration of the orange disk.

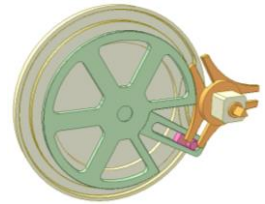

Geneva mechanism 16b

<http://youtu.be/rhObov9nyVQ>

Input: green crank carrying orange slider

Output: pink disk rotating with dwells.

The slider has pins that slide in grooves of the pink disk and of fixed yellow guide plate. The latter and the orange slider help to reduce acceleration of the pink disk.

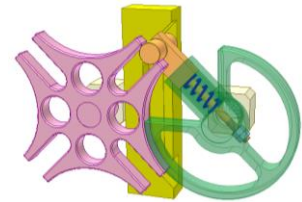

Geneva mechanism 19

<http://youtu.be/LkYHh29c16A>

Input: pink crank

Output: green disk rotating with dwells.

A four bar linkage makes angular speed of the output more regular.

Blue curve is locus of pin center of the blue V-shaped bar.

Measure to keep the green disk immobile during its dwells is not shown.

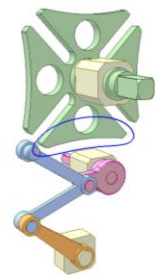

Geneva mechanism 20

<http://youtu.be/CsEaqHMsXEA>

Input: pink crank

Output: green disk oscillating with dwells at both stroke ends.

Adjust positions of orange slider and yellow plate to get various motion rules of the output.

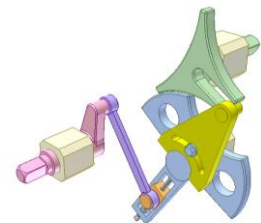

External Geneva and epicyclic gear mechanism 1

<https://youtu.be/N5rZRxOqNwI>

Input: blue crank.

Output: green disk

The pin that interacts with the disk slots is placed on the satellite pinion (in pink). Its center traces a square (in pink). For other curves see:

<https://youtu.be/XDZAvCDoMhg>

$$Z_g/Z_p = 2n/(n-2)$$

$$R + r = B \cdot \sin(\pi/n)$$

Z_g : tooth number of the stationary grey gear.

Z_p : tooth number of the pink gear.

N : number of slots on the green disk, Here $n = 4$

R : distance from axis of the pink gear to rotary axis of the blue crank.

r : radius of the pink crank.

B : distance between two stationary bearings.

Blue ring is for keeping the green disk immobile during its dwell.

The output acceleration is reduced considerably in this mechanism in comparison with ordinary Geneva one.

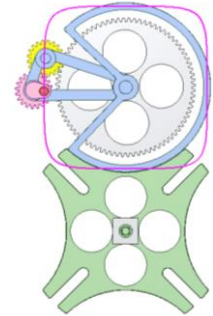

Geneva mechanism 20

http://youtu.be/vu6_WfDXUIQ

Input: blue crank with locking disk carrying green planet gear.

Output: orange disk rotating interruptedly.

Two gears have same tooth number. Blue crank radius is equal to gear pitch one.

The motion period of the output is decreased over ordinary Geneva mechanism.

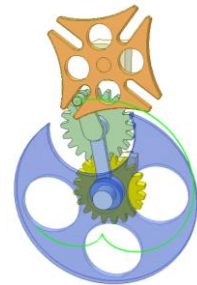

Loci in Epicyclic gearing A4m

<http://youtu.be/B3eA9WydI24>

R : pitch diameter of the fixed sun gear

r : pitch diameter of the planetary gear

$$k = R/r = 4$$

Distance between the pin axis and the gear axis of the planetary gear is $(11/30)r$ to get a square locus of straight side for the center of the pin.

This produces a smoother indexing motion of the orange Geneva disk rotates because the driving pin moves on a noncircular path, unlike in standard Geneva mechanism.

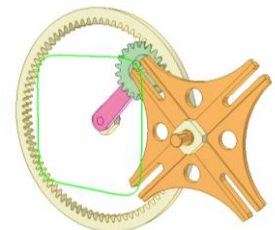

Loci in Epicyclic gearing A4mb

<http://youtu.be/t0243w69178>

R: pitch diameter of the fixed sun gear

r: pitch diameter of the planetary gear

$$k = R/r = 4$$

Distance between the pin axis and the gear axis of the planetary gear is $(5/3)r$ to get an appropriate loop locus for the center of the pin.

This produces a smoother indexing motion of the orange Geneva disk because the driving pin moves on a nearly circular curve, center of which is the rotation center of the Geneva disk.

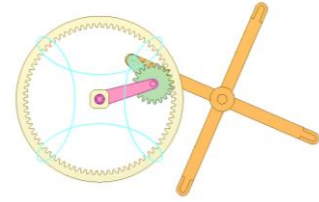

Geneva mechanism 22

<http://youtu.be/QkzRb7b36IY>

Input: pink crank.

Output: yellow Geneva disk oscillating with dwell at its stroke middle.

Output motion rule can be adjusted by setting positions of violet or green roller bars and grey conrod on blue disk.

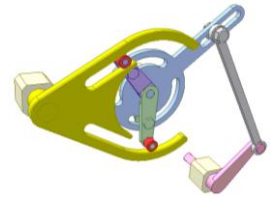

Geneva mechanism 21

<http://youtu.be/HuJSoUqIKws>

Input: yellow disk of orange pin rotating continuously.

Output: blue disk rotating interruptedly.

1 rev. of the input makes the output rotate 90 deg.

Other than standard Geneva mechanism it uses four cyan pins on the blue disk and circular groove of the yellow disk to keep the blue disk immobile during its dwells.

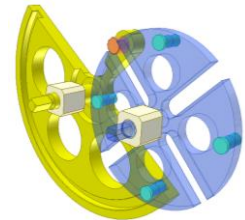

Geneva mechanism 17

<http://youtu.be/J7-lAwdrEkw>

Input: pink crank

Output: green disk rotating with dwells.

In one revolution of the pink crank the green disk rotates 180 deg., a thing that ordinary Geneva mechanisms can not get.

Orange sliders prevent reverse rotation of the green disk when yellow roller of the pink crank reaches corners of the disk grooves.

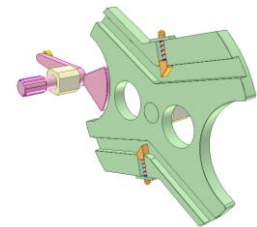

Geneva mechanism 18

<http://youtu.be/uNVF-EZ6myA>

Input: orange crank carrying an ellipsed-shape pin.

Output: green disk rotating with dwells.

I have tried to find out what is the advantage of this Geneva mechanism but no success. Unexpected result: its output acceleration is even larger than in ordinary Geneva mechanism.

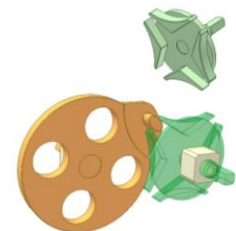

Geneva mechanism 23a

https://youtu.be/ucDi35_oUpQ

Input: regularly rotating pink crank to which pink disk is fixed.

Output: interruptedly rotating blue disk to which green disk is fixed.

1 revolution of the input makes the output turn 60 deg.

The crank enters the V-slots at their right strokes.

Pink and green disks are for keeping the output immobile during its dwells.

In comparison with an ordinary Geneva of 6 slots the time for turning the output 60 deg. is shorter.

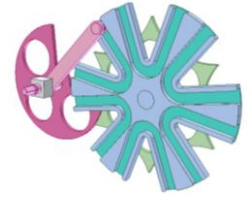

Geneva mechanism 23b

<https://youtu.be/WaqEA1dGiKM>

Input: regularly rotating pink crank to which pink disk is fixed.

Output: interruptedly rotating blue disk to which green disk is fixed.

1 revolution of the output corresponds 4 revolutions of the input.

Unusual thing: the output turns 50 deg., stops, turns 130 deg., stops and the process repeats although the blue disk is of symmetrical structure. V-groove angle: 40 deg.

The crank enters the V-grooves now at their right strokes, now at their left ones.

Pink and green disks are for keeping the output immobile during its dwells.

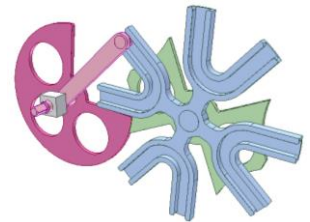

Geneva mechanism 24

https://youtu.be/2ttLn_XO_00

Input: blue gear of Z1 teeth carrying blue lever of two pins. It rotates counterclockwise.

Output: pink Geneva disk.

Green gear of Z2 teeth has two pins. $Z1 = 2 \cdot Z2$

In 1 rev. of the green gear the Geneva disk performs 120 deg. angular reciprocating motion.

Counterclockwise turning time is double of clockwise one.

Slow forward motion, quick backward motion

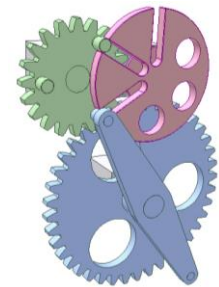

Geneva mechanism 25

<https://youtu.be/FOf2538KtyY>

Input: pink disk of two slots and two violet pins. It rotates continuously.

Output: blue cross of four cyan pins.

Yellow cross is mounted idly on the blue cross.

Red spiral spring tends to turn the yellow cross clockwise. Small blue pin acts as a stopper for the yellow cross. The spring forces the cyan pins to enter the disk slots.

In one revolution of the input, the output turns 90 deg. and pauses two times.

The mechanism shown at

<https://youtu.be/BM5fLiOxM3o>

has the same feature but its output acceleration is larger.

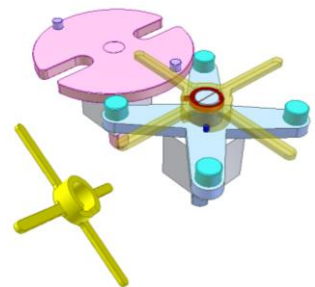

Internal Geneva mechanism 1

<http://www.youtube.com/watch?v=n8xLpbwsTcg>

The ratio of dwell period to motion period is 1/2.

Angle of each rotation of the driven shaft is 120 degrees.

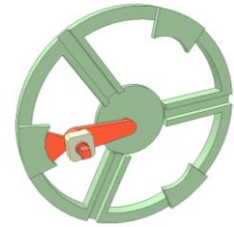

Internal Geneva mechanism 2

<http://www.youtube.com/watch?v=ReXprJUMqF4>

The ratio of dwell period to motion period is 1/3.

Angle of each rotation of the driven shaft is 90 degrees.

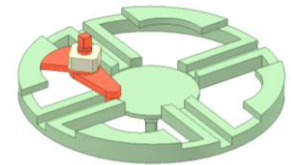

Internal Geneva mechanism 2b

<https://youtu.be/4Mu75T1cDcs>

Input: brown gear rotating continuously.

Output: green disk. Ratio of dwell period to motion period is 1/3.

Angle of each rotation of the disk is 90 degrees.

Input and output are coaxial.



Internal Geneva mechanism 3

<http://www.youtube.com/watch?v=MQP7yNxx3ag>

The ratio of dwell period to motion period is 1/5.

Angle of each rotation of the driven shaft is 60 degrees.

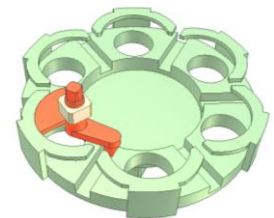

Internal Geneva mechanism 4

http://www.youtube.com/watch?v=w1oT0Zx_xcU

The ratio of dwell period to motion period is 1/3.

Angle of each rotation of the driven shaft is 90 degrees.

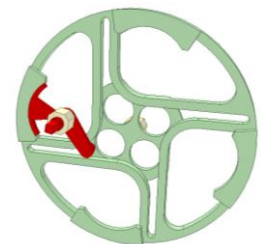

Internal Geneva and epicyclic gear mechanism 1

<https://youtu.be/xVPMGday3GE>

Input: blue crank.

Output: green disk

The pin that interacts with the disk slots is placed on the satellite pinion (in pink). Its center traces yellow line.

$$Z_g/Z_p = 2n/(n-2)$$

$$R + r = B \cdot \sin(\pi/n)$$

Z_g: tooth number of stationary grey gear. Here Z_g = 80.

Z_p: tooth number of pink gear. Here Z_p = 20.

n: number of slots on green disk, Here n = 4

R: distance from axis of the pink gear to rotary axis of the blue crank.

r: radius of the pink crank.

B: distance between two stationary bearings.

Blue ring is for keeping the green disk immobile during its dwell.

The output acceleration is reduced considerably in this mechanism in comparison with ordinary Geneva one.

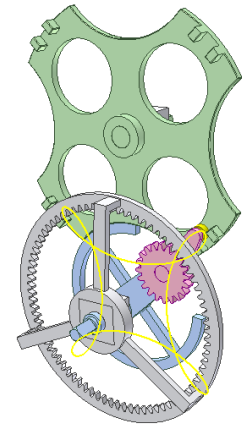

Trivision Billboard with Geneva mechanism

<http://www.youtube.com/watch?v=uCx9riKxTvY>

Meslab is the name of the Vietnamese forum of Materials, Mechanical, Automation and Industrial Engineering.



Internal Geneva mechanism 5

<https://youtu.be/qtKoDmKGr64>

Input: pink crank.

Output: yellow shaft of Geneva disk.

Angle of each rotation of the driven shaft is 90 degrees.

The ratio of dwell period to motion period of the output is K = 1/1.

In conventional internal Geneva drive K = 1/3

<http://www.youtube.com/watch?v=ReXprJUMqF4>

Violet sector and orange disk are for keeping the output immobile when red roller does not contact the Geneva disk.

Green curve is locus of the roller center.

This video was made based on:

<https://www.youtube.com/watch?v=0RRnEx3CRs8>

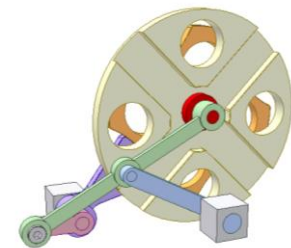

Star wheel drive 4

<http://youtu.be/TaZKjLB-KVU>

An invention of Martin Zugel of Cleveland, Ohio, USA.

Input: green disk of two pink pins.

Output: yellow disk rotating interruptedly.

In one revolution of the input, the output turns 90 deg.

Motion time is around 20% cycle time (25% cycle time for a standard Geneva one).

Inertia load is less than in a standard Geneva drive.

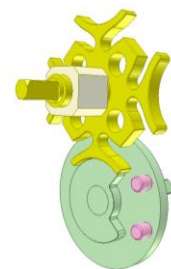

Star wheel drive 3

<http://youtu.be/gFECTmIUtMM>

An invention of Martin Zugel of Cleveland, Ohio, USA.

Input: green disk of two pink pins.

Output: yellow disk rotating interruptedly.

In one revolution of the input, the output turns 120 deg.

Motion time is around 40% cycle time (16.7% cycle time for a standard Geneva one).

Inertia load is less than in a standard Geneva drive.

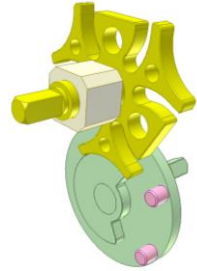

Star wheel drive 1

http://youtu.be/9hG_dL40M6Y

An invention of Martin Zugel of Cleveland, Ohio, USA.

Input: green disk of two pink pins.

Output: orange disk rotating interruptedly.

The input and output are not coaxial.

In one revolution of the input, the output turns 360 deg.

This operation is not possible with standard Geneva drives.

Motion time is around 40% cycle time.

Dark green rim keeps the output disk immobile during its dwell.

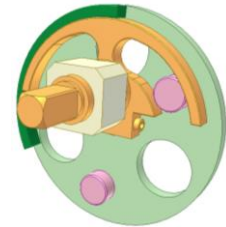

Spatial Geneva mechanism 1

<http://www.youtube.com/watch?v=rqDfalBVhIU>

The ratio of dwell period to motion period is 1/1.

Angle of each rotation of the driven shaft is 120 degrees.

Angle between the pin axis and the crank axis is 60 degrees.

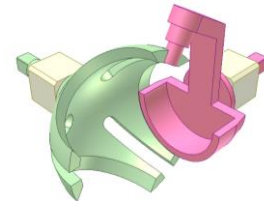

Spatial Geneva mechanism 2

<http://www.youtube.com/watch?v=IUv4TaxKyuw>

The ratio of dwell period to motion period is 1/1.

Angle of each rotation of the driven shaft is 90 degrees.

Angle between the pin axis and the crank axis is 45 degrees.



Spatial Geneva mechanism 3

http://www.youtube.com/watch?v=cKi_Hlp9rA8

The ratio of dwell period to motion period is 1/1.

Angle of each rotation of the driven shaft is 60 degrees.

Angle between the pin axis and the crank axis is 30 degrees.



Spatial Geneva mechanism 4

<http://www.youtube.com/watch?v=-M3BIExZAYs>

The ratio of dwell period to motion period is 1/1.

Angle of each rotation of the driven shaft is 20 degrees.

Angle between the pin axis and the crank axis is 10 degrees.



Spatial Geneva mechanism 5a

<http://youtu.be/a-l3VCDKuvs>

Input: blue crank with locking ring.

Output: yellow cylinder with orange locking disk rotating interruptedly.

Ellipse section of the blue crank pin is for easy designing the mechanism. Round section is possible.

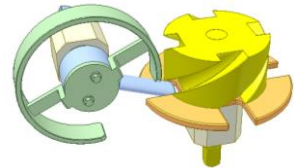

Spatial Geneva mechanism 5b

<http://youtu.be/2vB68uod2Bc>

Input: blue crank with locking ring.

Output: yellow cylinder with orange locking disk.

Ellipse section of the blue crank pin is for easy designing the mechanism. Round section is possible.

The mechanism performs 180 deg. indexing that is impossible for ordinary Geneva mechanisms.

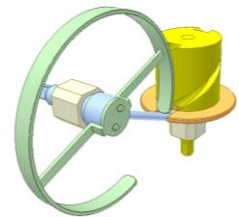

2.3. Ratchet drives

Ratchet mechanism 1

<http://www.youtube.com/watch?v=eijyLC4ZzQk>

A device directly converts the continuous rotary motion of a drive shaft into the intermittent rotary motion of a driven shaft.

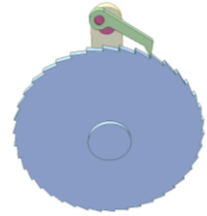

Ratchet mechanism 2

<http://youtu.be/V4yxGR4d7I8>

This mechanism directly converts the continuous rotary motion of a drive shaft into the intermittent rotary motion of a driven shaft.

By flipping the blue pawl the motion direction of the driven shaft can be changed without changing the input motion direction.

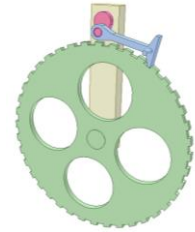

Two way ratchet mechanism 1

<https://youtu.be/4A78AyRVbQ8>

Turn violet lever 45 deg. and release it to make pink ratchet wheel turn 45 deg. Repeat the process for another 45 deg. The motion can be performed in either direction.

The yellow screws act as stoppers for 45 deg. rotation of the lever. Two red identical springs bring the released lever to its neutral position.

Two brass identical leaf springs force pawls (in blue and green) towards the ratchet wheel and the yellow cover.

When the lever is released, the ratchet wheel is kept immobile thanks to spring pin and cone holes on the wheel.

The mechanism can be applied for gear shifting in motorcycles.

To get stable neutral position of the lever refer to:

<https://youtu.be/Zq5ursxPGPg>

<https://youtu.be/8U76DPUmG8o>

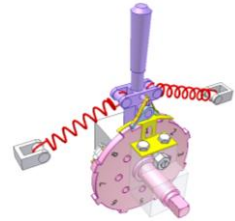

Sheet metal ratchet drive 1

<http://youtu.be/qT3S7sOhYS8>

For light loads.

Low cost.

Adaptability to mass production.

Permanent contact between pawl and ratchet wheel is maintained by pawl's weight.

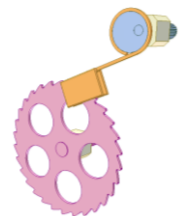

Sheet metal ratchet drive 2

<http://youtu.be/miDCNBMLR3E>

For light loads.

Low cost.

Adaptability to mass production.

Permanent contact between pawl and ratchet wheel is maintained by pawl's weight.



Ratchet mechanism 3

<http://youtu.be/WeV89YavvO8>

To adjust position of the pink cover for getting various rotation angle of the green wheel.

To pull the orange pawl and rotate it 180 degrees to change rotation direction of the green wheel.

This mechanism is used in shapers.

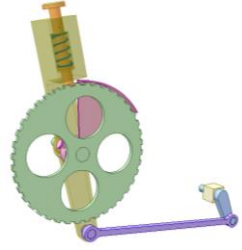

Ratchet mechanism 4

<http://youtu.be/vW6PuvfIUrM>

The ratchet wheel has internal teeth.

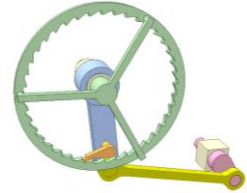

Ratchet mechanism 5

http://youtu.be/bAL_nWjuhOI

Bicycle free-wheel.

The blue sprocket receives motion from the pedaling bicyclist. The yellow hub rotates only when the sprocket rotates clockwise.

Clockwise rotation of the yellow hub has no influence to the blue sprocket.

The red pawl is always pressed toward the sprocket's teeth by a spring. In reality two pawls are used.

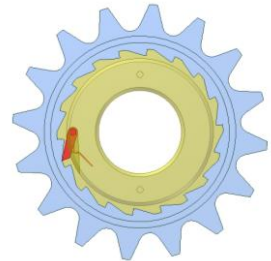

Ratchet mechanism 8

<http://youtu.be/4wQkKdf9ReU>

The input green disk through the blue pawl makes the output ratchet wheel rotate interruptedly. The pink and yellow pins control pause time of the ratchet wheel. Each pin makes the ratchet wheel pause for 1/8 revolution of the input disk.

The blue pawl is always pressed toward the sprocket's teeth by a spring (not shown).

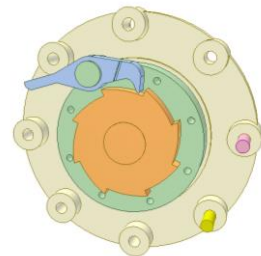

Ratchet mechanism for 360 deg. rotation

<https://youtu.be/nPXjauQj3AQ>

Input: orange ratchet wheel.

Output: green shaft carrying pink pawl.

Push and release blue lever to let the green shaft rotate 360 deg.

A flat spring forces the pawl toward the ratchet wheel.

Another flat spring returns the blue lever to its initial position.

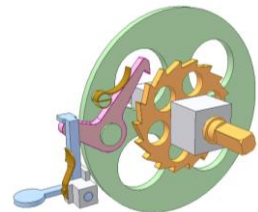

Ratchet mechanism 9

http://youtu.be/_wqPI2ms2kk

There are two pawls. The pink pushes the ratchet wheel. The green keeps the wheel immobile when the pink reverses.

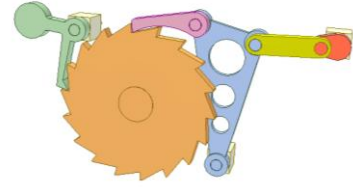

Ratchet mechanism 12

<http://youtu.be/tvByEbHmcfc>

There are two pawls. The green pushes the pink gear and is not always in contact with it (unlike ordinary ratchet mechanism). The blue keeps the wheel immobile when the green does not push the gear.

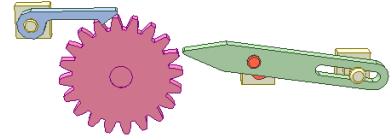

Ratchet mechanism of pin gear 1

<http://youtu.be/ISQQZAvi7H0>

Input: pink crank rotating continuously.

Output: yellow pin gear.

Gravity maintains contact between blue pawl and pin gear.

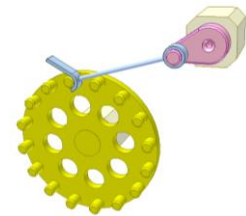

Ratchet mechanism 13

<http://youtu.be/r-2Xe3moMPs>

The input yellow disk through the orange pawl makes the output green ratchet wheel rotate interruptedly. The length of the blue cam regulates moving time of the wheel.

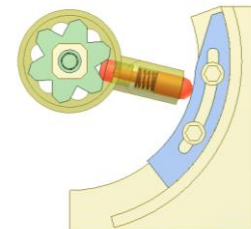

Ratchet mechanism 15

http://youtu.be/_k7JzvFq88g

There are two pawls. The pink pushes the ratchet wheel. The green keeps the wheel immobile when the pink reverses. The yellow slotted cam is the input.

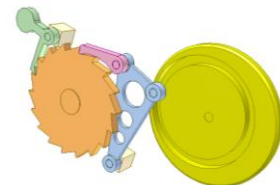

Ratchet mechanism 16

<http://youtu.be/5l74rKEJlp0>

Input is pink crank of constant velocity.

Green rocker (ratchet wheel of internal teeth) turns an angle of around three teeth in each revolution of the crank. But the yellow disk rotates at different angles because of its eccentrical rotary axis.

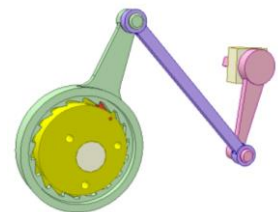

Ratchet mechanism 31

<http://youtu.be/sSVz1cMMYIY>

Input: green crank oscillating.

Output: ratchet wheel rotating interruptedly.

Blue spring maintains contact between yellow pawl and ratchet wheel.

Speciality: internal tooth wheel, external pawl.

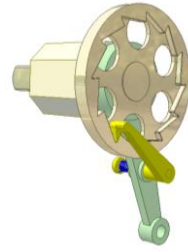

Ratchet mechanism 17

<http://youtu.be/GuM-WgaQnc8>

Input: green eccentric shaft.

Output: grey ratchet wheel.

Gravity maintains contact between pawl and ratchet wheel.



Ratchet mechanism 27

http://youtu.be/_vWezNG0I8g

Grey solenoid makes blue rod reciprocate.

The unusualness is: orange pawl has prismatic joint with the blue driving rod, not revolution one as ordinary pawls.

Flat spring maintains the contact between pawl and yellow wheel.

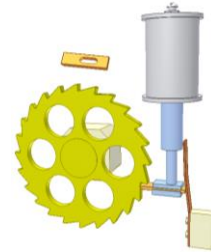

Cable drive for 180 deg. rotation

<http://youtu.be/VzBulhyWsJY>

Pull and release brown tow to let yellow ratchet disk turn 180 deg. One end of the tow is fixed to blue disk. Orange leaf spring keeps the yellow ratchet disk immobile during its dwell. A circular slot on the blue disk and a pin on the case limit oscillating angle of the blue disk. A coil spring (not shown) makes the blue disk turn back when the tow is released.

Replacement of cable drive with rack-pinion one is possible.

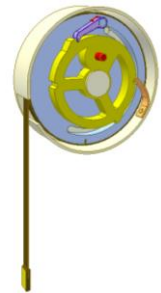

Ratchet mechanism 18

<http://youtu.be/urvRRQQMd9Y>

Input: blue crank.

Output: pink ratchet wheel.

Both go and back motions of the blue crank make the wheel rotate in the same direction. The pawls push the wheel.

Gravity maintains contact between pawls and ratchet wheel.

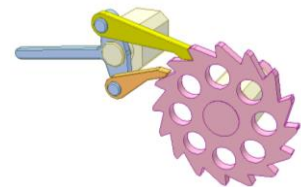

Ratchet mechanism 19

<http://youtu.be/RYrn5XjDTg4>

Input: green crank.

Output: ratchet wheel.

Both go and back motions of the green crank make the wheel rotate in the same direction. The pawls pull the wheel.

Gravity maintains contact between pawls and ratchet wheel.

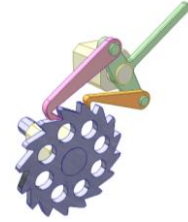

Ratchet mechanism 20

<http://youtu.be/tZfwSkw8uGM>

Input: green crank.

Output: blue ratchet wheel.

Both go and back motions of the crank make the wheel rotate in the same direction. Yellow pawl pushes and orange pawl pulls the wheel.

Violet springs maintain contact between pawls and ratchet wheel.

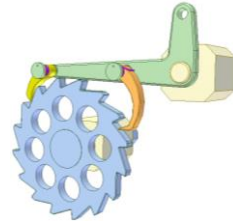

Ratchet mechanism 21

<http://youtu.be/JZt-L8xFLyU>

Input: pink crank.

Output: yellow ratchet wheel that can rotate interruptedly in both direction.

Blue rocker oscillates thanks to four bar mechanism.

Red springs maintain contact between pawls and ratchet wheel.

Use grey sector to prevent contact between the wheel and one of the pawls for changing rotary direction of the output.

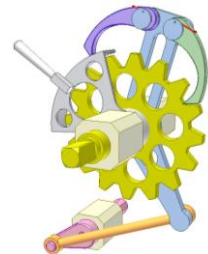

Ratchet mechanism 22

<http://youtu.be/4wMIWhI2DhE>

Input: pink crank.

Output: green ratchet wheel.

Both go and back motions of blue slider make the wheel rotate in the same direction. Orange pawl pushes and yellow pawl pulls the wheel.

Spring maintains contact between pawls and ratchet wheel.



Ratchet mechanism 23

<http://youtu.be/ifjCLOztQZM>

Input: green crank oscillating.

Output: blue ratchet wheel.

Both go and back motions of oscillating green crank make the wheel rotate in the same direction.

Yellow pawl pushes and orange pawl pulls the wheel.

Gravity maintains contact between pawls and wheel.

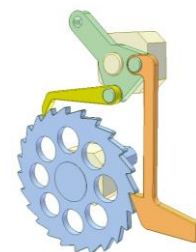

Ratchet mechanism 24

<http://youtu.be/37kxWCIRLO4>

Input: green crank oscillating.

Output: ratchet wheel.

Both go and back motions of oscillating green crank make the wheel rotate in the same direction.

The pawls push the wheel.

Spring maintains contact between pawls and ratchet wheel.

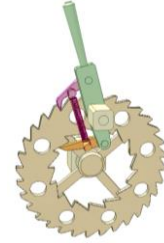

Ratchet mechanism of pin gear 2

<http://youtu.be/PSMWGHKGu5k>

Input: green crank .

Output: yellow pin gear.

Both go and back motions of the green crank make the gear rotate in the same direction. The grey bars push the gear.

Gravity maintains contact between pawls and pin gear

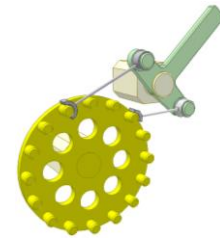

Ratchet mechanism 25

<http://youtu.be/gzLSJ-6qvWA>

Input: green oscillating crank.

Output: yellow ratchet wheel.

Blue ratchet wheel is idly mounted on violet fixed shaft.

Red spring creates friction between the blue ratchet wheel and fixed violet shaft thus prevents the blue wheel from reverse rotation.

Pink pawl makes the blue ratchet wheel rotate.

Orange pawl makes the yellow ratchet wheel rotate.

Red sector of the blue ratchet wheel periodically prevents contact between the orange pawl and the yellow wheel thus the latter rotates interruptedly with different dwell times.

Gravity maintains contact between pawls and wheels.

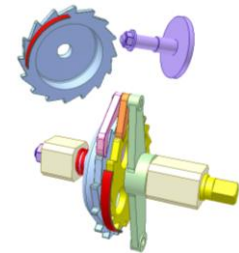

Ratchet mechanism 26

<http://youtu.be/UFU1NkXvCJo>

Input: blue cam.

Output: pink ratchet wheel rotating interruptedly with long dwells.

Both go and back motions of yellow oscillating pawl make the wheel rotate in the same direction (one tooth).

The pawl keeps the ratchet wheel immobile during its dwells.

Red spring maintains contact between the pawl and the cam.

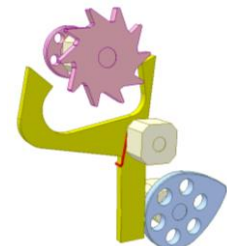

Ratchet mechanism 32

<http://youtu.be/uwgs1twBa7g>

Input: green crank oscillating.

Output: ratchet wheel of tooth number Z rotating interruptedly.

The gravity maintains contact between 2 coaxial pawls and ratchet wheel.

The ratchet wheel thickness must be twice the pawl ones.

Speciality: the mechanism acts as in case where there is one pawl and ratchet wheel tooth number is $2Z$. It helps increase tooth strength.

The pawls one by one push the wheel.

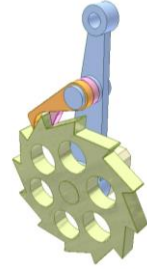

Ratchet mechanism 33

<http://youtu.be/ZeAYihlABSw>

Input: green crank oscillating.

Output: ratchet wheel of tooth number Z rotating interruptedly.

The gravity maintains contact between 3 identical pawls and ratchet wheel.

Speciality: the mechanism acts as in case where there is one pawl and ratchet wheel tooth number is $3Z$. It helps increase tooth strength.

The pawls one by one push the wheel.



Ratchet mechanism 35

<http://youtu.be/3e6axpv1SsY>

Input: grey crank oscillating.

Output: violet slider that linearly moves interruptedly.

Tooth number of green wheel $Z_g = 12$.

Tooth number of yellow wheel $Z_y = 11$.

Blue pawl contacts the green wheel.

Orange pawl contacts the yellow wheel.

The green wheel has helical joint with pink screw.

The yellow wheel has prismatic joint with pink screw.

The gravity maintains contact between the wheels and the pawls.

The screw pitch is P mm.

12 double strokes of the input crank make the green wheel turn 1 revolution and the yellow wheel turn $1 + 1/11$ revolutions. Thus the screw turns $1/11$ rev. in relation with the green wheel (nut) and the slider moves $P/11$ mm (small displacement).

The video also shows case when the orange pawl does not engage with the yellow wheel.

The latter is immobile so the screw can not rotate. 12 double strokes of the input crank make the green wheel turn 1 revolution and the slider moves P mm (large displacement) in the opposite direction (in the same direction if $Z_g = 11$, $Z_y = 12$).

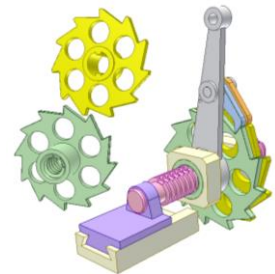

Ratchet mechanism for anti-reverse 1

<http://youtu.be/rKYTr9NjgOA>

Green ratchet wheel rotates only anticlockwise.

The reverse rotation is prevented by yellow flat spring.

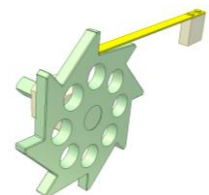

Ratchet mechanism for anti-reverse 2

<http://youtu.be/g4vFJtps-Q>

Yellow ratchet wheel rotates only anticlockwise.
The reverse rotation is prevented by blue slider.

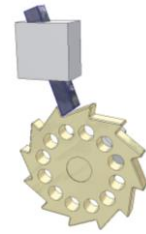

Ratchet mechanism for anti-reverse 3

<http://youtu.be/14i2UWR87ik>

Yellow face tooth ratchet wheel rotates only clockwise.
The reverse rotation is prevented by pink pawl.



Friction ratchet mechanism 1

<http://youtu.be/JWLXmY0QzP8>

The yellow cam plays pawl's role. The friction force between the yellow cam and the green no-teeth wheel drives the latter.
No noise and backlash in comparison with ordinary ratchet mechanisms

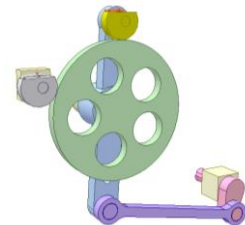

Friction ratchet mechanism 2

<http://youtu.be/aCN-HEBsdYM>

Input: orange oscillating drum.

Output: yellow shaft rotating interruptedly.

Four flat springs allow motion transmission only in anticlockwise direction.

The mechanism is for light duty works and where the kinematic relation between the input and output is not required strictly.

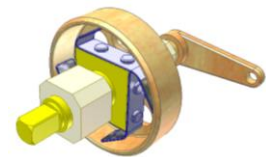

Friction ratchet mechanism 3

<http://youtu.be/M-3eLefY3fw>

Input: blue oscillating lever.

Output: yellow shaft rotating interruptedly.

One spring end is fixed to the blue lever. A slight grip between the spring and the yellow shaft is needed. Torsion spring allows motion transmission only in clockwise direction. The spring helix direction (right-handed in the video) decides the transmission direction.

The rotation direction that tends to wind up the spring is transmitted to the yellow output shaft due to friction force between the spring and the shaft.

For the inverse direction the yellow output shaft may rotate if there is no braking force or load applied to it.

The mechanism is for light duty works and where the kinematic relation between the input and output is not required strictly.

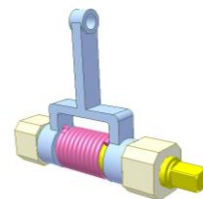

Friction ratchet mechanism 4

http://youtu.be/sRkZ_EgUIRQ

Input: blue oscillating lever with a threaded portion on its shaft.

Output: yellow inner cone disk rotating interruptedly.

The light friction of pink spring-loaded pins keeps the green outer cone disk (split for easy understanding) from rotating with the lever at moment when the lever changes its motion direction. Thus the green disk moves a little like a nut back and forth along the threaded portion of the lever. This motion creates or removes the contact between two disks (engagement or disengagement).

Thread direction (right-handed in the video) decides the transmission direction.

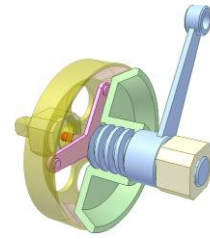

Friction ratchet mechanism 5

<http://youtu.be/QCvbg2p0Uns>

Input: blue oscillating lever.

Output: brown V-shaped groove wheel rotating interruptedly.

Yellow flat spring maintains contact between pink pawl and the wheel.

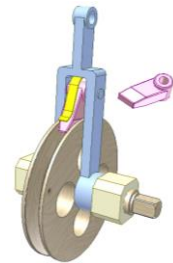

Friction ratchet mechanism 6

<http://youtu.be/tlwmkvEeZLQ>

Input: green oscillating lever.

Output: orange wheel rotating interruptedly.

Red flat spring maintains contact between yellow wedges and the wheel.

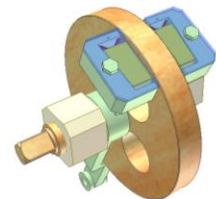

Friction ratchet mechanism 7

<http://youtu.be/78l17ntJeqo>

Input: pink crank.

Output: yellow wheel rotating interruptedly.

Violet pin keeps grey shoe in position during non transmission time.

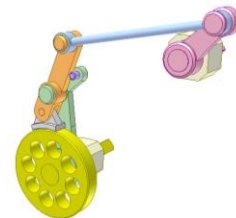

Friction ratchet mechanism 8

<http://youtu.be/4C8WE6frs9E>

Input: blue oscillating lever.

Output: yellow wheel rotating interruptedly.

Gear force of the gear rack drive creates friction on the contact cylindrical surface between the rack and the wheel for transmission.

Orange plate prevents the rack from leaving out during non transmission time.



Friction ratchet mechanism 9

https://youtu.be/6nmQVOwN_sl

Input: yellow oscillating lever.

Output: blue shaft rotating interruptedly.

Pink pin can slide in the lever hole. Annular groove of the blue shaft contacts the pin flat bottom. Blue spring maintains this contact.

Transmission happens only when the input turns clockwise when the pin is wedged against the blue shaft.

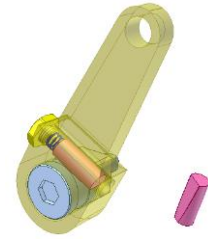

Quiet ratchet mechanism 1

<http://youtu.be/xsCE1E7jLI>

Input: pink crank rotating continuously.

Output: yellow ratchet wheel rotating interruptedly.

Four-bar linkage (pink crank, blue conrod and block of orange pawl and green rocker) makes the green rocker oscillate.

A violet stopper is mounted on the green rocker.

Measure to create some breaking force for the green rocker is not shown.

The mechanism is quiet because when the rocker goes back, the pawl does not contact the wheel.

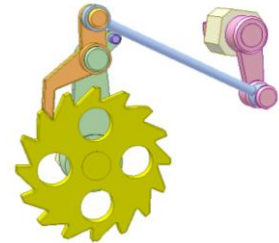

Quiet ratchet mechanism 2

<http://youtu.be/OYhx7OXYKQA>

Input: pink crank rotating continuously.

Output: yellow ratchet wheel rotating interruptedly.

Coulisse mechanism (pink crank, blue slider and green slotted rocker) makes the green rocker oscillate.

Violet crank has a pin for orange pawl. Pink spring creates some breaking force for the violet crank.

Two cyan pins on the green rocker contact the pawl.

The mechanism is quiet because when the rocker goes back, the pawl does not contact the wheel.

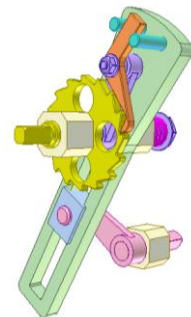

Quiet ratchet mechanism 3

<http://youtu.be/9W9wgFsOVIA>

Input: pink crank rotating continuously.

Output: yellow ratchet wheel rotating interruptedly.

Six-bar linkage (pink crank, blue conrod, yellow and violet levers, orange pawl and green rocker) makes the green rocker oscillate.

Two red stoppers are mounted on the green rocker.

Measure to create some breaking force for the green rocker is not shown.

The mechanism is quiet because when the rocker goes back, the pawl does not contact the wheel.

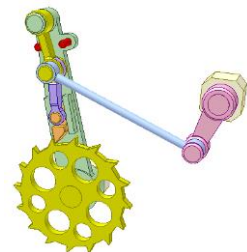

Ratchet mechanism 36

<https://youtu.be/iy10f3MF5e4>

Input: pink crank rotating continuously.

Output: blue ratchet wheel rotating interruptedly.

Orange pawl of cylinder shape and round profiles of the ratchet teeth help to reduce wear for this mechanism due to large contact area.

Friction on output side keeps the blue shaft immobile when the pawl slides on the ratchet wheel teeth.

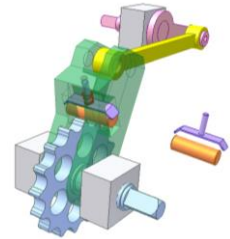

Escapement 1

http://youtu.be/fC8D_KzMGrk

Pink gravity pendulum performs a harmonic angular oscillation.

Green ratchet wheel tends to rotate clockwise due to blue weight.

The pink anchor allows the wheel rotate only two teeth during one oscillation of the pendulum.

Tick-tock sound is caused when the anchor collides the wheel teeth.

The mechanism is used in pendulum clocks where the wheel motion is transmitted to hands through a gear train to show time.

Besides the wheel transfers energy to the pendulum (timekeeper) to replace the energy lost to friction during its cycle and keep the timekeeper oscillating.



Escapement 2

<http://youtu.be/S6ptnwOtpdQ>

Orange pendulum performs a harmonic angular oscillation.

Green pin wheel tends to rotate clockwise due to blue weight.

The pendulum allows the wheel rotate only two teeth during one oscillation of the pendulum.

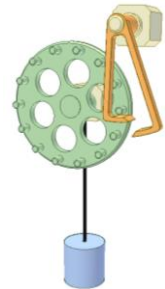

Escapement 3

http://youtu.be/D49F90k7_vE

Orange pendulum performs a harmonic angular oscillation.

Green pin wheel tends to rotate clockwise due to blue weight.

The pin number on each circle of the wheel is Z.

The pendulum allows the wheel rotate an angle of $360/Z$ deg. during one oscillation of the pendulum.



Escapement 4

http://youtu.be/C26G-M_cNjI

Green pendulum performs a harmonic angular oscillation.

Blue wheel tends to rotate counterclockwise due to grey weight.

Two identify pawls are mounted on both sides of the pendulum.

The mechanism allows the wheel rotate two teeth during one oscillation of the pendulum.



Escapement 5

<http://youtu.be/pN9COn0b4Dg>

Yellow pendulum performs angular oscillation.

Twin ratchet wheel tends to rotate counterclockwise due to green weight.

The mechanism allows the wheel rotate one teeth during one oscillation of the pendulum.

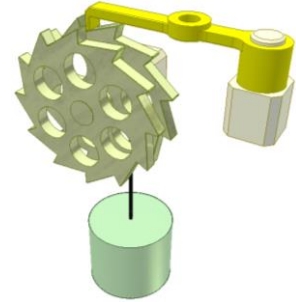

Escapement 6

<https://youtu.be/wC-hx5sTGTo>

Input: ratchet wheel of Z teeth rotating continuously.

Output: yellow pawl oscillating.

1 revolution of the ratchet wheel corresponds Z oscillations of the pawl.

Key factor: center of mass of the pawl must be higher than its rotary axis.

Another way is using spring toggle mechanism:

<http://youtu.be/u4oW1ZiiRGA>

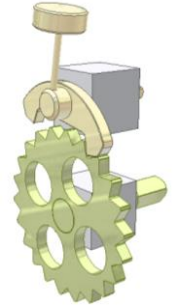

Spatial ratchet mechanism 1

<http://youtu.be/Hev7Im-DhVA>

Input: eccentric shaft rotating continuously.

Output: face tooth ratchet wheel rotating interruptedly.

Gravity maintains contact between blue pawl and the wheel.



Spatial ratchet mechanism 2

<http://youtu.be/TuJxhLaOJjo>

Input: pink crank rotating continuously.

Output: green ratchet wheel of tooth number Z.

Both go and back motions of yellow oscillating crank make the wheel rotate in the same direction.

In 1 rev. of the input, the output rotates $2/Z$ rev. with two dwells.

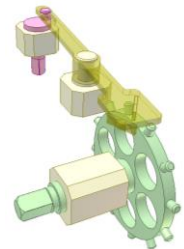

Spatial ratchet mechanism 3a

<http://youtu.be/OGGWPJUgAA8>

Input: orange oscillating crank.

Output: green twin ratchet wheel of tooth number Z.

Both go and back motions of the crank make the wheel rotate in the same direction.

In 1 rev. of the input, the output rotates $1/Z$ rev. with two dwells.

Angle deflection between the two ratchet wheels is $360/2Z$ deg.

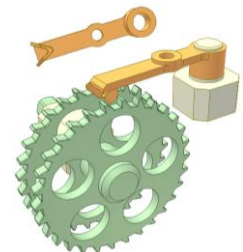

Spatial ratchet mechanism 3b

<http://youtu.be/HWZBdD80ZE4>

Input: blue oscillating crank.

Output: twin ratchet wheel of tooth number Z .

Both go and back motions of the crank make the wheel rotate in the same direction.

In 1 rev. of the input, the output rotates $1/Z$ rev. with two dwells.

Angle deflection between the two ratchet wheels is $360/2Z$ deg.

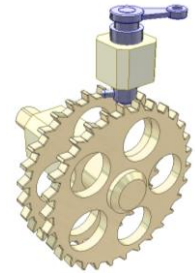

Spatial ratchet mechanism 4

<https://youtu.be/mWeZJ1jEGSo>

This is used for case when the input linear motion is parallel to rotary axis of the ratchet wheel.

Input: blue slider linearly reciprocating. Its source motion is not shown.

Output: green ratchet wheel (a helical gear) interruptedly rotating of angle A ($360/Z$ deg.).

Z is the gear tooth number.

A can be increased (2,3, ... times) by making the gear longer and increasing input stroke. Violet spring pin keeps the output immobile during backward stroke of the blue slider.

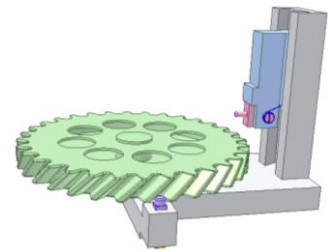

Ratchet mechanism 37

<https://youtu.be/b5JAK00oWFQ>

This is used for case when the input linear motion is parallel to rotary axis of the ratchet wheel.

Input: blue slider of violet cam linearly reciprocating. Its source motion is not shown.

Output: green ratchet wheel interruptedly rotating.

Yellow slider receives motion from the violet cam.

Blue spring pin keeps the output immobile during backward stroke of the yellow slider.

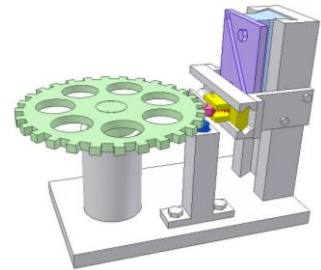

Mechanism for 90 deg. rotation 2

<https://youtu.be/gng7qlqfOIM>

Input: green shaft of a chamfered lever rotating continuously.

Output: one tooth blue ratchet wheel that quickly turns 90 deg. and then stops. One revolution of the input corresponds one revolution of the output.

The green lever pulls the wheel via blue spring.

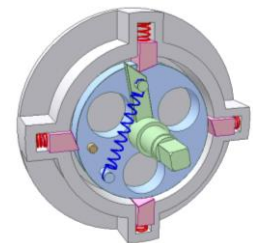

Mechanism for rotary limitation

<http://youtu.be/BLmpNDZX6Ts>

The output pink shaft is always under a moment caused by the blue weight. The green disk plays role of regulation. In its one revolution the output can turn $1/8$ rev. only.

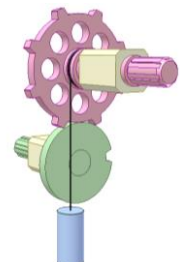

2.4. Pin drives

Interrupted rotation 1

<http://www.youtube.com/watch?v=WK2dRTJvN3o>

1 revolution of the green shaft corresponds a half-revolution of the blue one.

The driving and driven shafts rotate in the same direction.

The shafts are parallel.



Interrupted rotation 2

<http://www.youtube.com/watch?v=43FM0QRNS4Q>

1 revolution of the green shaft corresponds one-sixth-revolution of the blue one.

The driving and driven shafts do not rotate in the same direction.

The shafts are parallel.



Interrupted rotation 3

<http://www.youtube.com/watch?v=LsysC380Cdw>

1 revolution of the blue shaft corresponds one-sixth-revolution of the green one.

The shafts are perpendicular to each other.

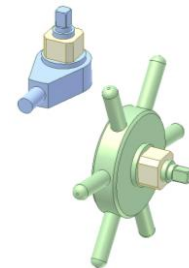

Interrupted rotation 4

http://www.youtube.com/watch?v=IX_TErmp4nc

1 revolution of the blue shaft corresponds one-third-revolution of the green one.

The shafts are perpendicular to each other.



Interrupted rotation 5

<http://www.youtube.com/watch?v=gG0dUrBT79k>

1 revolution of the blue shaft corresponds one-fourth-revolution of the green one.

The two shafts are skew at angle of 45 degrees.

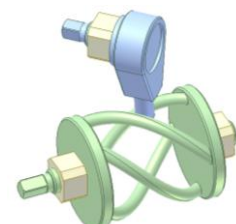

Interrupted rotation 6

<http://youtu.be/8tSOQDxLYvo>

1 revolution of the blue shaft corresponds one-fifteentth-revolution of the green one.

The two shafts are skew at angle of 90 degrees.

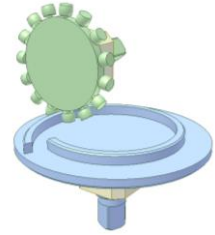

Interrupted rotation 7

<http://www.youtube.com/watch?v=H5ZLztp5uw>

1 revolution of the blue shaft corresponds one-twelfth-revolution of the green one.

The two shafts are skew at angle of 90 degrees.

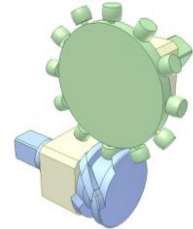

Interrupted rotation 8

<http://www.youtube.com/watch?v=EX2Adzx53FE>

1 revolution of the blue shaft corresponds one-twelfth-revolution of the green one.

The two shafts are skew at angle of 90 degrees.

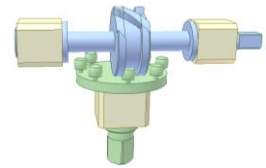

Interrupted rotation 9

http://www.youtube.com/watch?v=eT_bglEK_7s

1 revolution of the blue shaft corresponds one-sixth-revolution of the green one.

The driving and driven shafts rotate in the same direction.

The shafts are parallel.

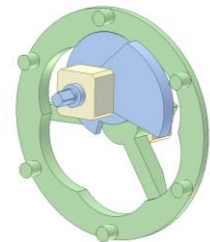

Interrupted rotation 10

<http://www.youtube.com/watch?v=5RG3fCh4kqs>

1 revolution of the blue shaft corresponds one-sixth-revolution of the green one.

The driving and driven shafts do not rotate in the same direction.

The shafts are parallel.

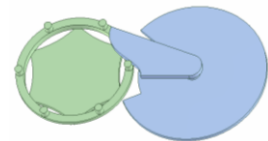

Pin gear drive 1K

<http://youtu.be/N37KHV8CD6M>

The green gear rotates interruptedly. During 1 revolution of the pin gear the green gear rotates 1 revolution and pauses.

Motion and dwell relation for the green gear can be easily adjusted by adding or cutting the pink pins.

The device to keep the green gear immobile during its dwell is not shown.

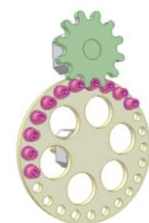

Pin gear drive 1N

http://youtu.be/B8dsC_QNyVg

Input: the cyan shaft having an arm.

Output: the pink pin wheel.

In 1 revolution of the cyan shaft, the arm makes the output rotate 1/8 rev. The green rim keeps the output immobile during its pause period.

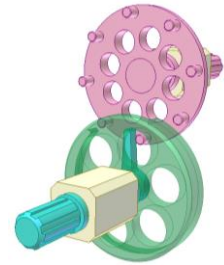

Intermittent rotation mechanism

http://youtu.be/JdJNG3_dIQ8

Input: blue disk of two cyan pins rotating continuously.

Output: orange shaft of two three wing disks rotating interruptedly.

1 rev. of the input makes the output rotate 120 deg.

Beside keeping the output shaft immobile during its dwells, the blue disk also participates in motion transmission.

The mechanism can work for two rotation directions of the input. In case of one direction one cyan pin is enough.



Transmission with mutilated tooth gear

<http://youtu.be/ITEHVWizRPI>

Green driving disk of width w has a tooth groove and a red pin nearby.

Yellow driven gear of width $2w$ has an even number of standard spur gear teeth. They alternately have full and half-width (mutilated) teeth.

During the dwell period, two full-width teeth are in contact with the circumference of the driving disk, thus locking the gear. The mutilated tooth between them is in front of the driver. At the end of the dwell period, the red pin contacts the mutilated tooth and turns the driven gear around one circular pitch. Then the full-width tooth engages the tooth groove and the driven gear moves around one more pitch. The dwell period starts again and the cycle is repeated. Totally in one revolution of the driver, the driven gear turns two circular pitches.

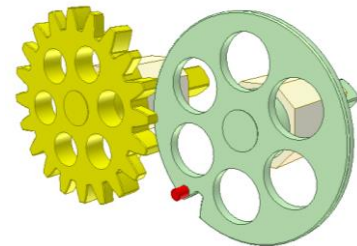

Interrupted rotation 11

<http://youtu.be/bJFFoWd2Pr8>

Input: green disk of a red pin.

Output: yellow gear interruptedly rotating.

Inner cylinder on the green disk is for locking the output gear during dwell period. However shortly before and after the engagement of two teeth with red pin at the end of the dwell period, the inner cylinder is unable to cause positive locking of the driven gear. Consequently, a concentric auxiliary outer cylinder is added. Only two segments are necessary to obtain positive locking. Their length is determined by the circular pitch of the driven gear.

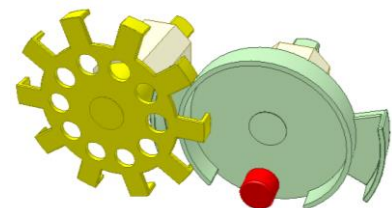

Cage gear for interrupted rotation 1

<https://youtu.be/VqcsbkQTFcE>

In 1 revolution of pink input shaft the green output shaft turns 180 deg. then pauses.

Yellow and violet rims keep the output immobile during dwell time. The mechanism can work with any rotary direction.

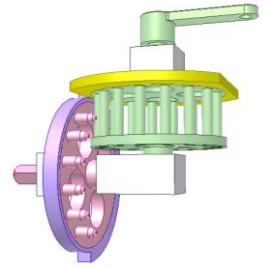

Cage gear for interrupted rotation 2

<https://youtu.be/U9vNlchlzHc>

In 1 revolution of pink input shaft the green output shaft turns 90 deg. then pauses.

Yellow and violet rims keep the output immobile during dwell time.

The input has 2 pins.

The output has 16 rods.

The mechanism can work with any rotary direction.

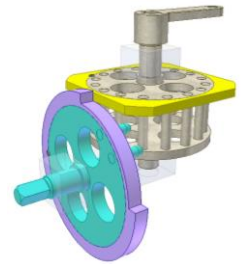

180 deg. interrupted rotation

<https://youtu.be/tn3fGrfSGU>

Green shaft tends to rotate clockwise thanks to a spiral spring located in the blue box (a weight and wire can be used instead of the spring).

Yellow cam controls 180 deg. interrupted rotation of the green shaft.

The spring that maintains the contact between the cam and pink slider is not shown.

Other driving source for the pink slider is possible, for example, a pneumatic cylinder.

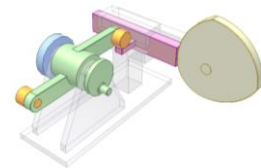

360 deg. interrupted rotation

https://youtu.be/TSK0Hqz_JPs

Grey shaft tends to rotate clockwise thanks to a spiral spring located in the blue box (a weight and wire can be used instead of the spring).

Yellow cam controls 360 deg. interrupted rotation of the grey shaft.

The spring that maintains the contact between the cam and green slider is not shown.

Other driving source for the green slider is possible, for example, a pneumatic cylinder.

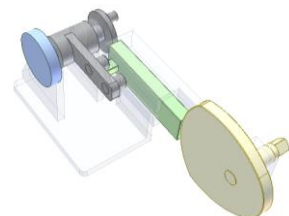

Simple mechanism for intermittent 90 deg. rotation

<https://youtu.be/iX5KulO8fFo>

Input: horizontal cam shaft.

Output: vertical shaft of two motions (up-down and rotary)

Brown bar angularly positions the vertical shaft.

Unusual thing: 2 (cam and friction drives) in 1.

Disadvantage: considerable wear when the vertical shaft does not rotate.

In term of function this mechanism is equivalent to the spatial Geneva drive

<https://youtu.be/Uv4TaxKyuw>

This video was made based on:

<https://youtu.be/xrUemSnwSFg>

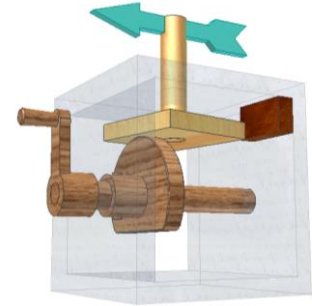

Simple mechanism for intermittent 120 deg. rotation

<https://youtu.be/Hikxwigs8-l>

Input: horizontal cam shaft.

Output: green 3-pointed star that rotates intermittently. It has prismatic joint with blue vertical shaft of two motions (up-down and rotary).

Orange bar angularly positions the vertical shaft.

Unusual thing: 2 (cam and friction drives) in 1.

Disadvantage: considerable wear when the vertical shaft does not rotate.

In term of function this mechanism is equivalent to the spatial Geneva drive

<https://youtu.be/rqDfalBVhIU>

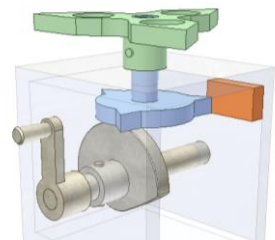

Simple mechanism for intermittent 180 deg. rotation

https://youtu.be/5IEGc_GlwvA

Input: horizontal cam shaft.

Output: green rectangle that rotates intermittently. It has prismatic joint with blue vertical shaft of two motions (up-down and rotary).

Orange bar angularly positions the vertical shaft.

Unusual thing: 2 (cam and friction drives) in 1.

In one revolution of the input the green rectangle rotates 180 deg., a thing that ordinary Geneva mechanisms can not get.

Disadvantage: considerable wear when the vertical shaft does not rotate.

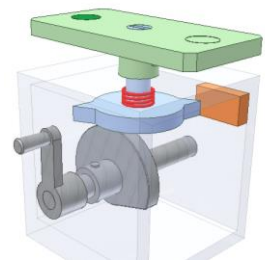

Simple mechanism for intermittent 360 deg. rotation

<https://youtu.be/RoNH0YXpW2c>

Input: horizontal cam shaft.

Output: green rectangle that rotates intermittently. It has prismatic joint with blue vertical shaft of two motions (up-down and rotary).

Orange bar angularly positions the vertical shaft.

Unusual thing: 2 (cam and friction drives) in 1.

In one revolution of the input the green rectangle rotates 360 deg., a thing that ordinary Geneva mechanisms can not get.

Disadvantage: considerable wear when the vertical shaft does not rotate.

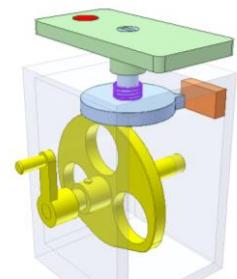

Interrupted rotation 13

<https://youtu.be/KBY359PCh3A>

Input: yellow crank shaft.

Output: blue shaft of 4 pins.

The two shafts are not coaxial.

One input revolution corresponds 90 deg. rotation of the output.

For the output: pause time / rotary time = 2 / 1

Violet ring (fixed to the blue shaft) and orange sector (fixed to the yellow shaft) are for keeping the output shaft immobile during pause time.

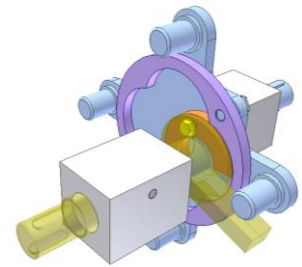

Interrupted rotation 14

<https://youtu.be/4Rm6DvxKvxE>

Input: yellow crank shaft.

Output: blue shaft of 2 pins.

The two shafts are not coaxial.

One input revolution corresponds 180 deg. rotation of the output.

For the output: pause time / rotary time is around 1 / 1.

Violet ring (fixed to the blue shaft) and orange sector (fixed to the yellow shaft) are for keeping the output shaft immobile during pause time.

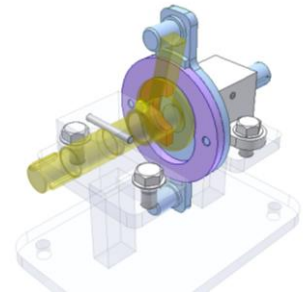

2.5. Bars

Linkage for 180 deg. interrupted rotation 1

<https://youtu.be/-47IVdMBYB0>

Input: orange crank.

Output: blue rocker of straight groove.

In 1 rev. of the input, the output turns 180 deg. then stops.

Pause time corresponds around one fourth of of working period.

Crank radius: a .

Length of green conrod: $b + c$

Center distance of two stationary bearings: d

$d = (b + c) - a$

In this video: $a = 50$; $b = 120$; $c = 180$; $d = 250$

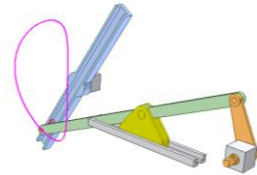

Linkage for 180 deg. interrupted rotation 2

<https://youtu.be/b9Wk04QEIYE>

Input: pink crank.

Output: green rocker of straight groove.

Crank radius: a .

Length of blue bar: $6a$

Distances between stationary bearings: $1.5a + 3.5a$

Blue line is locus of the yellow slider center.

In 1 rev. of the input, the output turns 180 deg. then stops.

Pause time corresponds more than 1/2 of working period.

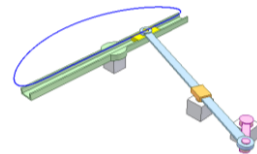

90 deg. interrupted rotation

<https://youtu.be/THXqlwZ8s9M>

Input: green pulley.

Output: pink crank interruptedly rotating 90 deg.

Input and output are coaxial.

Blue slider moves in runway of the pink crank. Its blue pin moves along inner profile of the stationary guide (in glass).

Yellow T-shaped part is pivoted on the blue slider pin.

A surface of the yellow part always contacts with the guide outer profile.

The yellow part has a pin that moves in slot of the green input pulley.

The yellow part has complicated motion: successive translation and rotation.

In this video the ratio of motion and dwell periods $i = 1$. It depends on the distance between inner and outer profiles of the guide.

The side number (n) of the guide determines output rotary angle A .

$A = 360/n$ deg.

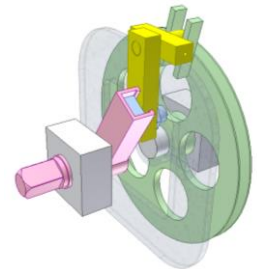

Coulisse mechanism 8

<https://youtu.be/UdhIN2o2dnM>

Pink, green and yellow links create a coulisse mechanism.

Input: pink crank.

Output: blue pin disk rotating interruptedly.

Device for keeping the output immobile during dwell stage is not shown.

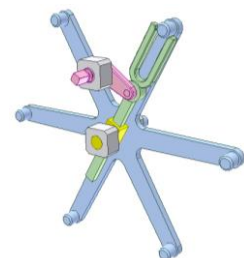

2.6. Combined mechanisms

Gear-rack-crank drive 1

<https://youtu.be/fnoylcq3Z7s>

Input: pink crank.

Output: blue gear shaft.

Center distance of rotary axes of the crank and the gear shaft C is equal to radius of rolling cycle of the gear.

In one input revolution the output rotates 360 deg. in the input rotary direction with dwell.

Alter center distance C and the crank radius to get various motion rules of the output. For example:

<http://youtu.be/lZddfZssoco>

http://www.youtube.com/watch?v=jNqET_RBLrs

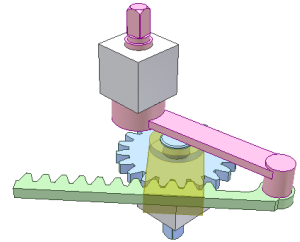

Chain drive 5B

<http://youtu.be/spJVvyv9Oo0>

The orange sprocket is immobile.

The pink gear and crank is driving. The coulisse rotates interruptedly with long dwells. Its motion depends on the ratio of tooth numbers of the two sprockets (8/8) and the chain link number (24). The green curve is locus of the center of the small slider.

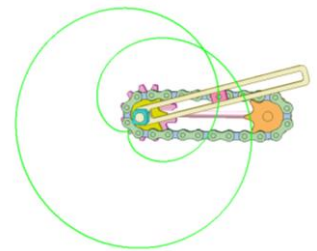

Chain drive 5C

<http://youtu.be/ZRo3mszuHHw>

The yellow sprocket is immobile.

The pink gear and crank is driving. The coulisse rotates interruptedly with long dwells. Its motion depends on the ratio of tooth numbers of the two sprockets (8/16) and the chain link number (28). The green curve is locus of the center of the small slider.

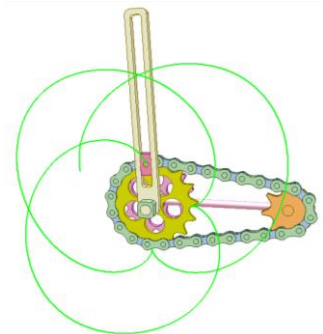

Translating cam and crank-slider mechanism 1

<http://youtu.be/OTNmbroZkqc>

Converting continuous rotary motion into intermittent rotary one.

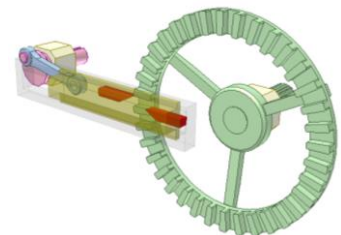

Translating cam and crank-slider mechanism 2

<http://youtu.be/QO2UoKZagIQ>

Converting continuous rotary motion into intermittent rotary one.

Input is the violet shaft.

The green double conrod oscillates on eccentric portion of the violet shaft. The magenta slider moves in slot of the pink oscillating runway. The red slider moves in slot of the yellow fixed runway and keeps the blue output disk immobile during its dwells.

The blue output disk of Z slots rotates $1/Z$ rev. during 1 rev. of the input shaft.

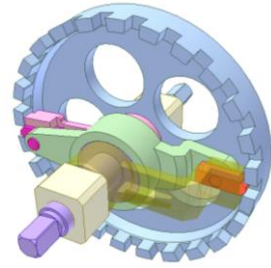

Cam and gear mechanism 4

<http://youtu.be/jvAg5HHLps4>

This is a combination of cam and bevel gear differential mechanisms. The bevel gears have the same tooth number.

Input is the orange spur gear shaft to which a cam is fixed. The cam's profile is a symmetric double Archimedes curve. The green spur gear shaft and the green bevel gear are fixed together.

Transmission ratio of the spur gear drive is 4.

The yellow bevel gear idly rotates on the pink arm carrying the red roller.

The blue output bevel gear has four dwells in one revolution of the green and blue bevel gears.

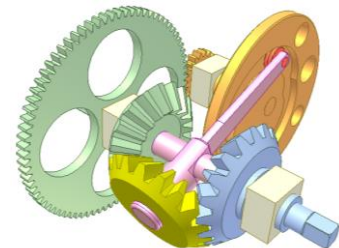

Worm Drive 5b: Rotating and translating worm

<http://youtu.be/fl2cBpDs1tE>

A worm drive, compensated by a cam on a work shaft, produces intermittent motion of the gear.

Input: green shaft.

Orange one start worm has prismatic joint with the green shaft.

Pink cam is stationary. The cam profile consists of two helix curves of opposite directions. Pitch of the curves is equal to the worm pitch.

Red spring maintains contact between the cam and violet pin.

In one revolution of the input, the gear stays immobile and then turns one tooth.

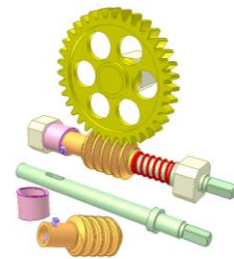

Gear-rack and parallelogram mechanism 3

<http://youtu.be/n1KsGiZ5Dcc>

Two cranks and yellow rack create a parallelogram mechanism.

Input: pink crank rotating continuously.

Output: green gear rotating interruptedly.

Blue conrod jointing two eccentrics of the cranks is for overcoming dead positions.

Measure to keep the gear immobile during its dwells is not shown.

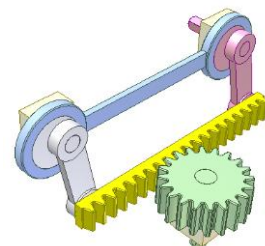

Geneva and gear drive for intermittent 360 deg. rotation

<https://youtu.be/kiCETCcY3YU>

Input: pink crank.

Blue gear (fixed to blue Geneva disk) rotates 90 deg. in 1/4 input revolution then stops.

Green block of gear and cam rotates 360 deg. in 1/4 input revolution then stops.

Tooth number of green gears: 20.

Tooth number of blue gears: 80.

Green cam moves orange slider.

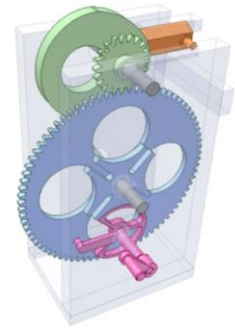

Successive 360 deg. rotation 1

https://youtu.be/_XdOD28zyu0

It is an application of the mechanism shown at:

<https://youtu.be/kiCETCcY3YU>

Input: orange gear-crank.

The rotation is transmitted to the end gear-crank (in blue) via a gear train of zigzag shape.

Brown gears (fixed to brown Geneva disks) rotate 90 deg. successively.

Green blocks of gear and cam rotates 360 deg. successively.

Tooth number of green gears: 20.

Tooth number of brown gears: 80.

Tooth number of other gears: 25.

Green cams move violet sliders one after another.

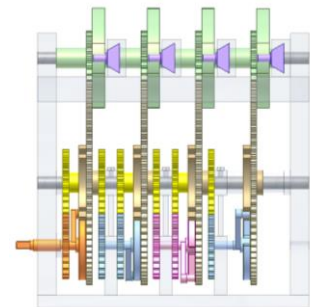

3. Converting continuous rotation into rotary oscillation

3.1. Bars

4-bar linkage mechanism

<http://www.youtube.com/watch?v=4dHKbPAQEY>

Length of red connection rod is smaller than radius of its revolution joint with the green rocker.

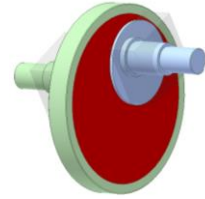

4-bar linkage mechanism

<http://www.youtube.com/watch?v=mTxpSpPOUmU>

Length of green rocker and radius of its revolution joint with the fixed link are equal.

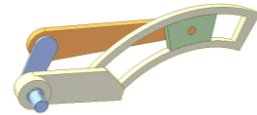

Fan swinging device

<http://www.youtube.com/watch?v=lusvDse493g>

A 4-bar linkage is used for fan swinging. The input link is the yellow connecting rod. The pink bar and the rotor house place the role of rockers.

For easy observation the transmission ratio is chosen less than in reality.



Four bar linkage 7

<http://youtu.be/qwB-WuX2Z18>

Four bars: blue, yellow, green and pink.

Input: the yellow bar rotating continuously.

Orange lever with positioning spring pin is for controlling the linkage.

When the orange lever enters in the slot of the blue bar, the latter is kept immobile and the green bar oscillates.

When the orange lever is not in the slot of the blue bar, the blue bar oscillates and the green bar does not move because of its huge mass.

The mechanism used to be applied for fan swinging control.

For example it can be used in this case:

<https://www.youtube.com/watch?v=lusvDse493g>

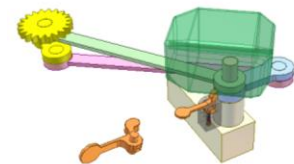

Auto rocker for hammock

http://youtu.be/gaD_Jl0YQHQ

Input: pink crank.

Output: blue rocker that has a hook serving as anchor point for hammocks or cradles.

Disadvantage: noise from revolute joints

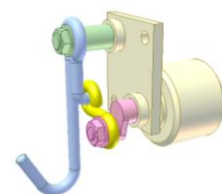

Coulisse mechanism 1

<http://www.youtube.com/watch?v=dqt1jkwLgs0>

$a < d$: the coulisse rocks

a: crank length; d: axle distance

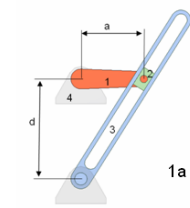

Coulisse mechanism 9

<https://youtu.be/0xAJs1CIO8U>

It is a structural embodiment of the mechanism shown by the sketch.

Grey input crank: 1

Green slider: 7

Orange disk: 8



Coulisse mechanism 10

<https://youtu.be/bs0OWutQfGU>

It is a structural embodiment of the mechanism shown by the sketch.

Grey input disk: 1

Orange part: 8

Blue disk: 7

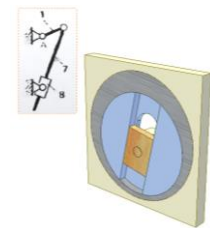

Coulisse mechanism 6

<http://www.youtube.com/watch?v=RvyKFLZi2SM>

Combination of two coulisse mechanisms.

The green rocker has working stroke slower than return one.

Velocity of the working stroke is nearly constant.

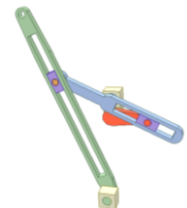

Coulisse mechanism with closed curve slot 1

<http://youtu.be/qaion6T6nVg>

Two identical mechanisms on the left give two different output motions due to different relative positions of the input and output at starting. Center distance of two grey fixed bearings and the eccentricities of circular slot of green and blue rockers are equal.

Input: pink cranks rotating regularly.

Upper mechanism: green rocker oscillates with large angle.

Lower mechanism: blue rocker is immobile.

The mechanism on the right is an ordinary coulisse one for comparison purpose.

Its yellow rocker oscillates with small angle.

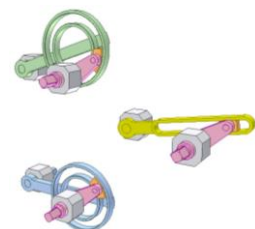

Coulisse mechanism with closed curve slot 2

<http://youtu.be/NwedertJEJl>

Two identical mechanisms give two different output motions due to different relative positions of the input and output at starting.

Input: cranks (green and pink) rotating regularly.

Upper mechanism: blue rocker oscillates with large angle.

Lower mechanism: yellow rocker oscillates with small angle and rather constant speed.

When the cranks and the rockers are in line, unstable positions happen. They can be overcome thanks to the rockers inertia.

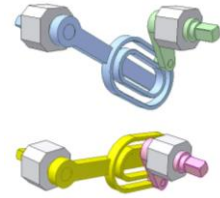

Adjustable coulisse mechanism 1

<https://youtu.be/CUPnP7zgrKg>

This video was made based on the design numbered as 935 in volume 2, Mechanisms in modern technic, I. Artobolevski.

Input: blue crank regularly rotating.

Output: green crank rotating or oscillating subject to violet slider position on the blue crank.

The violet slider has revolution joint with white slider of the green crank. Violet arrow is fixed to the violet slider. Let's call:

Center distance between two stationary bearings as D

Center distance between the violet slider pivot axis and the blue crank rotary axis as A (variable).

Turn yellow screw to get various positions of violet slider (to vary A).

Pay attention to yellow and red arrows on the blue crank.

When the violet arrow coincides with yellow arrow: $A = 0$

When the violet arrow coincides with red arrow: $A = D$

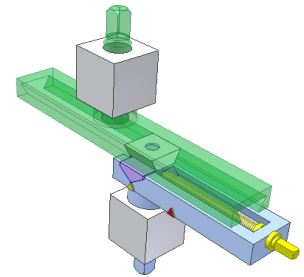

The video shows 4 cases in turn:

1. Violet arrow coincides with yellow arrow: green crank is immobile.
2. Violet arrow is between yellow and red arrows: green crank oscillates. Oscillating angle depends on the violet slider position.
3. Violet arrow coincides with red arrow: green crank rotates regularly. 2 revolutions of the blue crank correspond 1 revolution of the green crank. However its motion is not stable. To overcome it use more sliders:
<http://www.youtube.com/watch?v=gKQ-ro9gRcg>
https://youtu.be/dab5_kQH2vk
4. Violet arrow is on the right of red arrow: green crank rotates irregularly. 1 revolution of the blue crank corresponds 1 revolution of the green crank. The irregular level depends on the violet slider position.

The adjustment can be carried out only when the input crank stops.

The input and output are not coaxial.

Double coulisse mechanism 1

<https://youtu.be/fnTAaXEtLs>

This video was made based on the design numbered as 936 in volume 2, Mechanisms in modern technic, I. Artobolevski.

Input: pink crank regularly rotating.

Output: violet crank rotating or oscillating subject to blue slider position.

Glass double coulisse has revolution joint with the blue slider.

Let's call:

Input and output cranks radii as R .

Center distance between the glass coulisse rotary axis and the input crank axis as A (variable).

Center distance between the glass coulisse rotary axis and the output crank axis as B (variable).

Pay attention to blue arrow on the slider and green, red, yellow arrows on the runway.

When the blue arrow coincides with the green arrow: $B = R$

When the blue arrow coincides with the red arrow: $A = B$

When the blue arrow coincides with the yellow arrow: $A = R$

Turn orange screw to get various positions of the blue slider.

The video shows 4 cases in turn:

1. Blue arrow is between green and red arrows: The output rotates irregularly. Transission ratio = 1.
2. Blue arrow coincides with red arrow: The input and output rotate at the same velocity, regularly, although the glass double coulisse rotates irregularly.
3. Blue arrow is between red and yellow arrows: The output rotates irregularly. Transission ratio = 1.
4. Blue arrow is on the right of yellow arrow: The output oscillates.

The adjustment can be carried out without stopping the input crank.

For cases $B = R$ or $A = R$ the output motion is unstable.

If blue arrow is on the left of green arrow, the mechanism can't work.

The input and output are not coaxial.

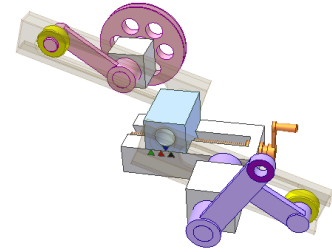

Coaxial double coulisse mechanism 1a

<https://youtu.be/dokb-RvXeY4>

Pink and violet cranks of the same radius are coaxial.

Input: pink crank regularly rotating.

Output: violet crank that irregularly (in general) rotates in the input rotary direction.

Green double coulisse has revolution joint with blue slider.

The irregular rotation level can be changed by adjusting center distance A between the green coulisse rotary axis and the crank axis (moving rotary axis of the green double coulisse).

The video shows the adjusting process from regular rotation (when $A = 0$) to irregular one and reversely.

The adjustment can be carried out without stopping the input crank.

Note:

- Yellow rollers must be set in opposite directions. If not, both cranks always rotate at the same velocity and direction.
- Distance A must not exceed the crank radius. If not, the output motion is unstable when the cranks are perpendicular to the green coulisse.

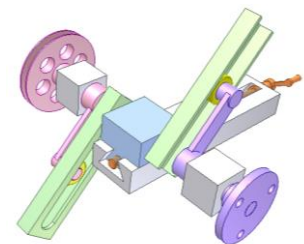

Coaxial double coulisse mechanism 1b

<https://youtu.be/obbUvGYLYuQ>

Pink and violet cranks of the same radius are coaxial.

Input: pink crank regularly rotating.

Output: violet crank performing rotary oscillation.

Green double coulisse has revolution joint with blue slider.

The output oscillating angle can be changed by adjusting center distance A between the green coulisse rotary axis and the crank axis (moving rotary axis of the green double coulisse).

The video shows the adjusting process to get large angle and reversely.

The adjustment can be carried out without stopping the input crank.

Spring slider (in brown) prevents the output crank from rotating full revolution at unstable positions of the output crank (when the output crank is perpendicular to the green coulisse).

The center distance A must be larger than the crank radius. If not, the output motion is unstable.

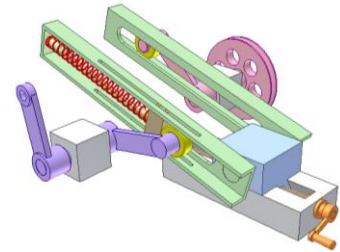

Linkage for oscillation with dwell 1

<https://youtu.be/OwgggEcq1Bo>

Input: pink crank.

Output: green rocker of circular slot.

Crank radius = radius of center circle of the slot.

Center distance of two stationary bearings = distance from the rotary axis of the rocker to axis of its circular slot.

The dwell happens at one end of the output stroke.

Dwell time corresponds one half of a revolution of the input.

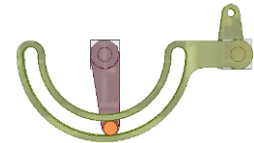

Dwell Rocker Linkage 1

<http://youtu.be/rhyoWC6abSI>

The green crank is the input. Choosing appropriate length of the violet rod in relation with the green locus enables the orange output rocker to have a long pause (half revolution of the green crank) at its rightmost position.

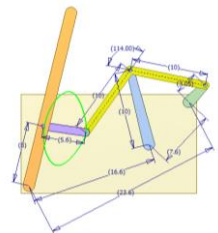

Dwell Rocker Linkage 2

<http://youtu.be/fECIXdX1G8M>

The green crank is the input. Choosing appropriate length of the violet rod in relation with the green locus enables the orange output rocker to have a pause in the middle of its stroke.

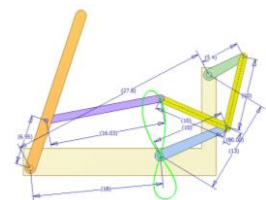

Dwell Rocker Linkage 3

<http://youtu.be/ueyak6YAadE>

The green crank is the input. Choosing appropriate length of the violet rod in relation with the green locus enables the orange output rocker to have a pause at the ends of its stroke.

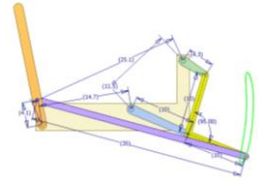

Six bar linkage of long output dwell

<http://youtu.be/G9jeOxlRbY0>

Input: orange crank.

Output: yellow rocker oscillating with long dwell at its extreme right position. This occurs because point C describes a green curve part that is approximately a circular arc with its center at P. The output is almost stationary during that circular arc.

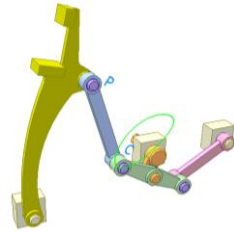

Six bar linkage for oscillation 1

https://youtu.be/GrKil_MQoVw

Pink bar length: 54

Blue bar length: 100

Green bar length: 100 + 100. Its angle: 80 deg.

Yellow bar length: 160

Orange bar length: 81

Input: pink bar rotating regularly

Output: orange bar oscillating.

1 input revolution makes the output oscillate two times, one fast, one slow.

Green line is locus of center of the revolution joint between green and yellow bars.

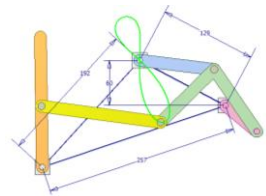

Six bar linkage for oscillation 2

<https://youtu.be/pcEc2Eagx0U>

Pink bar length: 55

Blue bar length: 100

Green bar length: 100 + 100. Its angle: 93 deg.

Yellow bar length: 190

Orange bar length: 90

Input: pink bar rotating regularly

Output: orange bar. 1 input revolution makes the output oscillate one time, slow turning down, fast turning up.

Green line is locus of center of the revolution joint between green and yellow bars.

The mechanism can be used for converting the oscillation of the orange bar into the continuous rotation of the pink bar (input is orange bar).

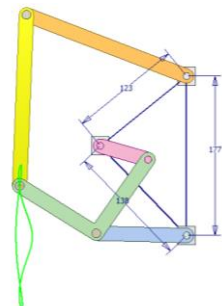

Spherical 4-bar linkage mechanism 1

<http://www.youtube.com/watch?v=fO4-0G0mS0>

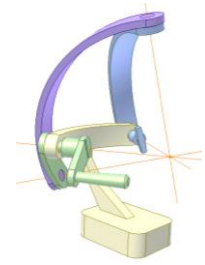

Spherical 4-bar linkage mechanism 4

http://www.youtube.com/watch?v=OE_BTQP3mE8

Axes of all revolution joints intersect at a common point.

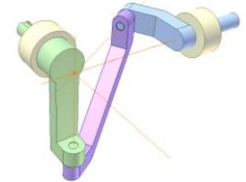

Spherical 4-bar linkage mechanism 5

<http://www.youtube.com/watch?v=M7r-6CFFuK8>

Axes of all revolution joints intersect at a common point.

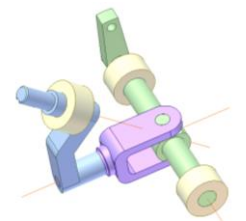

Spherical 4-bar linkage mechanism 6

<http://www.youtube.com/watch?v=E8WxHclAyMw>

Axes of all revolution joints intersect at a common point.

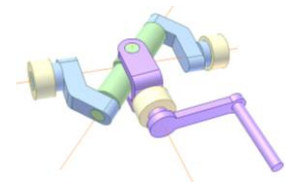

Spherical 6-bar linkage mechanism

<http://www.youtube.com/watch?v=IF2btFdXEOA>

Axes of all revolution joints intersect at a common point.

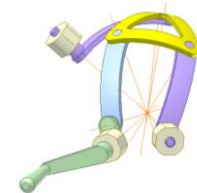

Spherical slider-crank mechanism 1a

<https://youtu.be/fc3r-geWGNc>

Input: pink crank.

Output: orange slider reciprocating along yellow stationary circular runway. Center O of glass sphere lies on axis of the said runway.

Axes of three revolution joints intersect each other at point O.

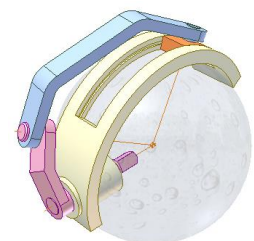

Spherical slider-crank mechanism 1b

<https://youtu.be/75Zts26jmW4>

It's an embodiment of "Spherical slider-crank mechanism 1a "

<https://youtu.be/fc3r-geWGNc>

Input: pink crank.

Yellow slider reciprocating along white stationary circular runway.
Axes of three revolution joints and the runway axis are concurrent.
Blue cross plays role of a connecting rod performing complicated motion around the concurrent point.

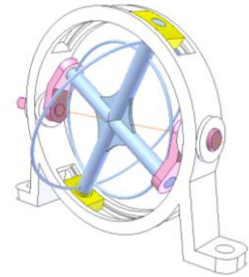

Spatial coulisse mechanism of oblique crank

<https://youtu.be/vYDhw6DwpV8>

Input: pink crank.

Output: orange rocker.

Red ball is connected with blue slider by a spherical joint.

Angular amplituda A of the output rocker depends on position of the ball along oblique pivot of the crank. Violet screw is used for altering the amplituda A. The video shows adjusting process from $A = 0$ to $A = \max$ and reversely.

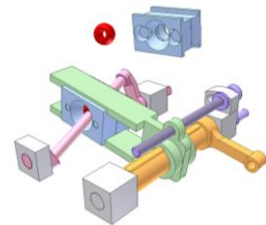

Spherical 4R mechanism 1

<http://youtu.be/NnWwkSXiCBw>

4R: 4 revolute joints.

Spherical: Joint center lines intersect at a common point.

Angle between center lines of revolute joints:

for the orange input link is $\gamma = 20$ deg.

for the green output link is $\beta = 60$ deg.

for the blue link is $\alpha = 70$ deg.

for the base link is $\delta = 30$ deg.

The output link oscillates.

Oscillation period is 2 rev. of the orange input link.

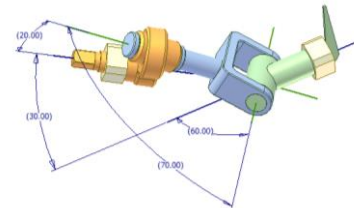

Spherical 4R mechanism 1a

<http://youtu.be/mUB5VDFCZ44>

4R: 4 revolute joints.

Spherical: Joint center lines intersect at a common point.

Angle between center lines of revolute joints:

for the orange input link is $\gamma = 20$ deg.

for the green output link is $\beta = 90$ deg.

for the blue link is $\alpha = 90$ deg.

for the base link is $\delta = 70$ deg.

The output link oscillates.

Oscillation period is 1 rev. of the orange input link.

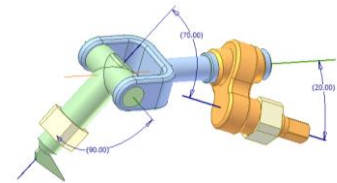

Space 4-bar mechanism 11 r

<http://www.youtube.com/watch?v=-KYomnT8xSc>

R-S-S-R mechanism

R-S-R-R: Joint symbols from input to output joint.

R: revolute

S: sphere

It does not meet Kutzbach criterion.

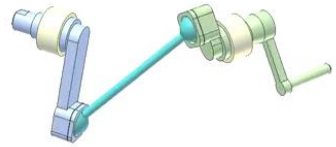

Spatial 4-bar linkage mechanism 2

<http://www.youtube.com/watch?v=n44LvAEzovk>

Shaft of bigger eccentricity is rocker.

Angle between two shafts is arbitrary.

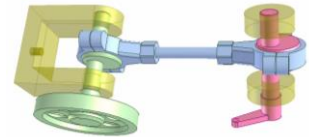

Spatial 4-bar linkage mechanism 4

<http://www.youtube.com/watch?v=ZWgupzGoUP8>



Oblique Crank - Rocker mechanism 1

http://www.youtube.com/watch?v=aYYJ-x_1nLg

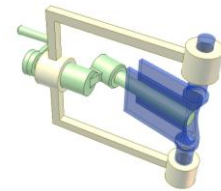

Oblique Crank - Rocker mechanism 2

<http://www.youtube.com/watch?v=pxQlrf1U7G8>

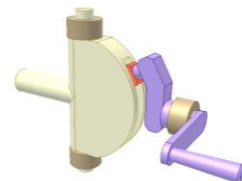

Oblique Crank - Rocker mechanism 3

<http://www.youtube.com/watch?v=mrxWgPrdWNw>

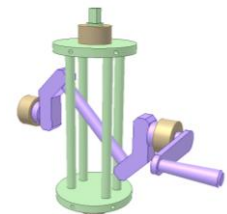

Spherical coulisse mechanism 1

<https://youtu.be/WPulyZNVVEw>

Input: blue crank.

Output: green rocker of circular slot.

Axes of three revolute joints intersect at one point.

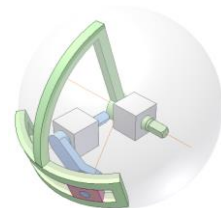

Rotary oblique disk mechanism 1a

<https://youtu.be/0deDO4iKqQo>

It's a spatial 4-bar linkage for converting rotation into angular oscillation.

Input: grey shaft to which an oblique disk is fixed. The latter makes blue T-shaped part oscillate thanks two green yokes.

Input and output axes are perpendicular to each other.

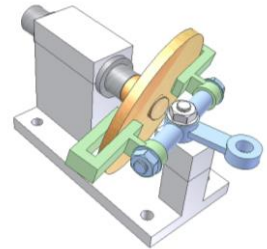

Rotary oblique disk mechanism 1b

<https://youtu.be/w2SmrvqiqQM>

Input: grey shaft to which an orange disk is pivoted. The latter makes blue T-shaped part oscillate thanks two green yokes.

Input and output axes are skew at an angle of 90 deg.

Pink screw is for moving the grey shaft axially thus adjusting angle A between the shaft and the disk.

If $A = 90$ deg. the blue part does not oscillate.

The video show adjusting process to get various oscillating angles even when the input shaft rotates.

If the input and output axes are intersecting (not skew), the adjusting process may get stuck when $A = 90$ deg..

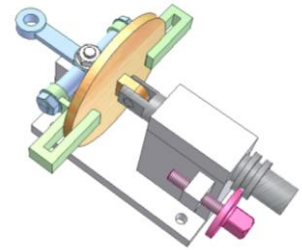

Rocker of adjustable angle

<https://youtu.be/hoQFUTzL4x4>

Input: blue shaft of circular slot.

A spherical 4-bar linkage consisting of cyan rocker, violet fork, green fork and the input shaft converts input rotation into angular oscillation of the cyan rocker.

Pink screw is for moving orange rotary slider axially thus adjusting angle A between input shaft and violet fork via yellow angular arm.

If $A = 0$ deg. the rocker does not oscillate.

The video show adjusting process to get various oscillating angles from 0 to 45 and 90 deg. when the blue shaft rotates and immobile (last scene).

Input and output axes are perpendicular to each other.

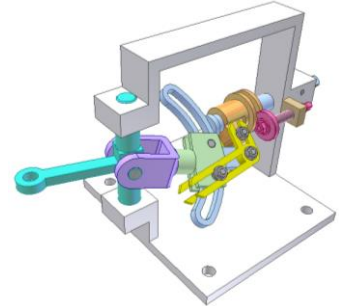

Oblique crank - rocker mechanism 2b

<https://youtu.be/7hrzllpQHJA>

It's a spherical mechanism.

Axes of 3 revolution joints are convergent.

Input: pink crank.

Oblique angle of the crank $A = 45$ deg.

Oscillating angle of blue rocker $B = 2A = 90$ deg.

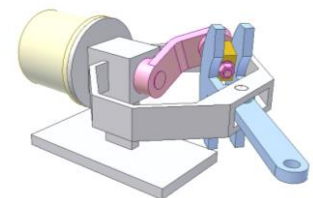

Spherical drive of balls

<https://youtu.be/cN1Uia5JkhE>

Steel balls (in red) riding within circular grooves convert a continuous rotary motion of the input (in pink) into an oscillating one of the output (in green).

This video was made based on the mechanism shown on page 170 of Sclater & Chironis, Mechanisms And Mechanical Devices Sourcebook, 2001, 485 p.

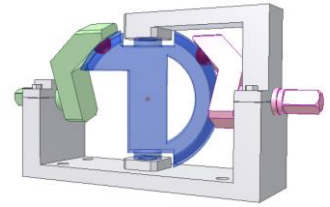

3.2. Gears

Transmission with teeth-uncompleted gears 12

<http://youtu.be/ndwCVs9ssl0>

The blue gear with external and internal teeth is driving. The orange gear oscillates with dwell. The dwell period is varied depending the tooth numbers of the blue gear.

The oscillation forward and backward angles may be different depending on numbers of external and internal teeth and stop positions of the orange gear.



Transmission with teeth-uncompleted gears 11

<http://youtu.be/cGcQhXtpFoY>

The orange shaft splined with the blue and yellow gears is driving. The pink output shaft oscillates with dwell. The forward and backward angles may be different depending on the tooth numbers of the blue and yellow gears and stop positions of the pink and green gears.

The device to keep the output shaft immobile during its dwell is not shown.

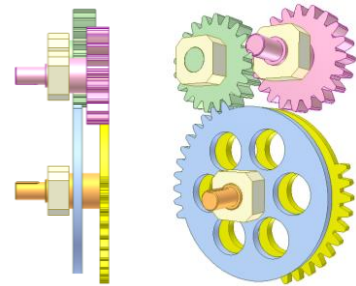

Triangular gear 1

<http://youtu.be/y99G7yej3-Y>

An input pink gear, rotating around fixed axis, engages with a gear of triangular shape. The latter has revolution joint with blue output crank.

The crank oscillates with dwell. The gravity maintains gear engagement.

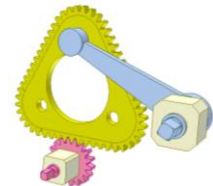

Pin gear drive 4A

<http://youtu.be/kz2vm9FCtjY>

The orange pinion is input. Its shaft has an end sliding in the closed circular slot of the yellow pin wheel. Because of meshing force the cyan slider carrying the orange pinion reciprocates. The yellow pin wheel oscillates with constant speed.

The rotation from a stationary source (the green pulley) is transmitted to the orange pinion through the Oldham coupling.

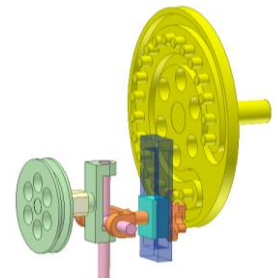

Pin gear drive 4B

<http://youtu.be/lo1c0V4GO-l>

The pink pinion is input. Its shaft has an end sliding in the closed curved slot of the yellow pin wheel. Because of meshing force the green slider carrying the pink pinion reciprocates. The yellow pin wheel oscillates with varied speed. The angle of oscillation can be more than 360 deg.

The rotation from a stationary source is transmitted to the pink pinion by suitable mechanisms: double Hook's joint, Oldham coupling, ...

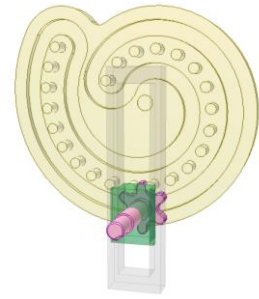

Transmission with teeth-uncompleted gears 14

<http://youtu.be/ya7IC-0JyTg>

The yellow gear is driving. The orange output shaft oscillates with dwell.

The tooth number of the yellow gear decides the oscillation angle and dwell time of the output.



Transmission with teeth-uncompleted gears 15

<http://youtu.be/eBlSbAaOOFc>

The green gear is driving. The blue output shaft oscillates with dwell.

The tooth number of the green gear decides the oscillation angle and dwell time of the output.

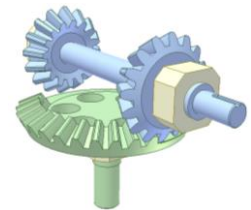

Transmission with teeth-uncompleted gears 16

<http://youtu.be/pZihUvOKYko>

The pink gear is driving. The blue output shaft oscillates with dwell.

The tooth numbers of the pink gear and the blue gears decide the oscillation angle and dwell time of the output.

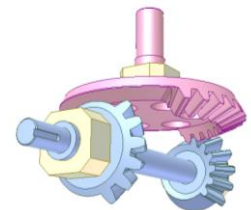

Bevel gears for angular reciprocation

<https://youtu.be/pOMmBK2fe8g>

In 1 revolution of orange input shaft, the grey output shaft turns around 178 deg. forwards then 178 deg. backwards.

The input has 7 teeth.

The output has 18 teeth.

The mechanism can work with any rotary direction.

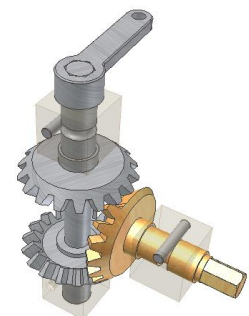

Cage gear for angular reciprocation 1

<https://youtu.be/uYOoax7TTrQ>

In 1 revolution of violet input shaft the yellow output shaft turns 360 deg. forwards then 360 deg. backwards.

The input has 13 pins.

The output has 16 rods.

The mechanism can work with any rotary direction.



Cage gear for angular reciprocation 2

<https://youtu.be/748pOoBNrUo>

In 1 revolution of violet input shaft the yellow output shaft turns 180 deg. forwards then 180 deg. backwards.

The input has 6 pins.

The output has 16 rods.

The mechanism can work with any rotary direction.

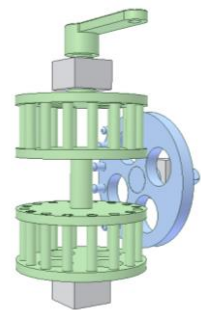

Bevel gears for interrupted oscillation

<https://youtu.be/3Wmu1MqL3v4>

In 1 revolution of orange input shaft, the blue output shaft turns 90, pauses, turns back 90 deg. and pauses.

Yellow disk and two cyan sectors keep the output immobile during dwell time.

The input has 3 teeth.

The output has 20 teeth.

The mechanism works with the shown rotary direction.

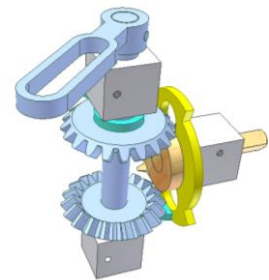

3.3. Cams

Disk cam mechanism DRr1

<http://youtu.be/vWlyxkMVBwc>

Dual cam.

The main cam is orange. The yellow one is added for cam geometrical closure.

Its profile must be designed to maintain permanent contact of both rollers with cams.

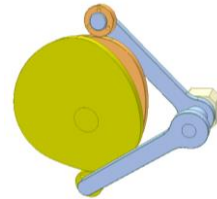

Disk cam mechanism DRp1

<http://youtu.be/a9GfqALLs1Q>

Dual cam.

The main cam is orange. The yellow one is added for cam geometrical closure.

Its profile must be designed to maintain permanent contact of both follower's planes with cams.

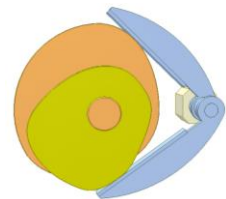

Cam mechanism of output with large oscillation angle

<http://youtu.be/e6jSX1CbgVw>

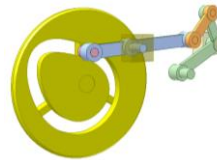

Disk cam assembly 1

<http://youtu.be/Fo1XpEqY6MY>

The cam assembly consists of orange cam and green one. They are fixed together by pink bolt. Their relative position can be adjusted to get various dwell times of the blue follower. Gravity maintains permanent contact between rollers and cam.

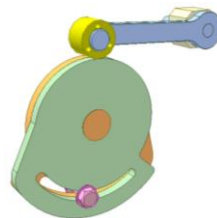

Disk cam assembly 2

http://youtu.be/paCOPz_h4iM

The cam assembly consists of a yellow round disk and some triangular cams. They are fixed together by cyan bolts. Their relative position can be adjusted to get various motions of the blue follower. Gravity maintains permanent contact between rollers and cam.

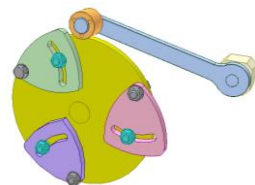

Disk cam mechanism DR1a

<http://youtu.be/Ru1jSCA9pfk>

The cam consists of two parts: blue round disk and yellow cam. Green follower moves one time during two revolutions of the cam.

The weight forces the follower toward the cam. Spring force is another possible way. There must be sufficient friction between the yellow cam and the blue pin to avoid accidental motion of the yellow cam.

The idea of this video is taken from

<http://www.youtube.com/watch?v=M7H-wnHxxXU>

by the introduction of a Youtube user, TheWindGinProject.

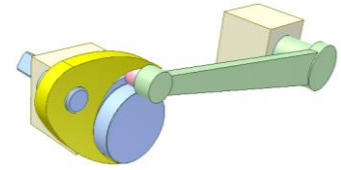

Disk cam mechanism DR1b

<http://youtu.be/eNyDPvqZBVs>

The cam consists of a blue round disk and $n (=3)$ yellow cams.

The red follower is immobile during one revolution of the blue disk and then moves $n (=3)$ times during the next revolution.

The weight forces the follower toward the cam. There must be sufficient friction between the yellow cams and the blue pins to avoid accidental motions.

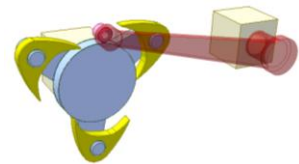

Sphere cam 1

<http://youtu.be/ Uld85q0hCc>

Roller axis, crank axis and cam rotary axis intersect at the center of the cam sphere.

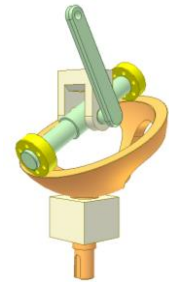

Sphere cam 2

<http://youtu.be/Hslk7-EIVis>

Roller axis, crank axis and cam rotary axis intersect at the center of the cam sphere.

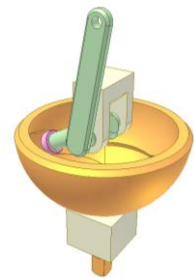

Sphere cam 3

<http://youtu.be/scnSa6f6QCE>

Roller axis, crank axis and cam rotary axis intersect at a point that is not the center of the cam sphere. The roller must be long enough to maintain contact between follower and cam that are of gravity constraint:



Barrel cam mechanism BR1

<http://youtu.be/qYRU5eu1HHI>

A barrel cam with milled grooves is used in sewing machines to guide thread. This kind of cam is also used extensively in textile manufacturing machines such as looms and other intricate fabric-making machines.

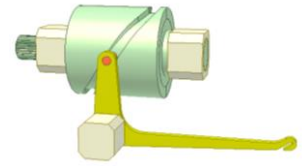

Globoid cam 1

<http://youtu.be/sYJ3BoLOXBw>

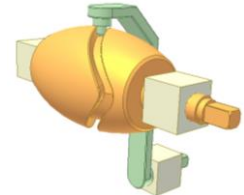

Globoid cam 2

<http://youtu.be/jHDk9hKQ4M8>

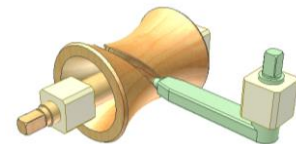

Oblique disk-rocker mechanism

http://www.youtube.com/watch?v=6CxfiO_afzo

A spherical mechanism: axes of all revolution joints intersect at a common point.

Rotation of the small bevel wheels around their axes is irregular.

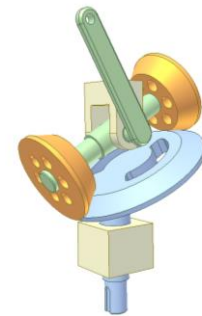

Torus cam

<http://youtu.be/mCRdbEv3ACI>

Helix torus joint.

Converting continuous rotation into oscillation between two 90 deg. skew shafts. The oscillating angle can be more than 180 deg.

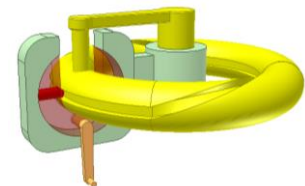

Angular oscillation with long dwells

<https://youtu.be/Evo-4RpVQJE>

Violet face cam receives motion from blue input shaft thanks to a bevel gear drive. The cam controls the oscillation of green bar via two orange pins and a snap mechanism that consists of the green bar, pink slider, yellow conrod, orange slider and blue spring.

Red screw is used for adjusting oscillating angle. Lower position of the orange slider gives smaller angle. The video shows the adjustment from large angle to small one and return process.

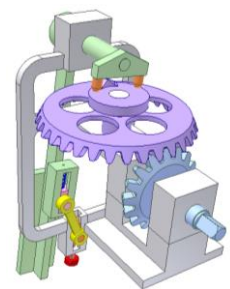

3.4. Belts and cables

Cable drive 13a

<http://youtu.be/cHOMfNQPTThY>

A simple way to convert continuous rotation to oscillatory motion. The spring creates friction between the yellow wheel and the cable. It acts like the mechanism in video “Application of rack pinion mechanism 2” of this channel.

However in case of large motion the spring deformation is too big that causes unnecessary load on the bearings. See “Cable drive 12b” and “Cable drive 12c” of this channel for the ways to overcome this weakness. The oscillatory angle can be more than 360 deg. by reducing the yellow wheel diameter.

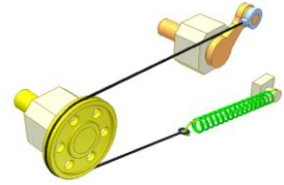

Cable drive 13b

<http://youtu.be/7IOxH017ZvU>

Converting continuous rotation to oscillatory motion. Using one crank more and gear drive reduces the spring deformation. See “Cable drive 12a” of this channel for comparison. Beside creating friction between the yellow wheel and the cable, the spring compensates velocity difference of the cable ends caused by the two cranks.

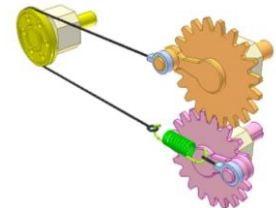

Cable drive 13c

http://youtu.be/2ECoeKLEj_c

Converting continuous rotation to oscillatory motion. Using twincam and two levers reduces the spring deformation. See “Cable drive 12a” of this channel for comparison. Beside creating friction between the yellow wheel and the cable, the spring ensures a permanent contact between rollers and cam and compensates velocity difference of the cable ends caused by the two levers.

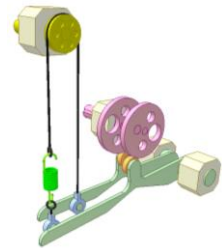

Chain drive 8B

<http://youtu.be/yuTpslrrlY>

Converting continuous rotation into oscillation with dwells at one end of the course.

Three sprockets are identical. The pink one is driving. The violet chain link has an axle for a revolution joint with the red slider.

The dwell time depends on axle distance of two blue sprockets.



Cable drive 25

<http://youtu.be/y8Squ43mUrE>

Converting continuous rotation of the pink crank to reciprocating rotation of the orange pulley.

The brown cable wraps 1 revolution around the orange pulley. Two cable ends are fixed to the green sector.

Rotation angle of the output orange pulley can be more than 1 revolution.

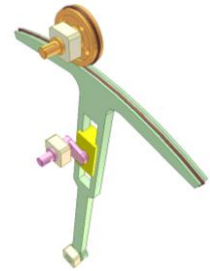

Cable drive 13d

<https://youtu.be/7afpvPPFAKw>

Input: pink crank rotating continuously.

Output: orange shaft having reciprocating rotary motion. It's amplitude can be more than 180 deg. or several revolutions (an ordinary 4-bar linkage can not reach such amplitude).

Black wire wraps about orange pulley 1 or many turns. Its ends are fixed to green bar. Red screw is for creating the wire tension to prevent the cable slippage. For the same purpose fix the cable middle point to the pulley if the cable is long enough.

The cable drive can be replaced with a gear-rack drive:

http://www.youtube.com/watch?v=jNqET_RBLrs

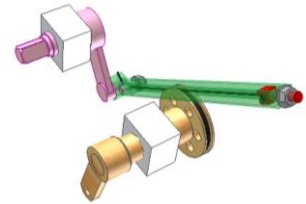

3.5. Combined mechanisms

Gear and linkage mechanism 5

<http://www.youtube.com/watch?v=zYdwKg6bYIc>

Pink and orange gears (tooth numbers: 16 and 24) have revolution joints with the blue rocker. The orange gear has revolution joint with green rocker. The two rocker and the orange gear create a 4-bar linkage. When the pink input gear rotates regularly, two rockers (green and blue) oscillate. Their motion depends on the 4-bar linkage dimension.

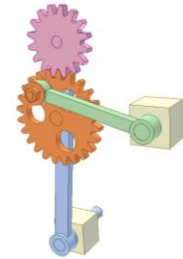

Drive for weaving machine beater

<http://youtu.be/n0rcMMRWuJK>

Input is pink gear.

Output is yellow beater of a weaving machine.

Green gear rotates on its eccentric portion. The red bar has a revolution joint with the concentric portion of the green gear.

The drive enables the beater to perform a quick push on the right and a long rest on the left.

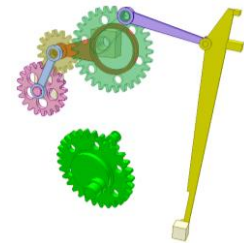

Gear and linkage mechanism 16

<http://youtu.be/pPxXYyWJE44>

Orange gear pitch diameter : $1.5R$

Pink gear pitch diameter : $0.75R$

Crank radius of orange gear : R

Crank radius of pink gear : $0.75R$

Length of blue and green bars : $2.9R$

Length of yellow bar : $2.6R$

Length of violet crank : $2.5R$

Distances between bearings: $2.25R + 1.5R + 3.2R$

Assembly position: as start position of the simulation video.

Input : pink gear rotating regularly.

The violet crank oscillates with two dwells in one working period of 2 revolutions of the pink gear because the locus (in blue) of a cyan pin contains two portions of radius that is approximately equal to the yellow bar length.

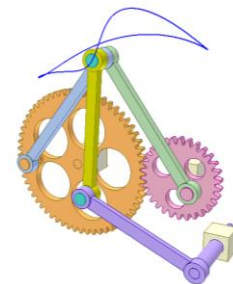

Oval gear 2

<http://youtu.be/c3qual5r2ks>

A blue gear of oval shape, rotating around fixed axis, engages with yellow gear of a gear-pulley block. The latter has revolution joint with the green angle arm that can rock around a fixed axis.

Orange slider can reciprocate in the slot of the green angle arm.

Input is pink pulley. The blue oval gear rotates irregularly. Brown bar reciprocates with dwell.

Weight of the brown bar (or spring) maintains permanent engagement of the gear drive.

Input can be the blue oval gear. In that case the belt drive isn't needed.

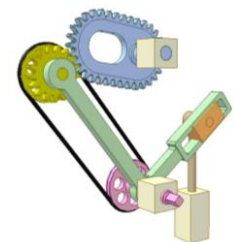

Application of rack pinion mechanism 2

http://www.youtube.com/watch?v=jNqET_RBLrs

Car windscreen wiper mechanism.

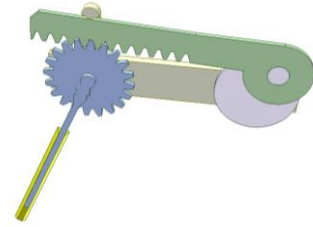

Rack and gear sector

<http://youtu.be/lZddfZssoco>

Input: orange crank

Output: yellow gear sector oscillating.

Green part maintains the engagement between blue rack and the gear sector.

The unusualness is: the gear sector oscillates around an eccentric axis, not its geometrical one. For comparison see:

http://www.youtube.com/watch?v=jNqET_RBLrs

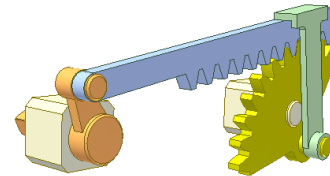

Opposite angular oscillations

<https://youtu.be/hollbm8Dnrg>

Green bevel gear gets the rotary reciprocating motion from a motor via a gear-rack mechanism. The action of the latter looks like a violin so this mechanism should be named as the violin mechanism.

The blue bevel gear and the green one rotate in opposite directions thanks to violet bevel gears.

This mechanism may be used for stirring machines as shown in the last scenes of this video.

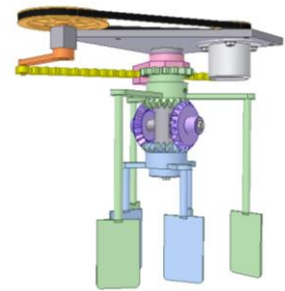

Rack gear clutch 1

<http://youtu.be/PUKfykGfkV4>

Input: pink crank that rotates continuously.

Output: yellow gear shaft that oscillates.

Use green lever to close or disclose the clutch via orange cam.

The mechanism is used in washing machines.

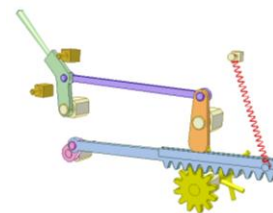

Reverse gear drive with dwell 1

<http://www.youtube.com/watch?v=2fVz5KIZllo>

Oscilating angle of two gears depends on:

- Position of the orange pin on the yellow input crank.
- Length of the bars attached to the gears.

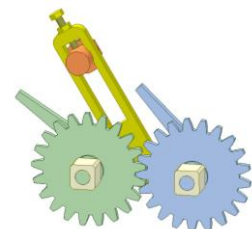

Two rocker mechanism with bevel gears

<http://youtu.be/zv-yK7XECYE>

Two rockers (in grey and green) oscillate while the input pink gear rotates continuously.

Bevel gears have the same tooth number. The orange gear shaft has an eccentric for the grey rocker. It is case of four-bar linkage, in which the conrod (orange eccentric) is the driving link.

To slow down the rocker oscillation, the transmission ratio of bevel gear drives can differ from 1.

Move the blue slider by turning the violet screw for getting various course positions of the green rocker.

Instead of bevel gear drives, worm or helical gear ones can be used.

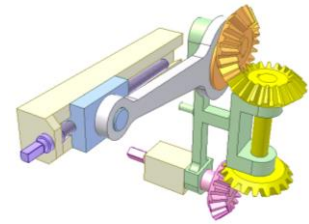

Gear-rack and parallelogram mechanism 1a

<http://youtu.be/kqCaE2yX6kU>

Two cranks and yellow rack create a parallelogram mechanism.

Input: pink crank rotating continuously.

Output: green gear performing harmonic oscillation. Oscilating angle depends on the crank radius.

Input and output axes are skew at 90 deg. angle.

Blue conrod jointing two eccentrics of the cranks is for overcoming dead positions.

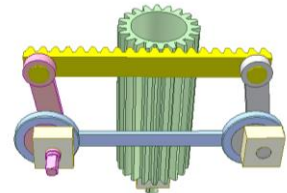

Gear-rack and parallelogram mechanism 1b

http://youtu.be/i6Dzv8I_5s0

Two cranks and yellow rack create a parallelogram mechanism.

Input: pink crank rotating continuously.

Output: green gear performing harmonic oscillation. Oscilating angle depends on the crank radius.

Input and output axes are skew at 90 deg. angle.

Output axis is not perpendicular to the plane created by two crank axes.

Blue conrod jointing two eccentrics of the cranks is for overcoming dead positions.

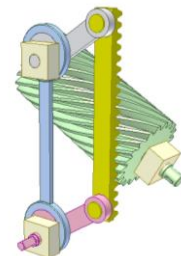

Gear-rack and parallelogram mechanism 2

<http://youtu.be/xbKb0dggmM4>

Two cranks and yellow rack create a parallelogram mechanism.

Input: pink crank rotating continuously.

Output: green gear oscilating with dwells at both stroke ends.

Oscilating angle depends on the crank radius and gear face widths.

Blue conrod jointing two eccentrics of the cranks is for overcoming dead positions.

Measure to keep the gear immobile during its dwells is not shown.

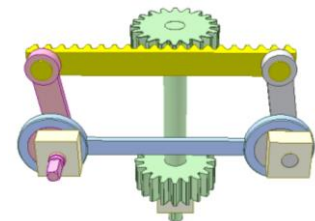

Mechanism for converting continuous rotation into 90 deg. oscillation to both sides with dwells 1

<https://youtu.be/7WFQdFjaXVU>

Input: green cam.

A coulisse mechanism is used to enlarge oscillation of the pink follower (from 20 deg. to 180 deg.).

Output motion of blue lever: Neutral rest - Turn left 90 deg. – Left rest - Return – Neutral rest - Turn right 90 deg. – Right rest – Return.

Its acceleration near neutral position is big.

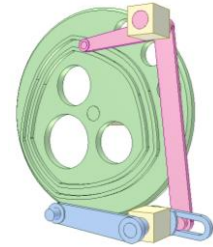

Mechanism for converting continuous rotation into 90 deg. oscillation to both sides with dwells 2

<http://youtu.be/kNQmjPjrUi0>

Input: green cam.

Two gear drives are used to increase oscillation of the pink follower (from 20 deg. to 180 deg.). Transmission ratio: $3 \times 3 = 9$.

Output motion of blue lever: Neutral rest - Turn left 90 deg. – Left rest - Return – Neutral rest - Turn right 90 deg. – Right rest – Return.

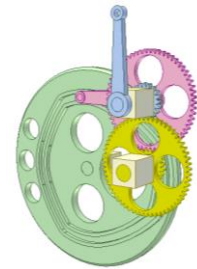

Fast cam follower motion

<http://youtu.be/Zs4gKdqFwGk>

Input: blue shaft with two gears fixed on it.

Yellow block and pink block rotates idly on a fixed shaft. Each block has identical cam. The yellow rotates faster than the pink.

Output: orange rocker. Its roller contacts both cams. Motion of the follower is as fast as in case there is no the pink cam but the working cycle is long (every three revolutions of the yellow cam).

Tooth number of the blue gear 12

Tooth number of the pink gear 18

Tooth number of the green and yellow gears: 15

The cycle can be very long by altering gear tooth numbers.

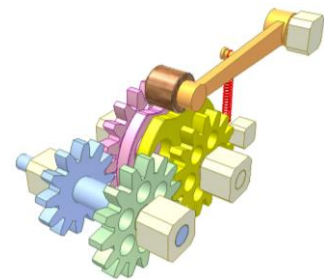

Cut-out cam

<http://www.youtube.com/watch?v=4RJhFvLlrOo>

A rapid rise and fall within 90 deg. was desired. This originally called for the pink cam contour but produced severe pressure angles. The condition was improved by providing an additional green cam which rotates 4 times faster than the pink cam.

The pink cam was then completely cut away for the 90 deg. The desired motion, expanded over 360 deg. ($90 \times 4 = 360$), is now designed into the green cam. This results in the same pressure angle as would occur if the pink cam rise occurred over 360 instead of 90 deg.

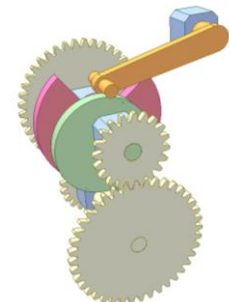

Barrel cam mechanism BT7

<http://youtu.be/gV9H8Gjp8KU>

Rotational motion is converted into oscillating motion with dwells. When moving in the cam's groove, the violet chain's pins has linear motion.

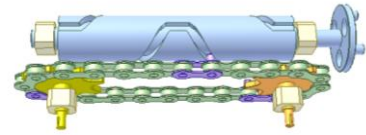

Barrel cam for reverse 180 deg. rotation 1

<https://youtu.be/LjZ12d6fT4s>

Input: pink shaft rotating regularly.

Green shaft is identical to the pink one and rotates with the same velocity and direction.

Output: yellow cam shaft oscillating with dwells at its stroke ends.

Oscillating angle: 180 deg.

The arcs of the two cranks are for keeping the output shaft immobile during its dwells.

It is a development of the mechanism shown at:

<http://youtu.be/gV9H8Gjp8KU>



Barrel cam for reverse 180 deg. rotation 2

<https://youtu.be/-PhB19njbCc>

Input: green shaft of two long pins rotating regularly.

Output: pink cam shaft of two crossed helical grooves oscillating with dwells at its stroke ends. Oscillating angle: 180 deg.

The arcs of the input are for keeping the output immobile during its dwells.

Pay attention to the ellipse section of the pins which helps the output rotate stably when the pins are at the crossed place of helical grooves. Long axis of the pin section ellipse is in the direction of the groove along which the pin moves.

It is a development of the mechanism shown at:

<http://youtu.be/gV9H8Gjp8KU>

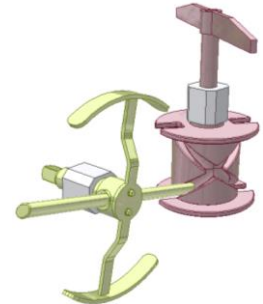

Geneva mechanism for reverse 90 deg. rotation

<https://youtu.be/d6fIM1f7DcQ>

Input: pink crank rotating regularly.

Blue crank is identical to the pink one and rotates with the same velocity and in opposite direction.

Output: yellow Geneva disk oscillating with dwells at its stroke ends.

Oscillating angle: 90 deg.

The sectors of the two cranks help keeping the output shaft immobile during its dwells.

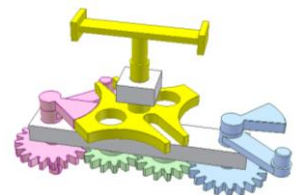

Geneva mechanism for reverse 120 deg. rotation

<https://youtu.be/SwdCKnGz0yg>

Input: yellow shaft rotating regularly.

Blue crank is identical to the violet one and rotates with the same velocity and in opposite direction.

Output: green Geneva disk oscillating with dwells at its stroke ends. Oscillating angle: 120 deg.

The blue sectors of the blue crank help keeping the output immobile during its dwells.

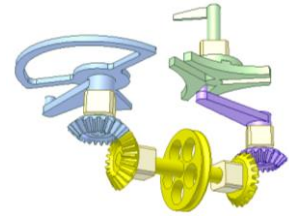

Dwell rocker mechanism 1

<http://youtu.be/8h9mjKA5SjQ>

The red crank is driving. The pink output gear shaft oscillates with dwell at its stroke ends. The oscillation angle and dwell time of the output depend on positions of the violet adjustable stoppers and position of the orange pin in the yellow sector slot.

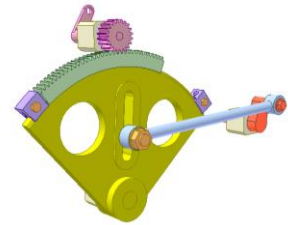

Sinus and rack pinion drive

<http://youtu.be/BLTQ4cNahXs>

Combination of a sinus mechanism (yellow crank and blue rack-slider) and rack-gear drive makes the green shaft oscillate with amplitude of 1 revolution.

The radius of the yellow crank is equal to $\frac{\pi \cdot D}{2}$. D is pitch diameter of the green gear.

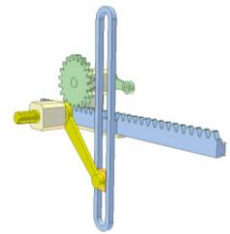

Chain drive 3A

http://youtu.be/WN01eHdUk_4

The coulisse rocks with long dwells at the ends of the stroke.

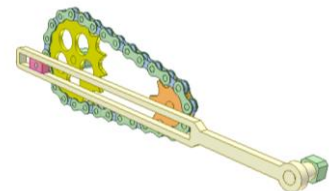

Chain drive 3B

http://youtu.be/_Xq5SSijUwM

The orange sprocket is driving.

The motion of pink crank and disk depends on the ratio of tooth numbers of the two sprockets (8/16) and the chain link number (28).

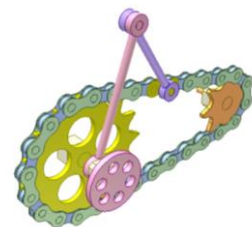

Chain drive 3C

<http://youtu.be/V7sbSgITXVA>

The orange sprocket is driving. The pink crank oscillates.

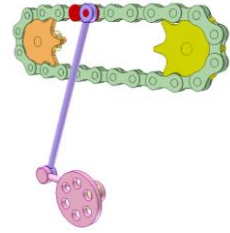

Gear linkage for 1 rev. oscillation.

<https://youtu.be/2MC8QBbAD0o>

Input pink crank.

Output: yellow gear shaft.

The input and output are coaxial.

One revolution of the input makes the output rotate forwards and backwards approximately one revolution (348 deg.).

Weaknesses of this mechanism: output rotation is not regular.

See mechanisms of the same function:

<https://youtu.be/ndwCVs9ssl0>

<https://youtu.be/cGcQhXtpFoY>

<https://youtu.be/lo1c0V4GO-I>

<https://youtu.be/eBIsbAaOOFc>

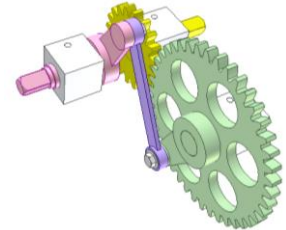

4. Altering rotary oscillations

Typewriter drive 2

<https://youtu.be/wON-9sGyWWA>

Two coulisse linkages are connected in series. The finger force of a typewriter (applied on pink bar) causes a strong hammer (in green) action at the roller from a light touch. Here high velocity of the hammer gives it a large kinetic energy.

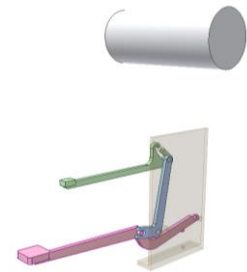

Slider crank and coulisse mechanism 1

<http://youtu.be/SdwlGoJ-3aq>

Input: blue crank that has turning angle α .

Output: orange bar that has turning angle β .

$\alpha, \beta = 0$ when the blue crank and the orange bar are in line with the fixed runway.

Distance between revolution joints of the green bar is $16 + 6$.

Distance between revolution joints (length) of the blue crank is 20.

In the α range from 0 to 20 deg., β is nearly double α with max error of 5%.

The mechanism can be applied for controlling ball retainer in Rzeppa joints.

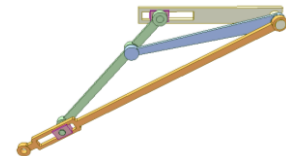

Gear rack drive for reversing rotation 1

<https://youtu.be/J8eCsw5nLsQ>

Green runway is kept immobile by its pin and a slot on the base.

Input: pink (or blue) gear.

Output: the other gear. It turns at the same input velocity but in opposite direction.

Disadvantage: turnable angle can not be large subject to rack length.

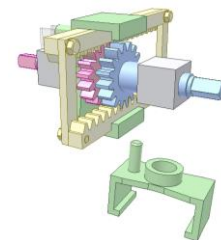

Two screw-slider drive

<https://youtu.be/SERbw7cdk3w>

Input: orange shaft. Lead of its helical slot is L_i .

Output: green shaft (coaxial with the input). Lead of its helical slot is L_o .

Output lead angle should not be less than 30 deg. to ease the output motion (to avoid self-locking).

Pink slider has a pin that contacts slots of both shafts.

Transmission ratio: $i = L_o/L_i$

The two shafts turn in the same direction if their helical slots are of the same hand and vice versa.

The video shows case when $L_o = 2 L_i$. Thread hands are opposite.

The two shafts turn in opposite directions. The orange turns 1 rev., the green turns $\frac{1}{2}$ rev.

If $L_o = L_i$, the mechanism becomes a coaxial reverser.

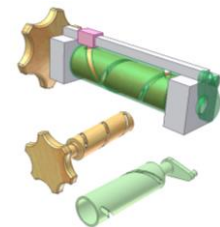

Helical joint reverser of rotary motion

<https://youtu.be/PCM-1X-dbxk>

Input: green outer tube of right hand helical slot.

Output: blue inner tube of left hand helical slot.

They rotate in opposite directions with the same velocity.

The helical slots have the same lead.

Red pin moves in both slots.

Pink slider moves in the base groove.

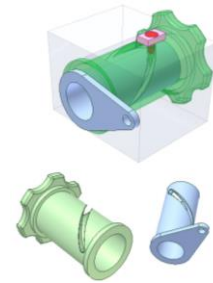

Facial cam 2

<https://youtu.be/jrlvTxpysAM>

Input: yellow shaft angularly reciprocating.

Output: green slider interruptedly linearly reciprocating.

Violet pawl makes blue face cam rotate in one direction.

A flat spring forces the pawl toward ratchet wheel of the cam.

Red spring maintains contact between the blue cam and cam follower fixed to the green slider.

Red and yellow pins restrict rotary angle of the input yellow shaft.

This mechanism is expected to be used for a prosthetic hand.

The yellow part is fixed to the forearm. The white part is fixed to the upper arm. The forearm rotation is used to control artificial fingers (not shown) via the green slider.

This design was made on request of a YouTube viewer from Netherlands.

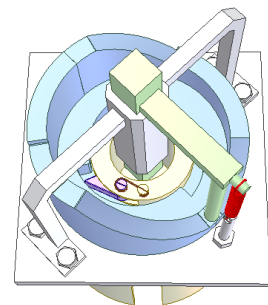

Screw reverser

<https://youtu.be/nDQ4uf3U3v8>

Input: grey screw.

Output: orange crank shaft.

Transmission ratio between the coaxial input and output is -1 (rotating in opposite directions with the same velocity).

The grey screw of h2 lead is in mesh with internal thread of the green nut-screw.

The base having internal thread of h3 lead is in mesh with external thread of the green nut-screw.

$h3 = 2.h2$

The threads are right-handed.

A pin fixed to the green nut-screw slides along longitudinal groove in the orange crank shaft hole.

In two last scenes one fourth of some links are cut off for easy understanding.

This mechanism needs to be verified in practice.

For calculation of this reverser refer to:

<http://www.youtube.com/watch?v=0P-ao2F3jvc>

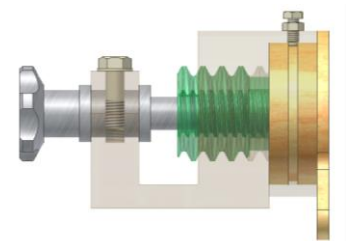

Coaxial pedals of opposite direction motions 1

https://youtu.be/qiY0BaeX_JA

It is a double slider-crank mechanism of common slider.
Velocities of two pedals are the same.

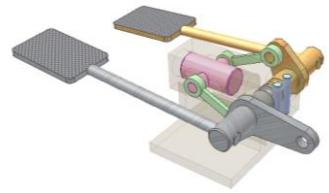

Coaxial pedals of opposite direction motions 2

<https://youtu.be/LefhdeZEjUw>

Velocities of two pedals are nearly the same.
Relative position between the pins of blue shaft or between the grooves of green shaft affects the velocity relation.

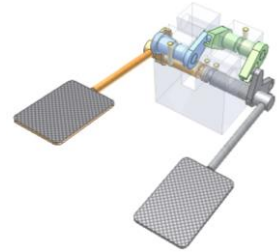

Coaxial pedals of opposite direction motions 3

<https://youtu.be/YCNXa3aHhoc>

Velocities of two pedals are the same.

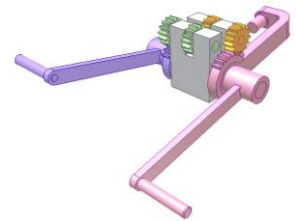

Barrel cam reverser 2

<https://youtu.be/m50spRqVHY4>

The input may be one among two levers (in blue and yellow). The remaining lever is the output.
They turn in opposite directions.
Pink slider translates thanks to the input barrel cam and turns the output barrel cam.

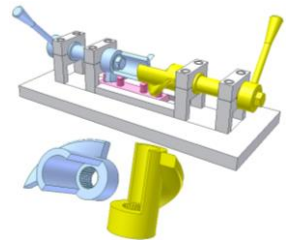

Archimedean cam reverser

<https://youtu.be/mOy9-S-pSQo>

The input may be one among two levers (in blue and yellow).
The remaining lever is the output.
They turn in opposite directions.
Two cams of Archimedean slot (in blue and yellow) are identical.
Pink slider translates thanks to the input cam and turns the output cam.
Pitch of the Archimedean slots must be big enough to prevent possible jam.

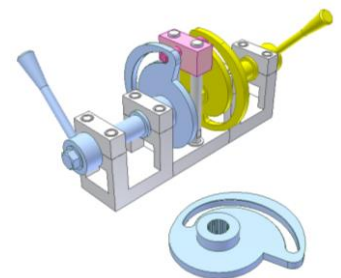

Reverser of Hobson's joints

<https://youtu.be/So9PgIDWl6I>

Blue and green cranks turn in opposite directions.
There is a dead position where violet part is vertical so the cranks only turn +/- 85 deg. in this video.

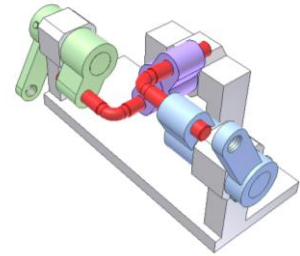

Reverse transmission between two spherical joints

<https://youtu.be/wnUOknxtgU>

Input: green lever that has spherical joint with the base.
Output: pink lever that has spherical joint with the base.
The levers have point-on-line joints (ball in cylindrical hole) with the yellow part. The latter has planar joint with the base.
Rotary directions of the two levers are opposite in any vertical plane that contains centers of the two spherical joints.

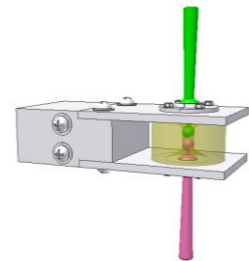

2D inverted pendulum

<https://youtu.be/wftXBezRHb4>

Inverted pendulum (in green) can perform its oscillation thanks to a regular pendulum (in pink) that is hidden in the base.
The pendulums have spherical joints with the base.
The pendulums have point-on-line joints (ball in cylindrical hole) with the yellow part. The latter has planar joint with the base.
Motion of the pink one is reversed motion of the green one in any vertical plane that contains centers of the two spherical joints.
If a suitable mass is fixed to lower end of the green pendulum, it will perform oscillations but it is not an inverted one.

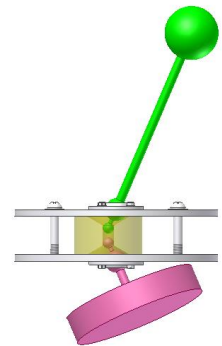

Angle doubling drive

<http://youtu.be/zwYQ9fy5CtQ>

This angle doubling drive will enlarge the oscillating motion of one machin member into an output oscillation of the other. If gears are employed, the direction of rotation cannot be the same unless an idler gear is installed. In that case, the centers of the input and output shafts cannot be too close. Rotating the input link clockwise causes the output to follow in a clockwise direction. For any set of link proportions, the distance between the shafts determines the gain in angle multiplication.

The video shows case when the green link rotates 90 deg., the blue rotates 180 deg.

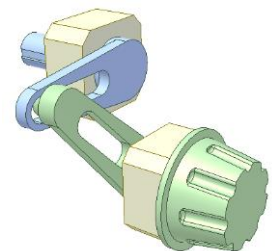

Bar mechanism for reversing rotation 1

<https://youtu.be/nwuQvjSxz0c>

Yellow, pink and violet sliders have prismatic joints with blue bar, green bar and grey fixed runway respectively.

The sliders are connected together by revolute joints.

Input: blue (or green) bar.

Output: the other bar. It turns at the same input velocity but in opposite direction.

Disadvantage: turnable angle is less than 180 deg.

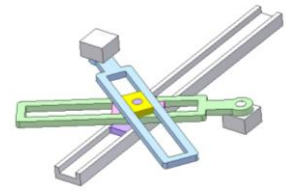

Gear rack mechanism for reversing rotation 2

<https://youtu.be/BQndfB7xTQs>

Input: pink (or blue) gear.

Output: the other gear. It turns at the same input velocity but in opposite direction.

Green runways are pivoted idly on the gears so it is easy to adjust position of the output.

It is possible to set the mechanism to get two gears rotate in the same direction: reassembly the yellow rack in such a way that its teeth are on one side.

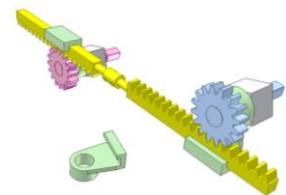

Chain mechanism for reversing rotation 1

<https://youtu.be/2KCX5VDrTeU>

Input: orange (or yellow) sprocket.

Output: the other sprocket. It turns at the same input velocity but in opposite direction.

Max turnable angle is around 180 deg. It can be larger when increasing sprocket center distance.

The blue rod should be of a cable tensioner type to ensure chain tension.

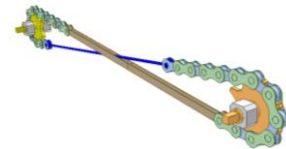

Pin rack mechanism for reversing rotation

<https://youtu.be/zXwiEyQAXOo>

Input: one of the two gears.

Output: the other gear. It turns at the same input velocity but in opposite direction.

Yellow runways are pivoted idly on the gears so it is easy to adjust position of the output.

In place of the pins a stretch of chain fixed to the rack base is a possible variant.

It is possible to set the mechanism to get two gears rotate in the same direction: let the pin rack to mesh with both two gears on one side.

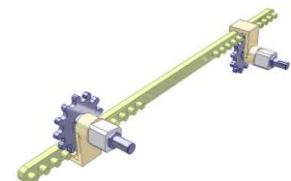

Cable drive 14

http://youtu.be/DaQR9II_YMo

Input: The brown crank having oscillating rotational motion.
The green crank has the same motion but of inverse direction.
Two yellow wheel has oscillating rotational motion of opposite direction.
Each belt (red and blue) has one end fixed to the brown crank, the other to green one.

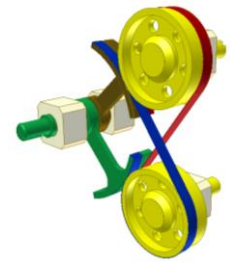

Typewriter drive

<http://www.youtube.com/watch?v=jYhkRX--2zI>

Two four-bar linkages are connected in series. The finger force of a typewriter is multiplied producing a strong hammer action at the roller from a light touch.

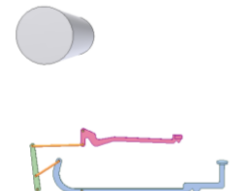

Nut-screw and bar mechanisms 1a

<http://youtu.be/gFAj1TZCLMs>

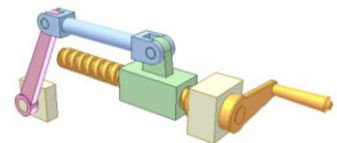

Nut-screw and bar mechanisms 1b

<http://youtu.be/asan09b1Gsc>

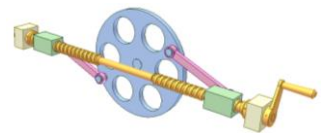

Nut-screw and bar mechanisms 1c

http://youtu.be/oA487meC_1w

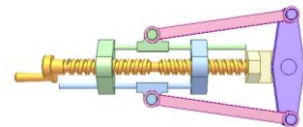

Nut-screw and bar mechanisms 2a

<http://youtu.be/xE8pSM9MIyo>



Nut-screw and bar mechanisms 2b

<http://youtu.be/FVahqIFr51c>

Device for emptying a tank.

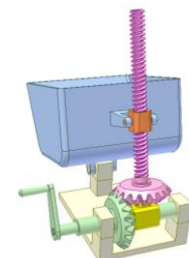

Nut-screw and bar mechanisms 3

<http://youtu.be/o4N6iviUdgs>



Nut-screw and bar mechanisms 7

<http://youtu.be/fBJr9DMLQtQ>

Belt tensioner.

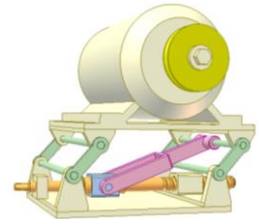

Converting rotation into coaxial rotary oscillation

<https://youtu.be/3nMy6ZiES8A>

Input: gray gear of a barrel cam rotating continuously.

Output: blue crank of second barrel cam that performs rotary oscillation with pauses.

Input and output are coaxial.

Pink slider moves along a groove of the base. Red pin fixed to the slider moves in both slots of the barrel cams.

Gray cam makes the slider reciprocate linearly.

The slider makes the crank oscillate.

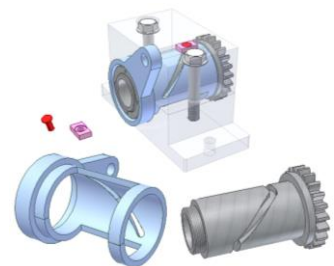

Increasing oscillating angle by helical joints

<https://youtu.be/QuZqRMrag0o>

Input: barrel cam of blue lever.

Output: green barrel cam to which a green bucket is fixed.

Pink slider moves in straight groove of the base. The slider pin (in red) moves in helical slots of the two cams.

When the blue lever turns 70 deg., the bucket turns 160 deg.

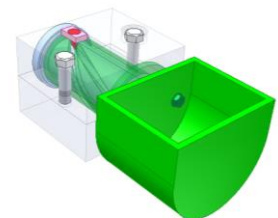

Increasing oscillating angle by gear drives

<https://youtu.be/QuZqRMrag0o>

Input: cyan lever to which a blue gear is fixed.

Output: green gear to which a green bucket is fixed.

When the cyan lever turns 70 deg., the bucket turns 160 deg.

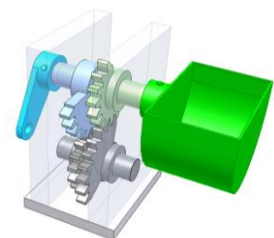

Increasing oscillating angle by coulisse linkage

<https://youtu.be/o5dzfKdz4m0>

Input: cyan lever to which a blue crank is fixed.

Output: green crank to which a green bucket is fixed.

Pins of the two cranks moves in straight slots of pink bar.

When the cyan lever turns 70 deg., the bucket turns 160 deg.

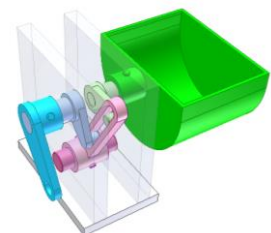

5. Converting continuous rotation into linear motion

5.1. Bars

Slider-crank mechanism 1

<http://www.youtube.com/watch?v=OltIA-RI86A>

Rotary joint between the conrod (in orange) and the slider (in green) is larger than the conrod length.

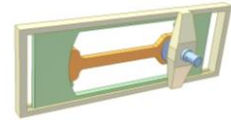

Slider-crank mechanism 2

<http://www.youtube.com/watch?v=0nnS8ycMVNA>

Rotary joint between the conrod (in violet) and the crank (in blue) is larger than the conrod length.

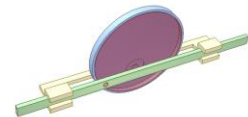

Slider-crank mechanism 3

<http://www.youtube.com/watch?v=aJx1iQHzB6E>

Rotary joint between the conrod (in pink) and the slider (in green) is larger than the conrod length.

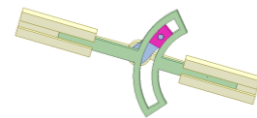

Slider-crank mechanism 4

<https://youtu.be/67dxX-FMsH4>

Blue conrod is inside green slider.

The conrod-slider revolute joint is on the right.

The conrod-slider contact on the left is for form closing of the said joint.

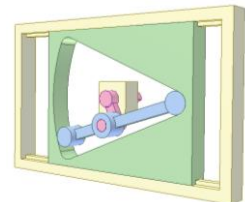

Slider-crank mechanism 5

<https://youtu.be/qHgkESpDMeA>

Orange conrod is inside green slider.

Two revolute joints of the conrod are large than their center distance.

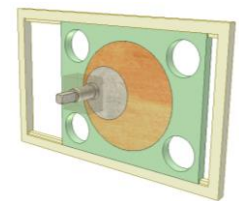

Slider-crank mechanism 6

<http://youtu.be/Dv6m1AFejJ4>

Blue piston-rod is prolonged and works in a guide, which is in line with the center of yellow fixed cylinder. The lower part of green connecting-rod is forked to permit the upper part of the piston-rod to pass between. So the piston is guided very well.



Slider-crank mechanism for long stroke 3

<https://youtu.be/56fJjeeEo38>

Crank length: a. Conrod length: b

Eccentricity of the slider crank mechanism: e

(distance between rotary axis of the crank and line tracing by a point on axis of the slider pin)

Key factor for this mechanism: $e = b - a$

Stroke length of the slider: $L = 4 \cdot \sqrt{a \cdot b}$

So theoretically, with a given crank of constant radius a, it is possible to get the stroke length L as long as desired by increasing the conrod length b.

If $b = a$; $L = 4a$

See: <http://www.youtube.com/watch?v=Ug7TK4YTRIY>

Here: $a = 30$; $b = 60$; $L = 169.7$

Working cycle corresponds with two revolutions of the crank. Green curve is locus of the conrod middle point. Dead position: when crank and conrod are in line.

This mechanism is numbered as 175 in the book "507 mechanical movements", 1868.

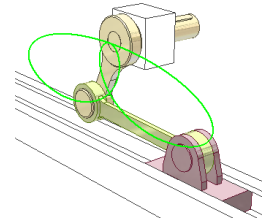

Rolling slider

https://youtu.be/v_gt3OtdW7w

The rollers are arranged in such a way that the middle ones contact lower surfaces of the runway, the others contact the upper surfaces.

There is no sliding between the rollers and runway. Compare with the case when the rollers arranged in line contact both lower and upper surfaces.

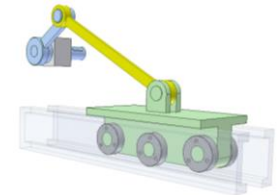

Slider of added rollers

https://youtu.be/AxWRh_1QTVc

Yellow conrod is connected to green slider via a second conrod (in violet). The latter has revolute joint with the green slider.

Orange rollers are pivoted on axis of the revolute joint between yellow and violet conrods.

Roller diameter is slightly smaller than the runway height to ensure that the contact between roller and the runway are only on one side of the rollers (upper or lower). Thus mainly rolling friction is applied to the runway.

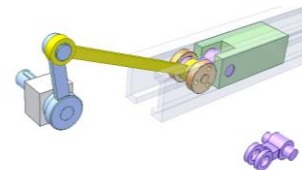

Bar linkage of constant speed slider

<https://youtu.be/i5me5yPRU78>

It is created by serial connection of 4-bar linkage (pink, yellow and blue) and slider crank mechanism (blue, green and red).

Input: pink crank rotating regularly.

Red slider has nearly constant speed when going forwards. Red line of the graph shows relation of the slider speed and time.

This video was made based on:

<https://www.youtube.com/watch?v=SSVBegtnaAw>

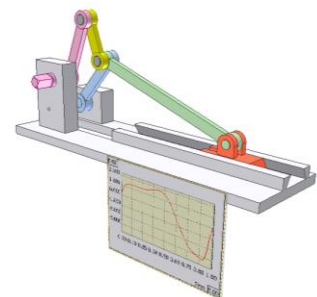

Slider crank mechanism of equal crank and conrod length 1

<https://youtu.be/oGIPbZPI2bQ>

The mechanism gives long stroke length of orange slider $L = 4R$.

R is crank radius (in yellow) and length of conrod (in green).

If the crank is driving the mechanism faces unstable positions when the crank rotary axis and the slider pivot are in line.

To fix this problem here the mechanism is added with two gears of equal tooth number to make the conrod driving.

Pink gear is the input, green gear is fixed to the conrod.

A working cycle corresponds 3 revolutions of the pink gear.

It is possible to use chain drive instead of the two gears in case the crank radius is too long.

If tooth numbers of the two gears are not the same, the mechanism works with different working cycle time.

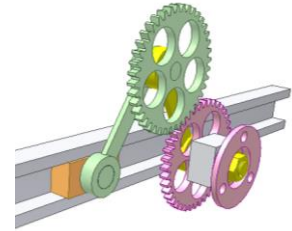

Slider crank mechanism of equal crank and conrod length 2

<https://youtu.be/4QBw1wef438>

The mechanism gives long stroke length of orange slider $L = 4R$.

R is crank radius (in pink) and length of conrod (in green).

If the crank is driving, the mechanism faces unstable positions when the crank rotary axis and the slider pivot are in line.

To fix this problem here the mechanism is added with a chain drive to make the conrod driving. The yellow transparent part represents a chain.

Grey sprocket of Z_2 teeth is stationary. Green sprocket of Z_1 teeth is fixed to the green conrod. $Z_2 = 2 \cdot Z_1$.

So the mechanism has two driving links: the crank and the conrod that rotate synchronically.

If lengths of the crank and the conrod are different, the mechanism does not work.

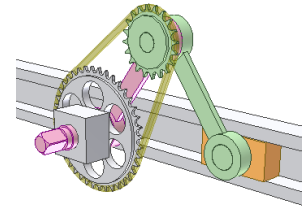

Slider crank mechanism of equal crank and conrod length 3

<https://youtu.be/1TQ8ISoJkmc>

The mechanism gives long stroke length of blue slider $L = 4R$.

R is crank radius (in yellow) and length of conrod (in green).

If the crank is driving, the mechanism faces unstable positions when the crank rotary axis and the slider pivot are in line.

To fix this problem here the green conrod is driving thanks a motor (in blue) fixed to the slider.

If lengths of the crank and the conrod are different, the mechanism does not work.

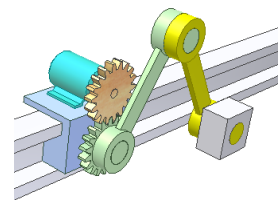

Slider crank mechanism of large pressure angle 1

<https://youtu.be/uQHmOk4i2HU>

R is crank radius (in yellow)

L is length of conrod (in green).

L is a little larger than R: $L = 1.0125R$

If the crank is driving, the mechanism is hard to move because of large pressure angle (between the conrod and moving direction of the slider).

To fix this problem here the mechanism is added with two gears to make the conrod driving.

Pink gear of tooth number $Z1$ is the input.

Green gear of tooth number $Z2$ is fixed to the conrod.

Here $K = Z1/Z2 = 1$

A working cycle (W) corresponds 2 revolutions of the pink gear.

The crank rotates irregularly.

Advantage: orange slider rests at its right position rather long, around $0.2W$.

For other value of K, W will be changed.

It is possible to use chain drive instead of the two gears in case the crank radius is too long.

The mechanism needs to be verified in practice.

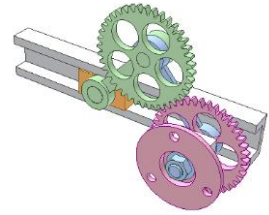

Mechanism for adjusting crank radius 1a

<http://youtu.be/xAMjCiWGpws>

Radius of green crank is adjusted by turning pink gear after retracting the orange pin. The red nut at the back of the pin gear is for clamping the gear after adjustment.

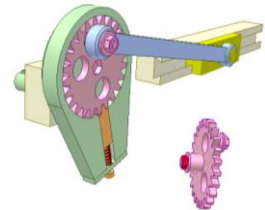

Mechanism for adjusting crank radius 2a

<http://youtu.be/MCoOX06KnGo>

Input: blue shaft.

Output: green slider linearly reciprocating.

The video shows the changing stroke length of the green slider by turning pink screw to change crank radius.

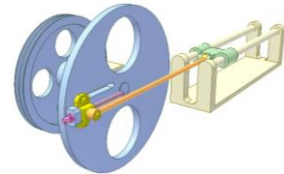

Mechanism for adjusting crank radius 2b

<http://youtu.be/gpLN-fB08Vs>

Input: beige disk carrying red slider-pivot.

Output: green slider linearly reciprocating.

Turn yellow bevel gear to change position of the red slider-pivot on the disk (to adjust crank radius) to get various output strokes.

Device for fixing the red slider-pivot to the disk after adjusting is not shown.

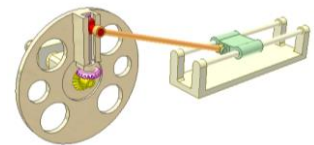

Mechanism for adjusting crank radius 3a

<http://youtu.be/65OM2dezTBs>

Input: blue shaft.

Output: green slider linearly reciprocating.

The video shows the changing stroke length of the green slider by turning violet screw to change crank radius (distance between blue shaft axis and orange pivot axis).

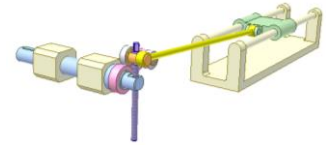

Mechanism for adjusting crank radius 1b

<http://youtu.be/jLMNtKjM2CE>

Input: pink eccentric shaft.

Output: blue slider linearly reciprocating.

Yellow eccentric bush is idly mounted on the eccentric of the pink shaft. Turn the yellow bush to get various angular positions in relation with the pink shaft, corresponding various stroke lengths of the output.

The grey gear disk and violet nut are for fixing the yellow bush and the pink crank together after adjustment.

Stroke position can be adjusted thanks to screw and round nut of the green conrod.

The video shows the process to reduce stroke length from max value to shorter one.

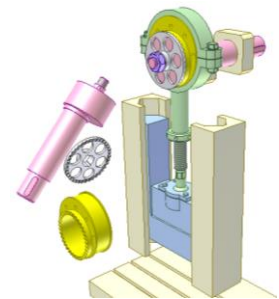

Eccentricity adjustment 1

https://youtu.be/nHW425X_1w8

Move green eccentric in relation with blue disk to get various eccentricities. The joint between them is prismatic (two pins and two straight slots).

Green bolts is for fixing the eccentric with the disk after adjustment.

The video shows the adjustment process from zero to max value.

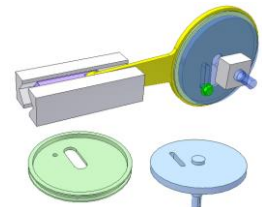

Eccentricity adjustment 2

<https://youtu.be/uB9jHa2QpyQ>

It is an improvement of "Eccentricity adjustment 1" for heavy duty mechanism.

Turn pink pinion to move green eccentric in relation with blue disk to get various eccentricities.

A rack is fixed to green eccentric that has prismatic joint with blue driving disk.

Two bolts are for fixing the eccentric with the disk after adjustment.

The video shows the adjustment process from zero to max value.

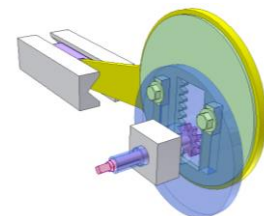

Eccentricity adjustment 3

<https://youtu.be/3Sol8hMB30Y>

Turn pink pinion to move green eccentric in relation with blue disk to get various eccentricities.

An internal gear sector is fixed to green eccentric that has revolution joint with blue driving disk.

The nut is for fixing the eccentric with the disk after adjustment.

The video shows the adjustment process from zero to max value.

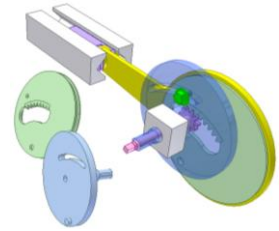

Adjustable eccentric cam

<https://youtu.be/La2lv3FHefc>

Input: blue shaft.

Turn pink screw to adjust the stroke length of green follower.

The video shows the process of adjustment from 2 mm to 10 mm of the stroke length.

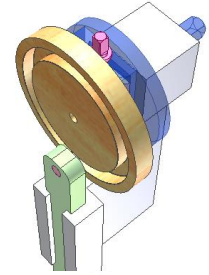

Adjusting crank radius without stopping it 1

<https://youtu.be/VF6iT9WWF4A>

It's an application of

<https://youtu.be/EhBBxoh0kuQ>

Turn pink screw to adjust the eccentric of orange pivot (crank radius). The pink screw moves violet nut. The latter moves blue screw. Axial displacement of the blue screw makes green gear rotate and move orange rack of orange cross slider carrying the orange pivot.

The orange slider move in runway of face plate (in popcorn color) of input pulley.

The video shows how to adjust the eccentric from 0 to max value and vice versa.

The adjustment can be performed even without stopping the input pulley as shown in last two scenes of the video.

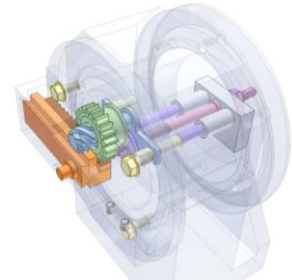

Adjusting crank radius without stopping it 2

<https://youtu.be/dBakj6Ze3h8>

When orange handle is kept immobile by red screw, the rotation of input disk of belt pulley (in popcorn color) does not make brown screw rotate thus pivot (in pink) is kept immobile in runway of the disk. The crank radius is not changed as show in third scene of the video.

That is ensured by:

1. Bevel gear differential of violet carrier.
2. Spur gear train from yellow gear to violet one. Its transmission ratio is 2. Tooth numbers of bevel gears are the same.

Turn orange handle of orange bevel gear to change position of pink pivot (thus to adjust the crank radius) as shown in last scene of the video. Speeds of the handle and the brown screw are the same. It would be better if a revolution counter for the handle is added to indicate position of the pink pivot (the crank radius) while adjusting.

The crank radius adjustment can be performed without stopping the input pulley as shown in two first scenes of the video.

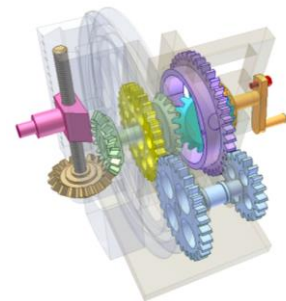

Slider-crank mechanism for adjusting stroke position 1

<http://youtu.be/JMIEaNwuMEk>

Input: pink crankshaft.

Output: blue slider linearly reciprocating.

Turn yellow screw to alter length of the assembly conrod (yellow screw, green bush and violet nut) for adjusting stroke position of the blue slider.

The violet nut is for fixing the conrod members together after adjusting.

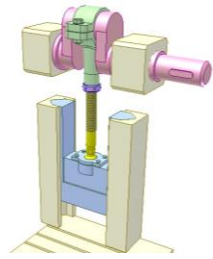

Slider-crank mechanism for adjusting stroke position 2

<http://youtu.be/6iNz9Q6-0oc>

Input: pink crankshaft.

Output: yellow slider linearly reciprocating.

Turn red screw to alter position between the yellow slider and the brown inner slider for adjusting stroke position of the yellow slider.

The violet nut is for fixing the two sliders together after adjusting.

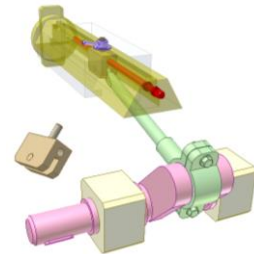

Slider-crank mechanism having a pause at both ends of stroke 2

<http://www.youtube.com/watch?v=TTbWZcg1N6c>

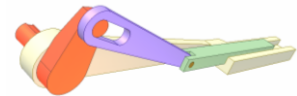

Slider crank mechanism with eccentric

http://youtu.be/zR_i_DdRI0

Input is the orange crank.

Turn the blue eccentric and fix it to get various positions of the slider course.

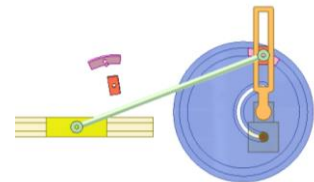

Slider crank mechanism with face groove cam

<http://youtu.be/RFaLPuKkyAE>

Input is the orange crank.

The blue cam is fixed. The cam profile has two portions, radii of which are equal to the length of the green connecting rod. Thus the yellow slider reciprocates with dwells at both ends of its course.

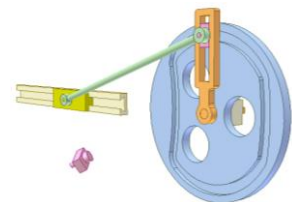

Slider-crank mechanism having a pause at both ends of stroke 3

<http://youtu.be/s0Lx-6c9JYk>

Input: pink crank.

Output: green slider that linearly reciprocates with dwell at both ends of stroke.

Yellow slider moves along the dovetail shaped groove of the green slider.

Violet screws are for adjusting positions of orange sliders to get various stroke lengths of the green slider.

Ball spring devices for positioning the green slider at its end positions are not shown.

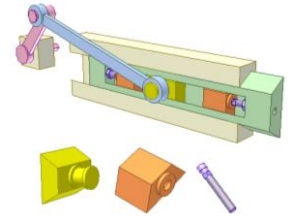

Slider-crank mechanism with dwells

<https://youtu.be/1RASk3s5axg>

Input: pink shaft rotating continuously.

Output: yellow slider linearly reciprocating with dwells.

The dwells are created due to orange teeth-uncompleted gears.

There are two working modes: the dwells take place at both ends (first part of this video) or at one end (second part) of the slider stroke.

Use blue shifter to switch between two modes (moving the teeth-uncompleted gear block).

It is an application of mechanism shown at:

<https://youtu.be/8INxCUpZH8k>

This gear drive can be called as the gear box for interrupted rotation.

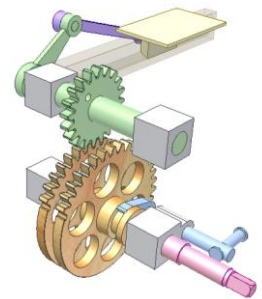

Conrod of three sliders mechanism

<https://youtu.be/mLUA2hcNky0>

Input: blue cross slot disk. The slots are eccentric.

Output: orange slider of complicated motion rule.

If the slot center lines and the disk rotation axis are concurrent, the mechanism works as a regular slider-crank mechanism with crank radius $R = 1/2L$.

L: center distance of two pink sliders.

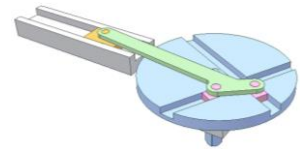

Slider-crank mechanism with added double crank

<http://www.youtube.com/watch?v=fBS00ak300U>

The slider's stroke length is nearly 4 times of the red crank length.

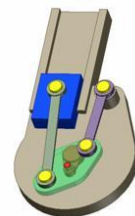

Face gear 15

<http://youtu.be/2Y8jBdF8U-4>

The face gear is placed eccentrically to the shaft, therefore the relative radius changes. Due to variable circular motion of the face gear the pink slider's left to right motion is faster than right to left one.

The face width of the face gear must be small to enable gear meshing.



Slider-crank mechanism with added double crank

<http://www.youtube.com/watch?v=Glm8FxmNI>

The slider's stroke length is 4 times of the red crank length.

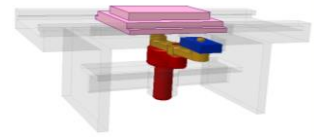

Dwell Slider Mechanism 2

<http://youtu.be/mq3jsfBg2OI>

The input blue crank carries the yellow pawl which engages two slots of the orange disk to make the violet slider reciprocate with dwell in the middle of its stroke. The pink cam controls the pawl by pushing the pawl pin.

1 working cycle of the mechanism corresponds 2 revolutions of the blue input crank.

Angle between the two slots on the orange disk is not 180 deg.

The device (a ball plunger) to keep the slider immobile during its dwell is not shown.

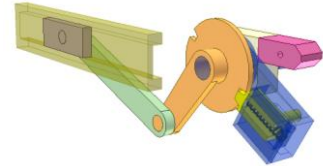

Inverse parallelogram mechanism 15

<http://youtu.be/QmEalhjP8f0>

Input: pink crank rotating regularly.

Output: orange slider.

Combination of inverse parallelogram mechanism and slider crank one gives the output an almost regular velocity during its forward stroke.

Added gears help the inverse parallelogram mechanism overcome unstable positions.

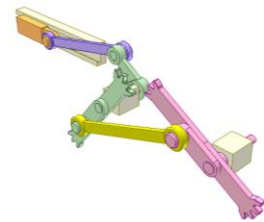

Slider-twin crank mechanism having a pause at both ends of stroke

<http://www.youtube.com/watch?v=lkwYHs2Lba0>

Angle between two cranks is 90 degrees.

Crank length = 8, Conrod length = 21

T-shape link is an isosceles triangle. Length of the bottom side = 21. Length of altitude to the bottom side = 18

Eccentricity = 0

The dwell period at each end of stroke is around 10% of cycle time. The graph shows slider position.

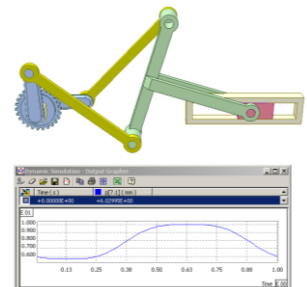

Dwell slider mechanism 4

<http://youtu.be/YJhMMj3u73M>

The green crank is driving. The yellow output slider reciprocates with dwell at its stroke ends.

The stroke length and dwell time of the out put slider depend on positions of the blue adjustable stoppers. For max stroke length: distance between the stoppers equals to the pink slider length.

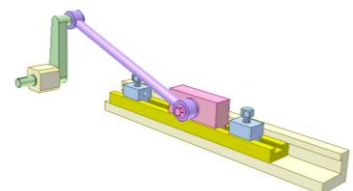

One way linear clutch 1

<http://youtu.be/beMNGEcYTvc>

The yellow slider reciprocates but the pink rack moves to the left only.

To adjust the blue screws positions for the move to the right.

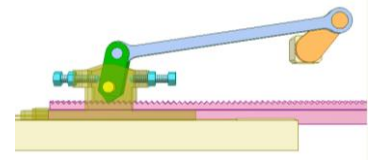

Double slider crank mechanism

<http://youtu.be/r92k9A3sgrg>

The pink slider moves on the yellow one. The latter moves on stationary runway. Both sliders are driven from the red driving crank. The stroke of the yellow slider is longer than the one of the pink slider. Their dead points are a little different in term of phase.

This mechanism is applied in wire bending machines.

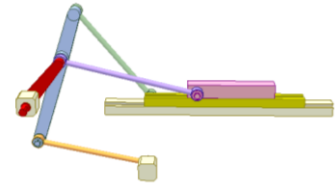

Shaper with Coulisse mechanism 1

<http://www.youtube.com/watch?v=hZEDBbc-JMo>

Reciprocating motion having working stroke slower than return one.

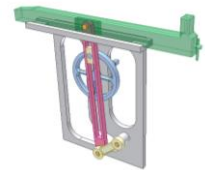

Shaper with Coulisse mechanism 2

<http://www.youtube.com/watch?v=5cb7D9pLcq4>

Reciprocating motion having working stroke slower than return one.

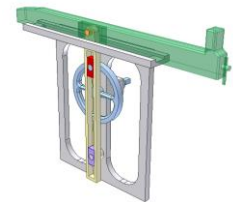

Shaper with Coulisse mechanism 3

<http://www.youtube.com/watch?v=lcbya3378qE>

Reciprocating motion having working stroke slower than return one.

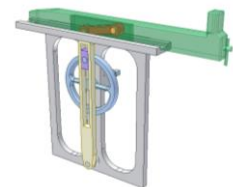

Mechanism for increasing stroke length 3

<http://youtu.be/ITYKyqWmD9Q>

Input: orange crank rotating regularly.

Output: grey bar linearly reciprocating with adjustable stroke length.

Yellow lower slider has revolution joint with pink slider.

Adjust position of the pink slider on the fixed runway to get various stroke lengths of the output.

The video shows stroke length reducing process when the mechanism is running.

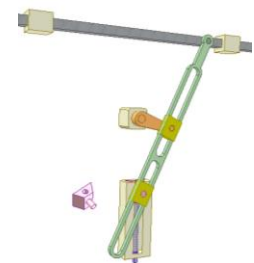

Coulisse mechanism of curved slot

<http://youtu.be/J7BHvTM7gcA>

The circular arc on the oscillating link permits the link to reach a dwell during the right position of the output slider.

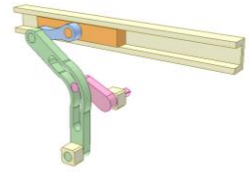

Coulisse mechanism 4

<http://www.youtube.com/watch?v=zPh2EzvuVNc>

Combination of a coulisse mechanism and a slider-crank mechanism.

Reciprocating motion has working stroke slower than return one.

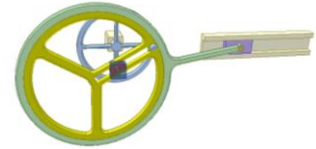

Coulisse mechanism 5

<http://www.youtube.com/watch?v=yha4fgFOP0k>

Combination of a coulisse mechanism and a slider-crank mechanism.

The green wheel has complicated rotation.

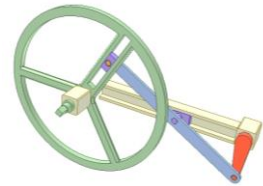

Sine mechanism 1

<http://youtu.be/VALy2PIBuM4>

Relation between the rotation angle of the crank and the position of the green slider is a sinus function.

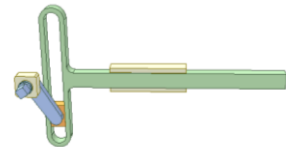

Sine mechanism 2

<http://youtu.be/5GXZ2AzRJqE>

Sine mechanism of inclined slot has longer stroke length in comparison with the sine mechanism of uninclined slot.

The rotation angles of the crank to reach the extremities of the slider are different too.

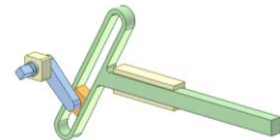

Sine mechanism of curved slot 1

<http://youtu.be/VPZO7txZIZU>

The circular arc on the reciprocating link permits the link to reach a dwell during its right position.

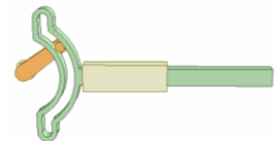

Sine mechanism of curved slot 2

<http://youtu.be/BpU7YqW2eH4>

The circular arc on the reciprocating link permits the link to reach dwell at its left position.

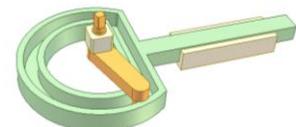

Sine mechanism of curved slot 3

<http://youtu.be/Jb03Ru6E-UA>

The circular arc on the reciprocating link permits the link to reach dwell at its center position.

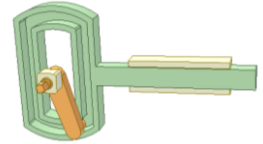

Sine mechanism 4

<http://youtu.be/O4qYJ77Zbq0>

Rotate the pink screw to adjust stroke of the blue slider.

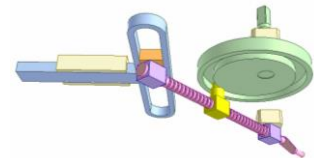

Sine mechanism 3: Press

<http://youtu.be/TZR7ccjy9VQ>

This kind of press can give 2500 ton forging force, 40 strokes per minute.

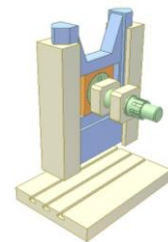

Cam and sine mechanism 2

<http://youtu.be/CufL-cYm6eM>

The green slider reciprocates with dwells at both ends of its stroke. The orange rhomb-shaped guide helps the yellow crank's pin enter into both round slots alternately. A spring forcing the guides against the red pin clockwise is not shown.

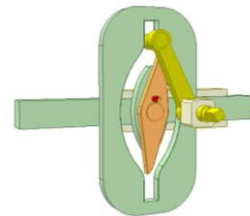

One way clutch 7: Press

<http://youtu.be/pOYoSy33Lg4>

The yellow input shaft carrying the red pawl rotates continuously anti-clockwise. The violet disk (ratchet wheel) has a pin that slides in a slot of the yellow slider.

The slider goes up by the ratchet mechanism action but goes down by its weight (when the slider moves faster than the input shaft) so that the motion cycle time is reduced. For this prototype, 4 revolutions of the input shaft correspond 7 double strokes of the slider.

The ratchet mechanism can be replaced by a roller clutch of video:

<http://youtu.be/umaTetoaAao>

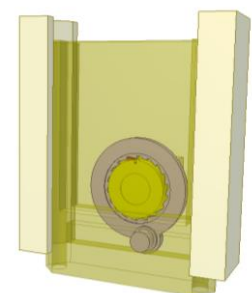

Geneva disk of linear motion

<https://youtu.be/6MIX556XF1o>

Input: green double crank of radius R.

Output: yellow 4-slot slider of smooth motion.

Slider stroke length: $L = 4R \cdot \cos(45)$.

In fact it is an embodiment of sine mechanism (Scotch yoke) of inclined slot:

<http://youtu.be/5GXZ2AzRjgE>

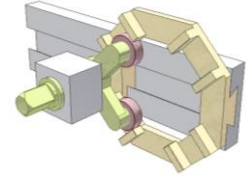

Tangent mechanism

<http://youtu.be/DymKkYp-W-A>

Relation between the rotation angle of the blue crank and the position of the green slider is a tangent function. No link can have full rotation

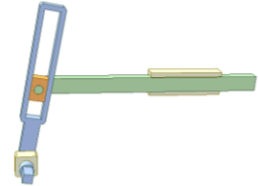

Tangent mechanism 2

<https://youtu.be/ScduZh40kXI>

It is a structural embodiment of the mechanism shown by the sketch.

Orange input part: 8

Blue disk: 7

Green slider: 3

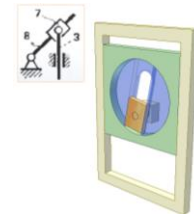

Tangent mechanism of curved slot

<http://youtu.be/0wMIH4x0OKo>

Combination of 4R mechanism and tangent mechanism. The latter has curved slot so the slider has a dwell in the middle of its stroke.

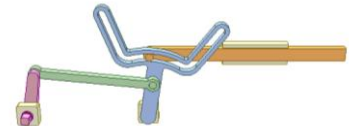

Ellipse mechanism 1a

<http://youtu.be/gnJSN0T4AUw>

Ellipse mechanism with non 90 deg. angle between sliding directions.

Position of joint between the blue crank and the green connecting rod and radius of the blue crank must be selected based on the description in

<http://www.youtube.com/watch?v=8WCee-fP9rg>

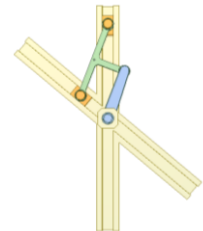

Ellipse mechanism 1b

<http://youtu.be/0h0ofdDauQE>

Ellipse mechanism with non 90 deg. angle between sliding directions.

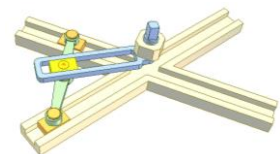

Double coulisse mechanism 1

http://youtu.be/m2_HCp8DmNU

Input is pink crank of constant velocity.

Output is green slider of forwards slow constant velocity motion to the left and quick return. The mechanism can be applied for shapers (machine tools)



Slider and parallelogram mechanism 3

<http://youtu.be/f47Oioat0pc>

Two cranks and yellow conrod create a parallelogram mechanism.

Input: pink crank rotating continuously.

Output: green slider performing linear harmonic oscillation like in sine mechanism. Prismatic joint between the conrod and green slider ensures no offset for force applied to the slider (the offset is considerable in case of sine mechanism).

Blue conrod jointing two eccentrics of the cranks is for overcoming dead positions.

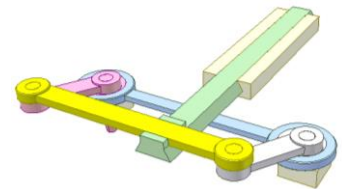

Linear reciprocating motion of long dwell

<https://youtu.be/xXlvdF5m1Ok>

Input: pink crank rotating continuously.

Output: yellow slider that has linear reciprocating motion of long dwell at its rightmost position.

Dwell time is more than 1/2 of working period.

Length of pink crank: a

Length of blue bar: $4a$

Distances between stationary bearings: $1.5a$.

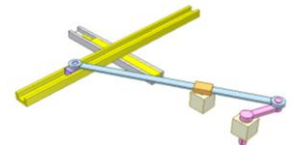

Slider crank mechanism with elbow-lever 1

<http://youtu.be/QHqbYz8IBTI>

Input: orange crank having a stud.

Output: pink slider linearly reciprocating with dwell at its leftest position.

Blue elbow-lever returns to its initial position thanks to violet coil spring.

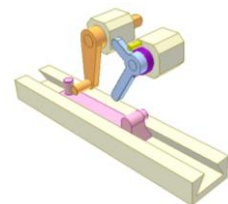

Slider crank mechanism with elbow-lever 2

http://youtu.be/fOO_7RDauIM

Input: orange crank having two studs.

Output: pink slider linearly reciprocating.

Blue elbow-lever returns to its initial position thanks to the gravity.

In one revolution of the input the slider performs two double strokes.

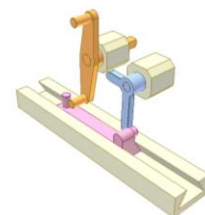

Dwell Slider Mechanism 3

<http://youtu.be/-QT0RL93ST4>

The green twin crank rotates with slow speed. The blue slider reciprocates with quick return and dwells at its end positions. The slider and the yellow pawl return by their weight or by springs force (not shown). Angle between the levers of the twin crank decides dwell time.

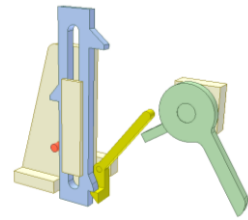

Spatial slider crank mechanism 1

<http://www.youtube.com/watch?v=qAGZCB3vZDI>

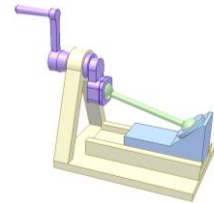

Spatial slider crank mechanism 2

<http://www.youtube.com/watch?v=PM--PK5ROkg>

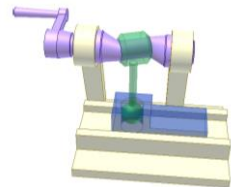

Spatial slider crank mechanism 3

<http://www.youtube.com/watch?v=oqtN3Zrf9Nk>

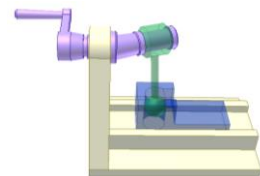

Spatial slider crank mechanism 4

<http://www.youtube.com/watch?v=bBBuLt0Vz3k>

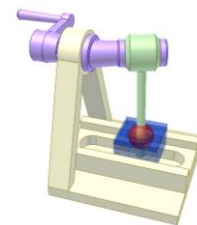

Spatial slider crank mechanism 5

<http://www.youtube.com/watch?v=sc-qsmidxVw>

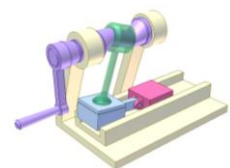

In-line reciprocator

<http://youtu.be/EG7j2koS9DQ>

Input: pink shaft.

This is a simple way to convert rotary motion to reciprocating motion. Both input and output shafts are in line with each other.

The right half of the device is a spatial reciprocator. Rotating the input crank causes its link to oscillate. A second connecting link then converts that oscillation into the desired in-line output motion.

Rotary axes of the pink shaft and the orange crank, axis of revolution joint between the orange crank and violet part, axis of revolution joint between the pink shaft and grey part must be concurrent.

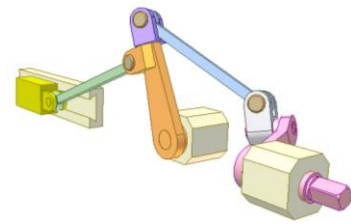

Spatial double crank slider mechanism

<https://youtu.be/5EdcZXo3FWY>

It is an application of Hobson's joint for air compressors.

Input: orange shaft.

Center of the conrod head moves along an ellipse (in green).

Advantages:

- Pressure angle on piston is small.
- Small crank radius (R) gives large displacement (L) of the piston.

$$L = 2.R/\sin(A/2)$$

A: angle between crank rotary axes.

Here A = 60 deg., L = 4R

Recirculating ball linear bearings for round shaft should be used for the green angular bar.

The mechanism has unstable positions when the planes created by axes of two joints of each crank are vertical.

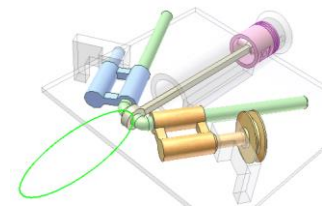

Nonstop regulatable linear oscillation 1

<https://youtu.be/QfCSXu-3C7o>

Input: blue spindle.

Output: violet blade linearly reciprocating.

Pink disk of circular groove is pivoted on the blue spindle.

Grey disk of circular groove has prismatic joint with the blue spindle.

Green conrod connects the two disks.

When the pink disk is perpendicular to the blue spindle, the violet blade is immobile. The latter comes into motion only when the pink disk is not perpendicular to the spindle.

Use orange screw to move the grey disk thus make the pink disk slanting.

First scene of the video shows regulating process from 0 to max stroke and vice versa without stopping the spindle.

This mechanism can be used for power scrapers.

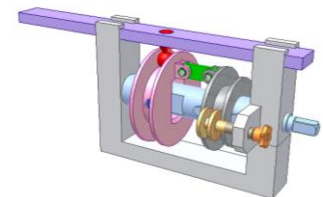

Spatial slider crank mechanism

https://youtu.be/q9c1o_q8JPI

Input: orange crank shaft rotating continuously.

Output: green slider reciprocating linearly.

Moving direction of the slider is parallel to rotary axis of the crank shaft.

It can be also used for converting linear reciprocating motion into continuous rotation.

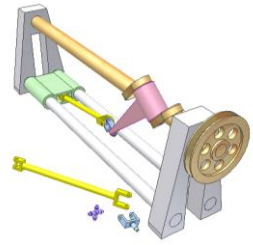

5.2. Gears

Pin rack drive 2A

<http://youtu.be/RxgB1xEv5UM>

The red pinion is input. Its shaft has an end sliding in the running track shape slot of the cyan pin rack. Because of gear forces the cyan pin rack and the yellow slider carrying the red pinion reciprocate.

The rotation from a stationary source is transmitted to the red pinion by suitable mechanisms: double Hook's joint, Oldham coupling, ...

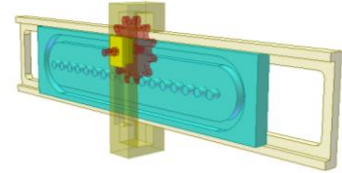

Pin rack drive 2B

http://youtu.be/itP_dBADciU

The blue pulley is input. The red pinion shaft has an end sliding in the running track shape slot of the yellow pin rack. Because of gear forces the yellow pin rack reciprocates and the cyan arm oscillates.

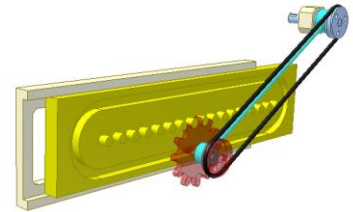

Pin rack drive 3

<http://youtu.be/ohRko--KoKc>

The green pin wheel is input. The yellow frame carrying two pink racks reciprocates with constant velocity. The dwell at the stroke ends is possible by cutting the pins.

Max stroke length = $\frac{1}{2}$ circumference of the pin wheel rolling circle.

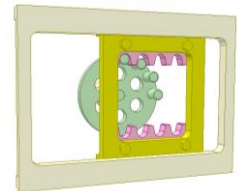

Pin rack drive 4

<http://youtu.be/q7hpu95C-2M>

The pink rotor (3-pin wheel) is driving. The blue frame (assembly of two racks of one tooth each) reciprocates with dwell.

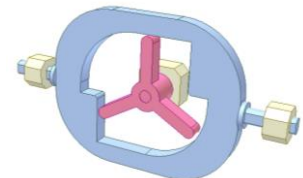

Ratchet mechanism 6

<http://youtu.be/GSABM0GR-i8>

This mechanism directly converts the continuous rotary motion of a drive shaft into the intermittent linear motion of a rack.

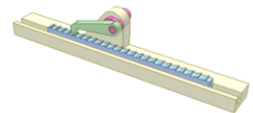

Ratchet mechanism 7

http://youtu.be/mDbLJR_bcZU

This mechanism directly converts the continuous rotary motion of a drive shaft into the intermittent linear motion of a rack.

To flop the green pawl to change the motion direction of the rack without changing the input motion direction.

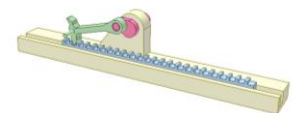

Reverse gear drive with dwell 2

<http://youtu.be/1vQCTBensQc>

The pink output gear mesh with the blue rack that reciprocates with dwell at both ends of its stroke.

The stroke length of the blue rack depends on:

- Adjustable position of the orange pin on the yellow input crank.
- Length of the bars attached to the gears.

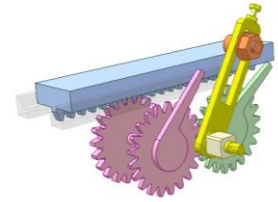

Oval gear 1a

<http://youtu.be/CL-np3ocEgc>

An input blue gear of oval shape, rotating around fixed axis, engages with a yellow gear. The latter has revolution joint with green slider.

The slider reciprocates with dwell. In case without teeth, the mechanism acts like an oval cam with possible slip.

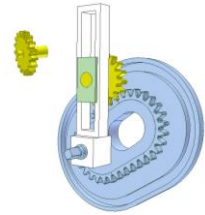

Oval gear 1b

<http://youtu.be/MNDcRZvtaTI>

An input yellow gear, rotating around fixed axis, engages with a gear of oval shape. The latter has revolution joint with green slider.

The slider reciprocates with dwell.

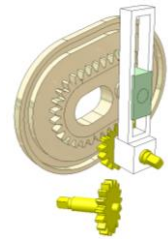

Oval gear 2a

<http://youtu.be/HhNPb9MF1Hc>

An input pink gear, rotating around movable axis of blue slider, engages with a yellow oval gear of green slider. The latter has reciprocating linear motion. Its speed is constant when the engagement takes place on straight portions of the yellow oval gear.

The input gear gets rotation from a double Cardan joint.

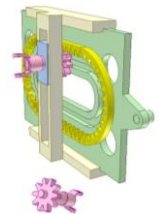

Oval gear 2b

<http://youtu.be/nigX7iAH2ss>

An yellow oval gear engages with a pink gear rotating around fixed axis.

A popcorn slider fixed to the yellow oval gear slides in groove of a green slider. The latter moves along runway of the grey base.

A pin on the pink gear face slides in an oval groove of the popcorn slider.

A pin on the right of the popcorn slider slides in the slot of orange slider. The latter moves along other runway of the grey base.

The green slider reciprocates linearly with dwells at both ends of its stroke.

The orange slider reciprocates linearly. Its speed is constant when the pink gear engages with the straight portions of the yellow oval gear.

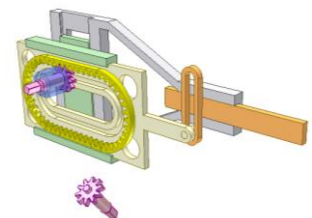

Oval gear 2c

<http://youtu.be/pNcr06qe968>

Green gear, pink large satellite gear and blue carrier create a differential planetary drive.

A pink small gear, which is fixed to the pink large satellite gear, engages with a oval gear of yellow slider. A pin on the pink small gear face slides in an oval groove of the yellow slider.

The blue carrier is driving.

The yellow slider reciprocates linearly with dwell at one end of its stroke. Its speed is constant when the pink small gear engages with the straight portions of the yellow oval gear.

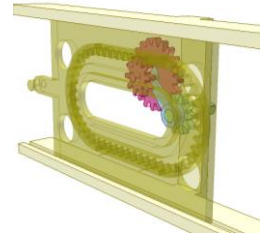

Transmission with teeth-uncompleted gears 13

<http://youtu.be/Tt06tAkyHJQ>

The orange gear is driving. The green rack reciprocates with dwell.

The forward and backward displacement may be different depending on the tooth numbers of the orange gear and stop positions of the rack and the blue gear.

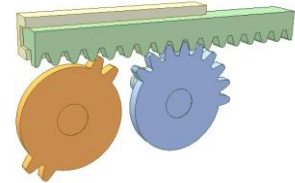

Slider-crank mechanism with satellite gear 1

<http://www.youtube.com/watch?v=cfVyZkUzzyE>

The slider's stroke length is 4 times of the crank length.

The tooth number of internal gear is two times of the one of satellite gear.

Radius of cranks = 1/2 Pitch diameter of the satellite gear.

An application of Cardano circles.

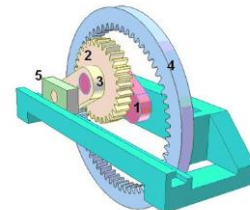

Regulatable Slider-crank mechanism with satellite gear 1

http://www.youtube.com/watch?v=3q3Ke_1YmpM

The tooth number of internal gear is two times of the one of satellite gear.

Radius of cranks = 1/2 Pitch diameter of the satellite gear.

The slider's stroke length can be regulated from 4 times of the crank length to 0 by rotating the internal gear from 0 to 90 degrees.

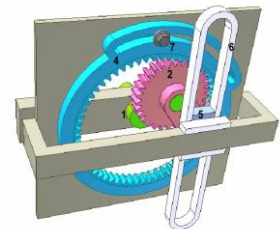

Regulatable slider-crank mechanism with satellite gear 2

<http://youtu.be/5cbfFIIPENI>

Pitch diameter of yellow satellite gear = 1/2 Pitch diameter of blue internal gear. Their rolling circles are Cardano ones.

Radius of cranks (pink and yellow) = 1/2 Pitch diameter of the satellite gear.

The green slider's stroke length can be regulated from 0 to 4 times of the crank radius by turning the internal gear via orange worm from 0 to 90 degrees.

The video shows regulating process: blue gear turns from 0 to 30 deg. for medium stroke then from 30 to 90 deg. for max stroke.

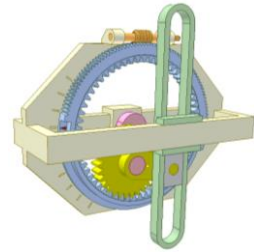

Rotation to translation mechanism 1

http://www.youtube.com/watch?v=wtn_T-WMDR4

Spur gears have eccentric shafts. The eccentricity is e .

The slider's stroke length = $4e$.

Yellow plates have rotary translational motion

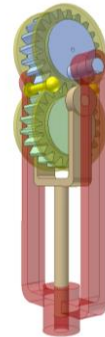

Rotation to translation mechanism 2

http://www.youtube.com/watch?v=kOyRtiDRZ_o

The spur gears and the round cams have eccentric shafts.

The eccentricity is e .

The lifting height of the working desk = $4e$.

The cams bear lifting forces.

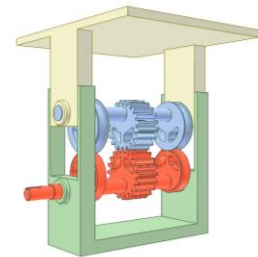

Two-worm drive 4

<https://youtu.be/pR9qItSajz4>

Two worms are skew at 90 deg. angle.

Threads of two worms are identical

Lead angle of the worm thread is 45 deg.

Start number of the worms: 3.

The pink worm is stationary.

Blue slider moves along popcorn runway when the green worm rotates.

$L = \pi \cdot D$

L: displacement of the blue slider in 1 rev. of the green worm.

D: diameter of rolling circle of the green worm.

This mechanism is a replacement for gear-rack mechanism when making the rack is not wanted.

Disadvantage: low efficiency.

Reduce lead angle of the pink worm for higher efficiency. In that case the green worm becomes a helical gear. See:

<https://youtu.be/7Fh2OVpHIO4>

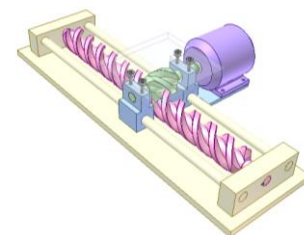

Worm gear drive 1

<https://youtu.be/7Fh2OVpHIO4>

Axes of orange gear and blue worm are skew at 90 deg. angle.

Start number of the stationary worm: 1.

Tooth number of the gear: 3.

Green slider moves along popcorn runway when the orange gear rotates.

$$L = \pi \cdot D$$

L: displacement of the green slider in 1 rev. of the gear.

D: diameter of rolling circle of the gear.

This mechanism is a replacement for gear-rack mechanism when making the rack is not wanted.

It's an improvement of the mechanism shown at:

<https://youtu.be/pR9gltSajz4>

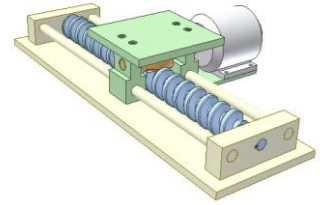

Paper folding mechanism

<https://youtu.be/VWB9VDubaxs>

Tooth number of large gear is double ones of small gears.

Blue gear and blue bar are fixed together.

Grey gear is stationary. Pink folding knife has a pin that slide in groove of glass fixed runway.

The knife performs linear reciprocating translation.

Sheet of paper (not shown) is fed into space between the knife and orange rollers, folded by the knife and pulled out by the rollers.

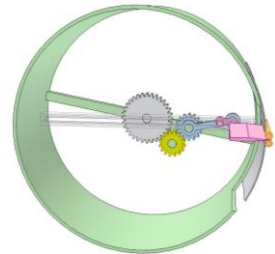

5.3. Bars and gears

Slider crank mechanism with satellite gear 2b

<http://www.youtube.com/watch?v=NctpLKvdneE>

Tooth number of yellow gear is double one of green gear.
The gears axle distance = crank length = R
The slider's stroke length = 4R

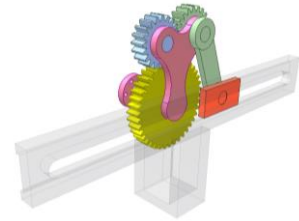

Slider crank mechanism with satellite pulley

<http://www.youtube.com/watch?v=T3pHRBBUSWo>

The diameter of the big pulley is double the one of the green pulley.
The length of each crank = R
The slider's stroke = 4R
The belt should be toothed.
It is possible to use chain drive instead of belt one.

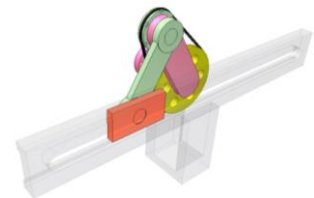

Reciprocating-table drive

http://www.youtube.com/watch?v=VzzaT_egcmc

A combination of slider-crank mechanism and rack-gear drive.
When the input crank rotates, the table will move out to a distance of 4 times the crank length.

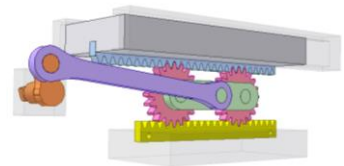

Piston without lateral force 1

<https://youtu.be/bsdlv6mCgr8>

Two identical satellite gear drives are connected together by a parallelogram mechanism.

$$Z_2 = 2 \cdot Z_1$$

Z_2 and Z_1 are tooth numbers of grey and green gears, respectively.
Lengths of pink and yellow conrods are equal to center distance of grey gears. The mechanism is set so as to get when the piston is at its highest or lowest positions, orange and green cranks are in line.
Pink piston fixed to the pink conrod vertically linearly translates and does not apply lateral force to its cylinder (not shown).

The yellow conrod mounted on eccentrics of green gears helps the parallelogram mechanism to overcome dead positions.

A mechanism of the same feature:

<http://youtu.be/muF6Y7TUJz8>

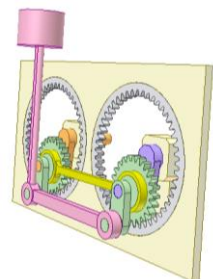

Piston without lateral force 2

<https://youtu.be/CTADdL08sLU>

Two parallelogram mechanisms are connected together by a gear drive of -1 transmission ratio.

Lengths of orange, green and violet cranks are equal.

At starting position all cranks are horizontal.

Input: orange crank.

Blue and pink conrods have circular translating motions. Their horizontal displacements are equal.

A piston is fixed to the blue conrod.

A cylinder is fixed to the pink conrod.

Stroke length of relative motion between the piston and cylinder is 4 times of the crank lengths. The piston does not apply lateral force to the cylinder.

The yellow and grey conrods mounted on eccentrics of the cranks help the parallelogram mechanisms to overcome dead positions.

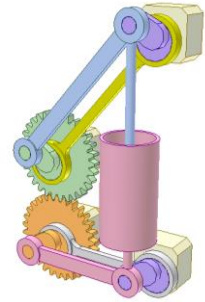

Air compressor of two coaxial pistons

<https://youtu.be/ddFowPwU0Eo>

It is a combination of two slider crank mechanisms.

Crank shaft (one in violet and one in yellow) has two cranks and is connected to two sliders (in blue and in pink) by green conrods.

Working stroke (distance between the two sliders) is increased two times (if angle between the two cranks is 180 deg.) in comparison with mechanism of one crank.

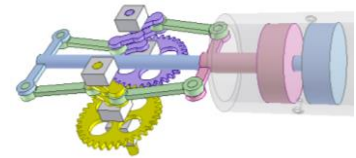

Linkage mechanism and planetary gear drive

<http://youtu.be/Pc10Hwileik>

An Artobolevski's invention: combination of planetary gear drive and double parallelogram mechanism.

Lengths of blue bars are equal.

Lengths of green bars are equal.

Lengths of orange and violet bars and center distance of green bar fixed pivots are equal.

Pitch radius of the internal gear: R

Pitch radius of the external gear: r

$R = 2r$ (Cardano circles)

Length of pink crank: r

Length of yellow crank (fixed to the external gear): r

The orange bar translates linearly. The violet bar translates circularly.

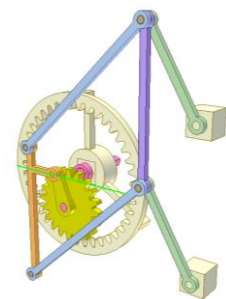

Worm drive and linkage mechanism 1

<http://youtu.be/ihXqTX91n18>

Input: green shaft rotating regularly.

Orange worm has sliding joint with the green shaft.

Output: the grey slider carrying the worm drive reciprocates.

The mechanism performs two functions: reducing speed and converting rotation into linear translation.

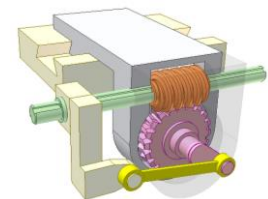

Gear and linkage mechanism 9a

<http://youtu.be/rGYGc-Qtggk>

Tooth numbers of the gears are 50 and 25.

The gears have the same distance of their pins to their rotation axes (crank radius).

The blue slider has complicated motion that depends on dimensions of the orange and violet bars, tooth numbers, crank radii and relative positions of the gear pins.



Gear and linkage mechanism 9b

http://youtu.be/Se3318gM_cg

The mechanism is symmetric in term of dimension and assembly conditions so transverse force applied to the slider is limited. The pink conrods can be directly connected to the blue slider. The green bar is added for reducing the influence of manufacturing errors.

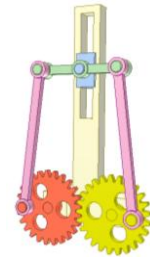

Three-gear stroke multiplier

<http://youtu.be/w2sHE327EXk>

Input: pink gear.

The rotation of the input gear causes violet conrod, attached to the machine frame to oscillate. This action produces a large-stroke reciprocating motion and fast return in the yellow output slider.

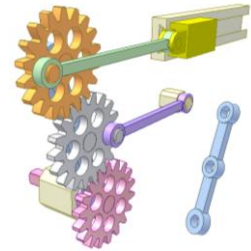

Sine mechanism 5

<http://youtu.be/dtaLfwzwcDQ>

Green gear-crank, red slider and blue slider create a sine mechanism. The green gear-crank receives rotation from pink input gear through yellow gear. The bars maintain gear engagement. The blue output slider has reciprocating linear motion. Its stroke position can be adjusted during motion by cyan screw.

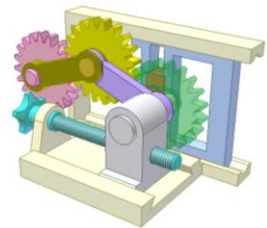

Gear and linkage mechanism 13

<http://youtu.be/i9ayXz9tEXU>

Tooth number of pink crank gear: 20

Tooth number of yellow gear: 40

The crank gear, green conrod and orange slider create a slider crank mechanism. Input is the crank gear rotating regularly.

The green conrod length = Center distance of the gear drive.

The blue slider has linear motion of complicated velocity rule.

Beside geometric dimensions of the links, its motion also depends on the position between the pin of the yellow gear and the crank gear when assembling.

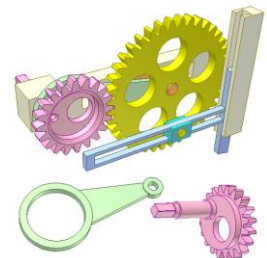

Gear and linkage mechanism 10

http://youtu.be/Pe_nNqVXAek

Pitch radius of red gear: R_1 .

Pitch radius of green gear: $R_2 = 2R_1$.

The rotation axis of the red gear is eccentric.

Its eccentricity is $E_1 = 0.125 R_1$.

Distance between rotation axis of the green gear and the pin for orange slider is $E_2 = R_1$.

Length of the yellow conrod $L = 3R_1$

The red gear, the yellow conrod and the red slider create a slider-crank mechanism.

The violet slider has linear motion with approximately uniform speed in the middle of its stroke.

Assembly condition: There is mechanism position when gear rotation axes, pin axes are on the same plane.

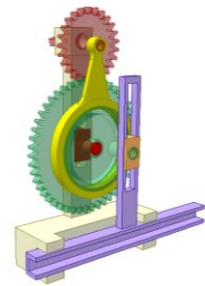

Slider-crank mechanism with gears on conrod

<http://youtu.be/doSUZ1AdKU8>

The orange gear and orange crank are fixed together.

The blue and pink gears, each rotates idly on its axle.

The orange and pink gear have the same tooth number.

The input crank rotates regularly while the blue and pink gears rotates irregularly.

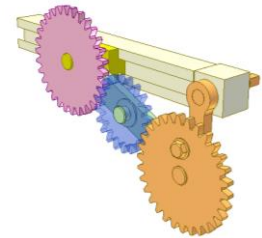

Drive for rotary printing press

<http://youtu.be/PkBikUF369E>

Input: the orange crank.

Output: the green printing bed which translates and the grey printing cylinder which rotates.

The blue gear is for additional supporting the bed.

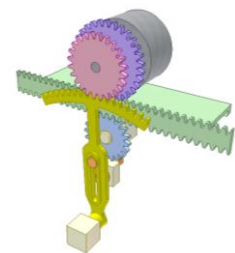

Rack pinion mechanism 5

<http://youtu.be/CBsb2Pdf2Jk>

The sinus mechanism of yellow crank and blue rack-slider makes the green shaft oscillate with amplitude of 1 revolution (see "Sinus and rack pinion drive").

The green teeth-uncompleted gear gives the pink racks dephasing reciprocating motions with pauses at both ends of stroke.

The green sector and 4 pink plates are for blocking pink output racks when pausing.

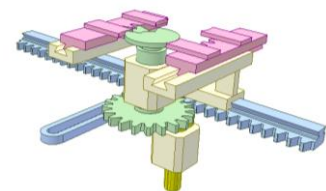

Slider-crank mechanism having a pause at the end of stroke.

<http://www.youtube.com/watch?v=ObmXPNQh1k>

The tooth number of internal gear is 3 times of the one of satellite gear.

The short crank's length is half of the long crank's one. One axle of the connecting rod draws a deltoid that consists of 3 nearly round curves. The length of the connecting rod is equal the radius of the curve.

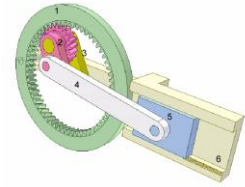

Slider-crank mechanism having a pause at the end of stroke 2.

<http://www.youtube.com/watch?v=MhFiRHWSoUc>

The tooth number of internal gear is 5 times of the one of satellite gear.

The short crank's length is half of the long crank's one. One axle of the connecting rod draws a closed curving line that consists of 5 nearly round curves. The length of the connecting rod is equal the radius of the curve.

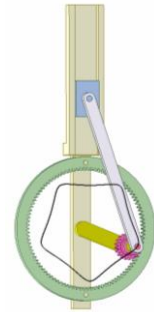

Dwell Slider Mechanism 1

<http://youtu.be/LjLH45PSf-s>

Tooth number of the fixed internal gear: 60

Tooth number of the planetary external gear: 20

Gear module: 0.5 mm

The pink curve is locus of the yellow conrod point.

Length of the yellow conrod approximates to the radius of curve segment of the pink locus. The red right slider has dwell at its right position.

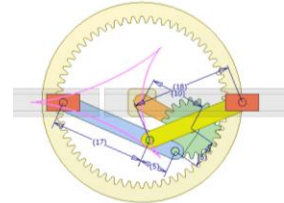

Slider-crank mechanism having a pause at both ends of stroke 1

<http://www.youtube.com/watch?v=7Ewb5C-UNfo>

Tooth number of the satellite gear Z1: 20

Tooth number of the fixed gear Z2: 100

$e/A = 0.1$

e: crank length

A: axle distance between gear Z1 and gear Z2.

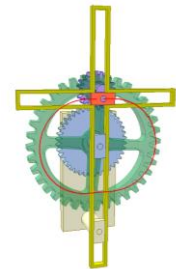

Loci in Epicyclic gearing A4b

<http://youtu.be/ft9gntesYUE>

R: pitch radius of the fixed sun gear

r: pitch radius of the planetary gear

$k = R/r = 4$

Distance between the hole axis of the orange slider and the planetary gear axis is $(11/30)r$ for getting a square of straight sides.

The blue cross has linear reciprocating motion with dwell at both stroke ends.

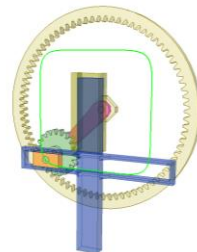

Locii in Epicyclic gearing B4

<http://youtu.be/zMOeztecSu4>

r: pitch radius of the fixed sun gear

R: pitch radius of the green planetary gear

$$k = R/r = 1.5$$

Distance between the hole axis of the orange slider and the planetary gear axis is $(124/30)r$ for getting a curve having two straight segments.

The input link is the orange disk.

The pink cross has linear reciprocating motion with dwell at both stroke ends.

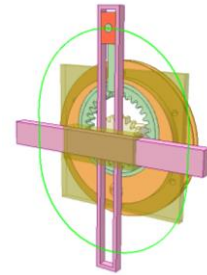

Gear crank mechanism for linear motion with dwells 1

<https://youtu.be/lZODzdY3HR0>

Input: pink crank.

R: pitch diameter of fixed gear of internal teeth.

r: pitch diameter of planetary gear (in yellow).

$$k = R/r = 6$$

Yellow crank is fixed to the yellow gear.

Yellow crank radius $R_c = 0.215r$.

Center of red slider traces green line, which is approximately an equilateral hexagon (a hypotrochoid).

Blue slider performs reciprocating motion with dwells at its end positions.

The dwell results from the portions of the green line that are perpendicular to the blue slider moving direction.

The dwell time T corresponds less than $360/k$ deg. (60 deg.) of input rotation.

For other value of T alter k and R_c .

In this video k is an even number.

If k is an odd number, the dwell can be only at one end of the slider stroke.

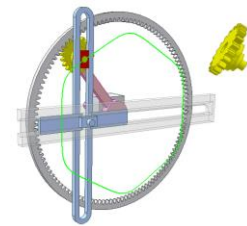

Gear crank mechanism for linear motion with dwells 2

<https://youtu.be/QrOQ8YsEjaq>

Input: pink crank.

R: pitch diameter of fixed gear of internal teeth.

r: pitch diameter of planetary gear (in yellow).

$$k = R/r = 5$$

Yellow crank is fixed to the yellow gear.

Yellow crank radius $R_c = 0.275r$.

Center of red slider traces green line, which is approximately an equilateral pentagon (a hypotrochoid).

Blue slider performs reciprocating motion with dwell at its left end position.

The dwell results from the portion of the green line that are perpendicular to the blue slider moving direction.

The dwell time T corresponds less than $360/k$ deg. (72 deg.) of input rotation.

For other value of T alter k and R_c .

In this video k is an odd number.

If k is an even number, the dwell can be at two ends of the slider stroke.

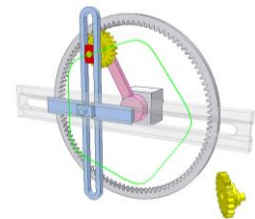

Linear translation without runway 1

<https://youtu.be/9bGxJuOk8Dw>

Input: pink gear that makes two blue cranks of two identical planetary mechanisms rotate at the same velocity and direction.

$$Z2 = 2 \cdot Z1$$

Z2 and Z1 are tooth numbers of grey and green gears, respectively.

Radius of cranks (blue and green) $R = 1/2$ pitch diameter of the green gear.

The mechanism is set so as when the blue cranks are vertical, the green cranks are vertical too.

Yellow platform has revolution joints with the green cranks. Center distance of platform joints is equal to center distance of two grey gears.

The platform is translated vertically along an absolutely straight line (no need of a runway). Its stroke length $L = 4R$.

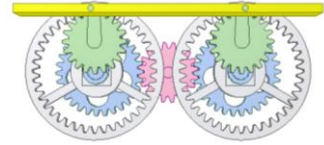

Linear translation without runway 2

<https://youtu.be/zyBiC34PQNI>

Input: pink gear that makes two blue cranks of two identical planetary mechanisms rotate at the same velocity and direction.

$$Z2 = 2 \cdot Z1$$

Z2 and Z1 are tooth numbers of grey and green gears, respectively.

The mechanism is set so as when the blue cranks are horizontal, the green cranks are horizontal too.

Yellow platform has revolution joints with the green cranks. Center distance of platform joints is equal to center distance of two grey gears.

The platform is translated horizontally along an absolutely straight line (no need of a runway). Its stroke length $L = 4R$.

R is radius of the green crank.

It is an application of the mechanism showed at:

<https://youtu.be/LHjLRiW7aYc>

It is possible to set the mechanism for translation along a slanting straight line.

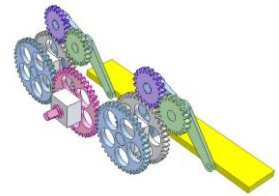

Nonstop regulatable linear oscillation 2

<https://youtu.be/OPwQAonlXB4>

It is an application of mechanism shown at

<https://youtu.be/Z2uncDpQXU>

Input: pink crank.

Output: yellow table linearly reciprocating.

If green gear is immobile, center of red slider traces a straight line.

The line direction depends on angular position of the green gear.

Use violet worm to turn the green worm wheel (fixed to the green gear) to regulate stroke of the table. The video shows regulating process from 0 to max stroke.

The process can be performed without stopping the mechanism.

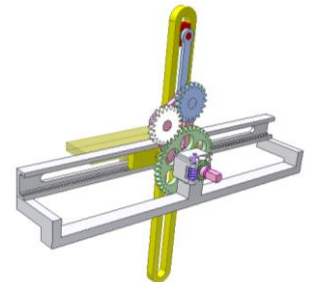

Nonstop regulatable angular oscillation 2

<https://youtu.be/zWd007xxvR4>

It is an application of mechanism shown at

https://youtu.be/_Z2uncDpQXU

Input: pink crank.

Output: green slotted bar angularly reciprocating.

If green gear is immobile, center of red slider traces a straight line.

The line direction depends on angular position of the green gear.

Use violet worm to turn the green worm wheel (fixed to the green gear) to regulate stroke of yellow slider, thus reciprocating angle of the green bar.

The video shows regulating process from 0 for reciprocating angle.

The process can be performed without stopping the mechanism.

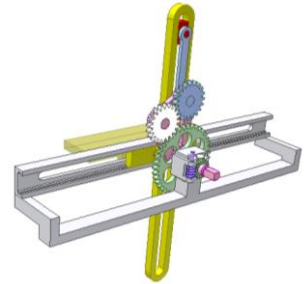

Linear translation without runway 3a

<https://youtu.be/VnS-V-cnyu4>

It is an application of Sarrus mechanism.

Input: pink crank that can rotate full revolutions.

The yellow platform is translated vertically along an absolutely straight line (no need of a runway).

Its stroke length $L = 4R$.

R : length of the cranks (in pink and blue) and bars (in green).

The mechanism has dead positions when the cranks and the bars are vertical so to overcome it the blue cranks are driven thanks to orange face gear.

When the platform crosses through the center plane (all the cranks and bars are horizontal), since the pivots on the base and the platform are aligned, the bars could rotate without the platform moving if it does not have enough momentum. Therefore, avoid stopping the platform at the center plane. If not, the mechanism can't be started.

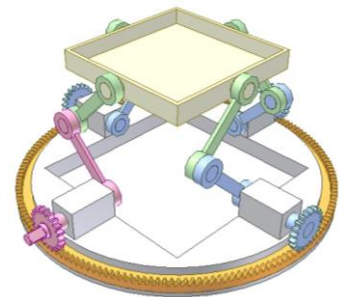

Linear translation without runway 3b

<https://youtu.be/iW9WwMPx9j8>

It is an embodiment of the mechanism shown at:

<https://youtu.be/VnS-V-cnyu4>

Input: pink shaft.

Two blue cranks are driven thanks to bevel gear drives.

The yellow platform is translated horizontally along an absolutely straight line (no need of a runway).

Its stroke length $L = 4R$.

R : length of the cranks (in blue) and bars (in green).

Two chain drives are used to help overcome unstable positions. Refer to:

<https://youtu.be/4QBw1wef438>

Grey chain wheels of Z_2 teeth are stationary.

Green sprockets of Z_1 teeth are fixed to the green bars.

$Z_2 = 2 \cdot Z_1$

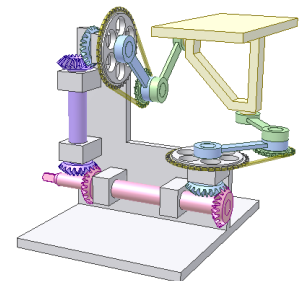

External gear slider mechanism 1

<http://youtu.be/1N7XVZPPFj8>

The yellow gear ($Z_2 = 20$ teeth) is fixed to the connecting rod.

The green gear ($Z_1 = 20$ teeth) is not fixed to the pink input crank.

The green output gear irregularly continuously rotates faster than the pink input crank in the same direction.

1 revolution of the pink input crank corresponds 2 revolutions of the green output gear.

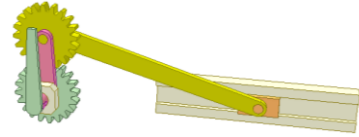

External gear slider mechanism 2

<http://youtu.be/QSRgQfbgLiI>

The yellow gear ($Z_2 = 20$ teeth) is fixed to the connecting rod.

The green gear ($Z_1 = 40$ teeth) is not fixed to the pink input crank.

The green output gear irregularly continuously rotates faster than the pink input crank in the same direction.

1 revolution of the pink input crank corresponds 1.5 revolutions of the green output gear.

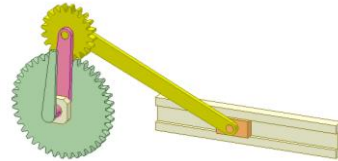

External gear slider mechanism 3

<http://youtu.be/rzXoR-OXLtA>

The yellow gear ($Z_2 = 60$ teeth) is fixed to the connecting rod.

The green gear ($Z_1 = 20$ teeth) is not fixed to the pink input crank.

The green output gear irregularly continuously rotates faster than the pink input crank in the same direction.

1 revolution of the pink input crank corresponds 4 revolutions of the green output gear.

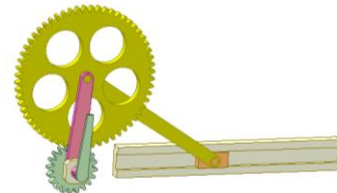

Internal gear slider mechanism 1

<http://youtu.be/tup8vGK4smA>

The yellow gear ($Z_2 = 80$ teeth) is fixed to the connecting rod.

The green gear ($Z_1 = 20$ teeth) is not fixed to the pink input crank.

The green output gear irregularly continuously rotates faster than the pink input crank in the opposite direction.

1 revolution of the pink input crank corresponds 3 revolutions of the green output gear.

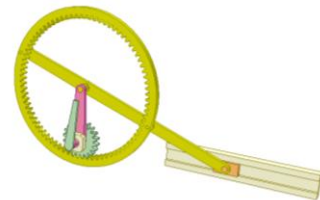

Internal gear slider mechanism 2

<http://youtu.be/CbFPxpRHyRI>

The yellow gear ($Z_2 = 20$ teeth) is fixed to the connecting rod.

The green gear ($Z_1 = 80$ teeth) is not fixed to the pink input crank. The green output gear irregularly continuously rotates slower than the pink input crank in the opposite direction.

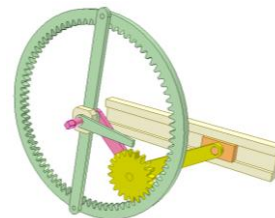

Internal gear slider mechanism 3

<http://youtu.be/diW797QmiyA>

The yellow gear (radius $r_2 = 30$) is fixed to the connecting rod.

The green gear (radius $r_1 = 60$) is not fixed to the pink input crank.

Crank length: $R = 60$

Connecting rod length: $L = 90$

($r_1 = L - R$)

The green output gear irregularly rotates (with dwell) 2 revolutions when the pink input crank rotates 1 revolution in the opposite direction.

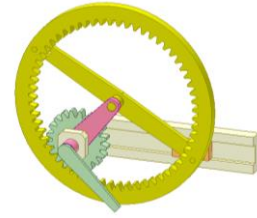

Internal gear slider mechanism 4

<http://youtu.be/W8Hv6cRyUTU>

The yellow gear (radius $r_2 = 30$) is fixed to the connecting rod.

The green gear (radius $r_1 = 60$) is not fixed to the pink input crank.

Crank length: $R = 60$

Connecting rod length: $L = 70$

(r_1 longer than $L - R$)

The green output gear irregularly rotates (with going back) 2 revolutions when the pink input crank rotates 1 revolution in the opposite direction.

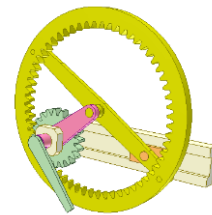

Three-gear-slider-crank mechanism 1

http://www.youtube.com/watch?v=jq_Jl7BmXec

Modified-Watt's reverser

Teeth numbers of two large gears $Z_1 = Z_2 = 40$

Teeth number of the small gear $Z_0 = 20$

Gear module $m = 2$

Length of the pink crank $a = 180$

Length of the green connecting rod $b = 220$

The output blue gear reverses after each 180-degree rotation of the input pink crank.

The output gear oscillates through the same angle as the green connecting rod.

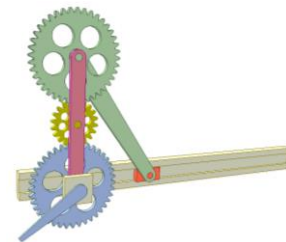

Three-gear-slider-crank mechanism 2

<http://youtu.be/DD5w0B8hpCq>

Teeth numbers of two small gears $Z_1 = Z_2 = 20$

Teeth number of the large gear $Z_0 = 40$

Gear module $m = 2$ mm

Length of the pink crank $a = 150$ mm

Length of the green connecting rod $b = 220$ mm

The output blue gear irregularly continuously rotates slower than the pink crank in the same direction. 2 revolutions of the pink crank corresponds 1 revolution of the output blue gear.

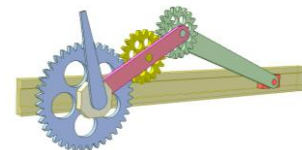

Three-gear-slider-crank mechanism 3

<http://youtu.be/aZl5tY-00J4>

Teeth numbers of two small gears $Z_1 = Z_2 = 20$

Teeth number of the large gear $Z_0 = 40$

Gear module $m = 2$ mm

Length of the pink crank $a = 150$ mm

Length of the green connecting rod $b = 220$ mm

The green gear irregularly rotates (with going back) 1 revolution when the pink crank rotates 1 revolution in the opposite direction.

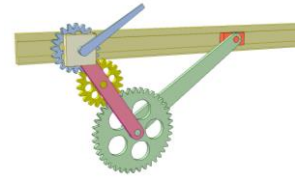

Guiding pulley

<https://youtu.be/QxfErrBm8mc>

Blue disk has sliding joint (3 cylindrical pins) with glass pulley and both can rotate around pink fixed worm. Glass pulley can move axially but the disk not.

Yellow worm wheel and orange cam (an eccentric) are fixed together and rotate on a pin of the blue disk thanks to the fixed worm. Violet roller mounted on the pulley is forced toward the cam by three green springs.

A moving strip (not shown) makes the glass pulley and the blue disk rotate by friction. At the same time the pulley slowly reciprocates axially under action of the cam and roller, thus gives the strip lateral motion.

Red screw is for reducing axial stroke of the pulley (limiting its motion to the right).

An unusual thing in this mechanism: a worm wheel rotates around a worm. See also:

<http://www.youtube.com/watch?v=4gS5QgwIkok>

<http://youtu.be/RcsllgLLm70>

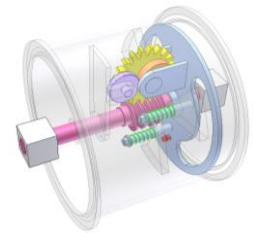

Bevel gear and slider mechanism

<http://youtu.be/jrYQ6wZDRbw>

Input is pink gear of constant velocity.

Yellow bars have spherical joints with green gears and cylindrical joints with violet slider.

The slider linearly reciprocates.

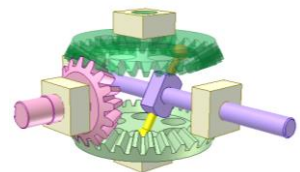

5.4. Cams

Disk cam mechanism DF9

<http://youtu.be/F3scqTa1CDw>

The cam profile is an Archimedean spiral so the follower's speed is constant. Gravity maintains permanent contact between follower and cam.

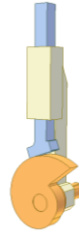

Gear cam

<http://youtu.be/4p-6tIA-kuc>

The orange cam is a combination of disk cam and internal gear.

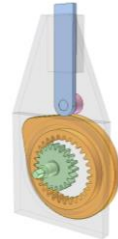

Disk cam mechanism DF1

<http://youtu.be/AWq7r9YwU48>

The roller is bigger than the cam.

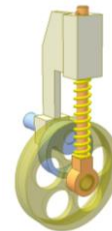

Disk cam mechanism DF2

http://youtu.be/gAyj_MAgmrQ

The follower has two rollers contacting both sides of the cam rim of thickness A . If A is constant, distance between the rollers is slightly bigger than A .

If backlashless is required, A must be inconstant.

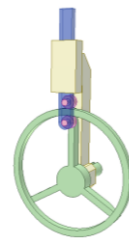

Disk cam mechanism DF3a

<http://youtu.be/QoMAMxIJRCo>

The follower has two rollers that move in the cam's slot. Rollers axes are slightly eccentric so the orange roller contacts with the outer wall of the slot; the pink roller contacts with the inner wall of the slot. This prevents the sliding of roller that happens in slot cam of one roller.

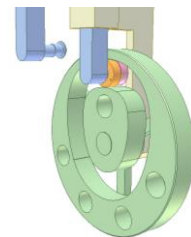

Disk cam mechanism DF3b

<http://youtu.be/Wodc-C4a1m4>

The follower has two rollers that move in the cam's slot. The slot is designed in the way that the orange roller contacts only with the outer wall of the slot; the pink roller contacts only with the inner wall of the slot (the slot outer wall is stepped). This prevents the sliding of roller that happens in slot cam of one roller.

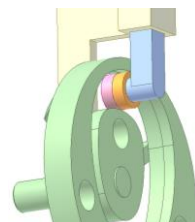

Disk cam mechanism DF3c

<http://youtu.be/-uQCJx5bwBg>

The follower has two rollers (of different diameters) that move in the cam's slot. The slot is designed in the way that the orange roller contacts only with the outer wall of the slot; the pink roller contacts only with the inner wall of the slot. This prevents the sliding roller that happens in slot cam of one roller.

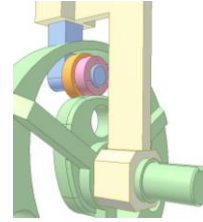

Cam-slider mechanism

<http://youtu.be/NLNBzZuOZiA>

Input: pink crank.

Output: cam-slider that linearly reciprocates.

Its velocity is almost constant with the shown 8-shaped cam profile.

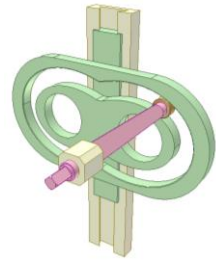

Multi-profile cam

<http://youtu.be/TLZ2vqH31zo>

Left mechanism:

Blue cam contains various profiles. Its follower has some identical pins. This design helps reduce cam dimension and avoid cam-follower contact near to the cam center.

Geometric closure by pins causes a considerable backlash.

Right mechanism is shown for comparison purpose.

Red cam has continuous profile of Archimedean curves. Its dimension is to be large to reduce pressure angle at cam-follower contact points near to the cam center.

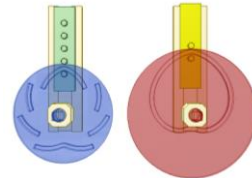

Disk cam mechanism DF4a

<http://youtu.be/QFqPjGilbzY>

A working period of the mechanism corresponds two revolutions of the green slot cam. The pink rhomb-shaped part plays role of roller.

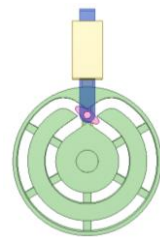

Disk cam mechanism DF4b

http://youtu.be/Sae9B_61i0I

A working period of the mechanism corresponds three revolutions of the green slot cam. The pink rhomb-shaped part plays role of roller.

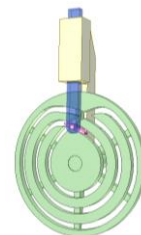

Disk cam mechanism DF4c

<http://youtu.be/iVQVF-SQea8>

A working period of the mechanism corresponds two revolutions of the green slot cam. The pink guides help the roller go through the slot cross. Springs forcing the guides against the yellow pins are not shown. This roller concept is used instead of a rhomb-shaped slider when the slot's curvature is small.

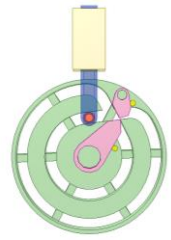

Disk cam mechanism DF12

<http://youtu.be/ssvJhSpCISl>

Working cycle of the mechanism is 2 revolutions of the green cam. The pink guide helps roller come into the outer groove one time in every two rev. A spring toggle device and two yellow pins maintain right positions of the guide.

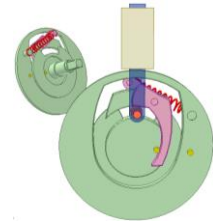

Disk cam mechanism D8a

<http://youtu.be/AvxtHLCeykE>

Cam mechanism of geometrical closure. To maintain backlashless, the distance between any two points of the cam theoretic profile laying on the line through the cam's center (parallel to the sliding direction of the follower) must be constant.

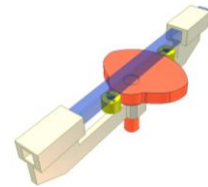

Disk cam mechanism DF8b

<http://youtu.be/twiPc5QzxmM>

Cam mechanism of geometrical closure.

To maintain backlashless, the distance between any two points of the cam theoretic profile laying on the line through the cam's center (parallel to the sliding direction of the follower) must be constant. The cam profile is a n-fold rotational symmetric closed curve, n is an odd number (here $n = 3$).

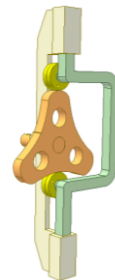

Disk cam mechanism DF10a

<http://youtu.be/mCbe9RD61aA>

With eccentric round cam the follower gets harmonic motion.

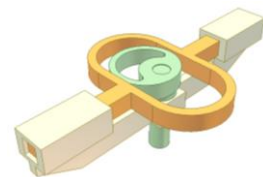

Disk cam mechanism DF10b

<http://youtu.be/DhKg3nntPIA>

Reuleaux triangle cam. The rotation center and the curved triangle's one are coincident. The follower goes forward and backward three times in one cam revolution.

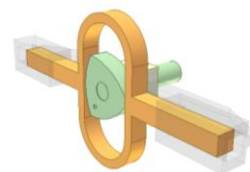

Disk cam mechanism DF10c

<http://youtu.be/hLEnUOu2-kU>

Reuleaux triangle cam. The follower goes forward and backward one time in one cam revolution with short dwell at stroke's ends.

Stroke length = DB



Disk cam mechanism DF10e

<http://youtu.be/8NKh9lxNnTI>

Reuleaux triangle cam. The follower goes forward and backward one time in one cam revolution with long dwell at stroke's ends.

Stroke length = DB + R



Disk cam mechanism DF8d

<http://youtu.be/61oZWpqJ2yl>

Dual cam.

The main cam is pink. The yellow one is added for cam geometrical closure.

Its profile must be designed to maintain permanent contact of both rollers with cams.

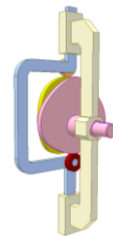

Disk cam mechanism DF8e

<http://youtu.be/kjo85swsOrU>

Dual cam.

The main cam is pink. The yellow one is added for cam geometrical closure.

Its profile must be designed to maintain permanent contact of both follower's planes with cams.

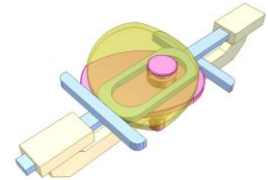

Cam driven press

<http://youtu.be/hbtKTa6rCWg>

Cam in combination with toggle mechanism gives high pressing force.



Fixed cam mechanism 4

<http://youtu.be/0ZTaScDawKs>

The yellow cam is fixed. The blue follower moves in a groove of the input crank. Length of the yellow rod plus radius of the magenta roller equals profile radius of the yellow cam. The violet slider reciprocates with dwell at its leftest position. Adjust position of the magenta nuts for various stroke lengths and dwell times.

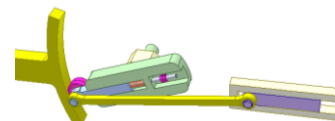

Fixed cam mechanism 5

<http://youtu.be/1HdJEO3iHrM>

The orange cam of contact radius R is fixed. The green follower of contact radius r has planar motion. If $R = 2r$ and the axis of the contact cylindrical surface of the fixed cam intersects sliding axis of the blue slider (case of Cardano circles), the green follower rolls without sliding on the fixed cam.

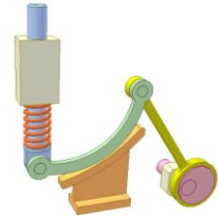

Cam mechanism of follower's planar motion 3

<http://youtu.be/z3rnRqAbRBo>

The orange cam is a triangle of six curves (curved polygon of constant width). The green follower has planar motion and the pink slider reciprocates with dwells at both stroke ends.



Disk cam assembly 3

<http://youtu.be/0xx98A1VFlg>

Cam 1 is a green round disk. The orange cam 2 is fixed on cam 1. Its position can be adjusted to get various motions of the follower, both in stroke length and in phase by moving the two pink T-slot bolts. Gravity maintains permanent contact between rollers and cam.

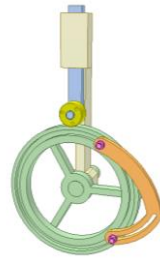

Disk cam mechanism DF5

<http://youtu.be/QBGc2VD-drM>

Adjust rollers distance to alter dwell time of the follower. Gravity maintains permanent contact between rollers and cam.

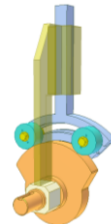

Disk cam mechanism DF6

<http://youtu.be/rvAWqUyXKLE>

The green main cam moves the plunger to up position which is maintained by orange latch. The cyan springs forces the latch against the violet catch. The red pin lets the plunger go down by unlatching the orange latch. Dwell time is obtained by adjusting the red pin's position on the main cam.

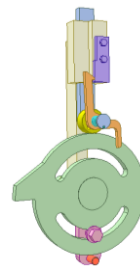

Disk cam mechanism DF7

<http://youtu.be/BkPOyRcEZVA>

Input is the green shaft, on which the orange cam rotates idly. Motion is transmitted to the cam through the pink pin. A quick drop of the follower is obtained by permitting the cam to be pushed out of the way by the follower itself as it reaches the edge of the cam. Gravity maintains permanent contact between follower and cam.

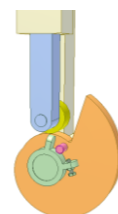

Disk cam mechanism DF11 F4

<http://youtu.be/D2iXGzzfxiU>

Beside the pink roller, the follower also has flat portion that contacts the cam after the roller leaves the cam at the follower's highest position. This helps increase dwell time at the highest position and speed up the follower's return. Gravity maintains permanent contact between follower and cam.



Archimedes groove cam

<http://youtu.be/rJtRcneZ71A>

The green cam rotates continuously. The motion reverse of the blue follower is due to the yellow toggle arm carrying two orange pins and the cam groove depth reduction at groove outer end.

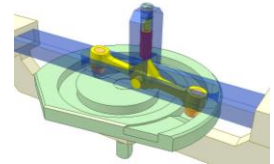

Cam and crank slider mechanism 2

<http://youtu.be/bZR6D3-jCDA>

Input is the orange crank. The blue output slider performs two double strokes during one revolution of the input.

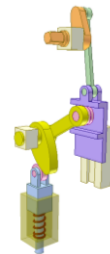

Disk cam mechanism DF8c

<http://youtu.be/Y5mNeE00O58>

Two rollers and special shape of the cam slot help to increase stroke length.

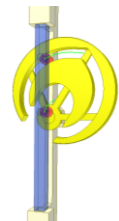

Radial cam

<http://www.youtube.com/watch?v=UJtXt0RGG84>

A measure to increase follower stroke while unchanged pressure angle. Shortcoming: to transmit rotation to a moving shaft.

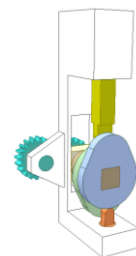

Floating disk cam

<https://youtu.be/6rDxGvSD2Ck>

Input: pink shaft.

Output: green follower.

A measure to increase follower stroke while keeping pressure angle small.

Pink shaft goes down thanks to its weight.

The gravity maintains the cam-follower contact.

Disadvantage: to transmit rotation to a moving shaft.

If violet bearing is kept immobile, the follower stroke will be reduced.

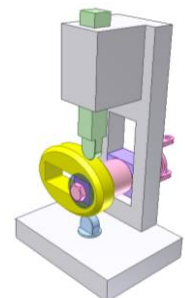

Disk cam of adjustable output stroke length

<https://youtu.be/UjDgezJ2Gh0>

Input: grey cam.

Output: yellow slider.

Red pin fixed on green cam follower moves in cross groove of the output slider.

Turn the blue swivel runway to get various output stroke lengths.

The video shows the adjustment process to get from 0 to max stroke length.

Measure to fix the blue swivel runway after adjustment is not shown.

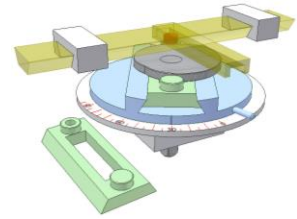

Disk cam of automatic variable stroke

<https://youtu.be/l-qF5stFzqk>

An application of Ferguson's paradox shown at:

<https://youtu.be/Paw4aKYjtb0>

Input: pink gear of tooth number $Z_p = 20$.

The pink gear engages with grey and green gears.

Tooth number of the grey gear $Z_g = 20$.

Tooth number of the green gear $Z_e = 21$.

Grey cam is fixed to the grey gear.

Green cam is fixed to the green gear.

There is a relative rotation between the cams (very slow, $1/21$ rev. in 1 rev. of the input).

Different relative positions of the cams make the blue follower strokes change after every input revolution. The video shows how the follower stroke is increased.

The spring to maintain the contact between orange roller and the cams is not shown.

It is said that the mechanism is used in machine making paper pipes with $Z_g = 104$, $Z_e = 105$.

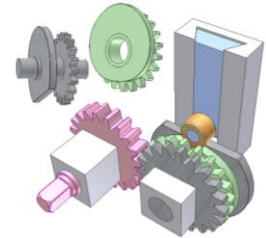

Cam and wedge mechanism

http://youtu.be/ChVw3_NZ3B8

The eccentricity of the green eccentric can be adjusted by turning the orange screw to move the pink wedge shaft. The latter and the yellow gear are fixed together. Input: the grey gear. Output: the red follower.

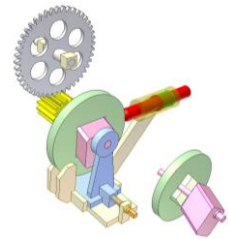

Cam and crank slider mechanism 3

<http://youtu.be/86dNyTDILkA>

Input is the yellow cam. Stroke length of the orange output slider can be adjusted by moving the red slider.

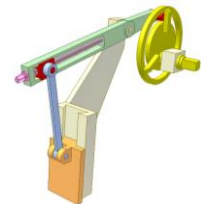

Cam and crank slider mechanism 4

<http://youtu.be/SXp3gx46f7w>

Input is the yellow cam. Stroke length of the orange output slider can be adjusted by moving the grey slider.

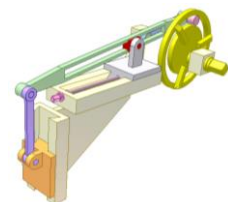

Cam and crank slider mechanism 5

<http://youtu.be/9wReecQgktc>

Input is the yellow cam. The follower consists of two bars connected together by a revolution joint and the orange spring. Once the orange bar collides with the violet screw, oscillating center of the follower is changed. Stroke length of the blue output slider can be varied by adjusting the violet screw.

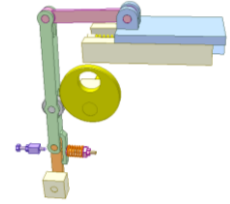

Cam and gear mechanism 3

<http://youtu.be/lzJTbc3wkj8>

Input is the orange gear to which a small cam is fixed. The green gear and large cam are fixed together. Transmission ratio of the gear drive is 4.

The output pink slider, in its right to left course, has added motions during its three dwells.

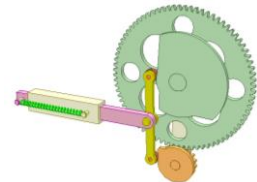

Cam and gear mechanism 5

<http://youtu.be/UI5KDnQ9gTM>

Input is the green shaft with a green gear and an eccentric portion on which the pink conrod idly rotates. The yellow output slider receives motion from the blue arm that has a pin sliding in the groove of the cam fixed on the orange gear. Transmission ratio of the gear drive is 1. The blue arm is also connected to the violet slider that received motion from the pink conrod.

The motion combination gives long stroke of the yellow slider, a slotter's ram.

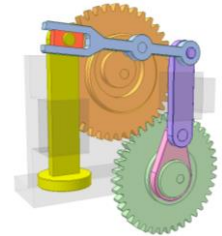

Cam and gear mechanism 6

<http://youtu.be/CbPPV0D2fGM>

Input is the yellow shaft having a gear and a disk. The cyan slider (a cam) reciprocates in a slot on the disk due to the red cam that fixed to the red gear. The red gear receives motion from the yellow gear through the blue and the green gears. The orange slider's roller can contact with the yellow disk and the cyan slider. Motion of the orange output slider depends on the cam's shape, its angle position on the red gear and the transmission ratio (= 4 for this case) of the 4-gear drive.

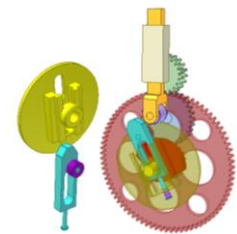

Inclining disk mechanism 1

<http://www.youtube.com/watch?v=zrpZcZCRA1s>

Flat contact. The follower rotates during reciprocation.

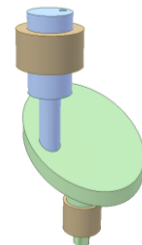

Inclining disk mechanism 2

<http://www.youtube.com/watch?v=YsUQDb3cdhE>

Application for engine. Flat contact with added spherical joints.

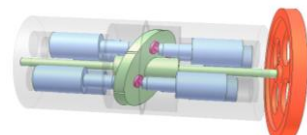

Inclining disk mechanism 3

<http://www.youtube.com/watch?v=PkVVoCKGB5w>

Two balls are inserted between contact faces of the disks and the slider.

Stroke time corresponds two revolutions of the disk.

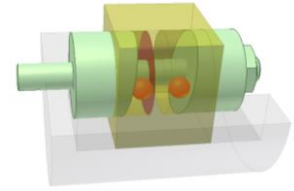

Inclining disk mechanism 4

<http://www.youtube.com/watch?v=dafYYCBo4VU>

A rational design: flat contact, joint geometric closing, possibility of gap regulation.

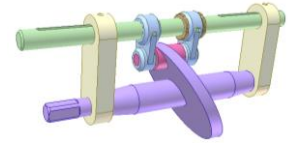

End cam mechanism ET1

<http://youtu.be/qmABJ5lbnhc>

The identical helical surfaces of the cam and the follower increases contact area and load capacity considerably. Gravity maintains permanent contact between follower and cam.

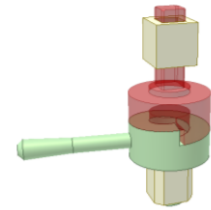

End cam mechanism ET2

<http://youtu.be/5jE6yDqVbek>

This steel-ball cam can convert the high-speed rotary motion of an electric drill into high-frequency vibrations that power the drill core for use as a rotary hammer for cutting masonry and concrete.

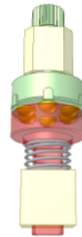

Facial cam

<http://www.youtube.com/watch?v=hBh7dd36Vrc>

A measure to increase follower stroke while unchanged pressure angle.

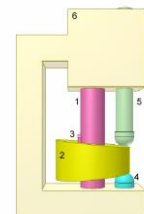

Facial cam 1b

<http://youtu.be/THHIXrYS -4>

A measure to increase follower stroke while unchanged pressure angle. Gravity maintains contact between rollers and cam.

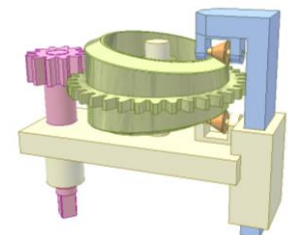

Barrel cam mechanism BT1a

<http://youtu.be/LLlwVdaRViM>

The space cam of helical slots of two opposite hands and different pitches (screw of two opposite hand threads) gives the blue follower reciprocal linear motion. The go speed is slow and the back one is fast.

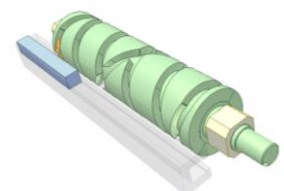

Barrel cam mechanism BT2a

<http://youtu.be/Atvhzgple5l>

Rotational motion is converted into linear reciprocating one.

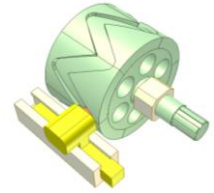

Barrel cam mechanism BT2b

<http://youtu.be/HEJNQgBowHw>

A development of mechanism shown in:

<http://youtu.be/Atvhzgple5l>

Rotational motion is converted into linear reciprocating one.

Input and output shafts are in line.

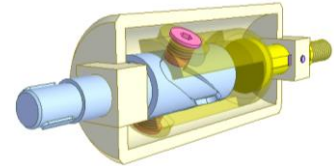

Barrel cam mechanism BT3

<http://youtu.be/RuioMWd1NXU>

A mixing drum has a small oscillating motion while rotating due to a barrel mechanism at the end of its shaft. It finds application in mixing paint, candy or food.



Barrel cam mechanism BT8

<http://youtu.be/rmBnpM7K6To>

The green barrel cam has two grooves. Motion of the yellow slider can be altered by rotating the orange gear to let one of two rack's rollers come into contact with its corresponding cam's groove.

The positioning device for the orange gear is not shown.

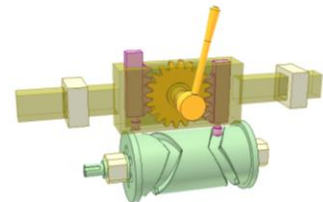

Barrel cam BT9

https://youtu.be/huiBTi_9UtI

Turning green bush makes blue tube (slider) move longitudinally. Pink pin is fixed to the blue tube and through a helical slot of the green bush, it contacts with a longitudinal groove made on inner surface of the base.

Advantage: reducing overall length.

Unique thing for this mechanism: no direct contact between blue slider and the base.

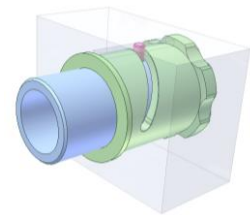

Barrel cam assembly 1

<http://youtu.be/jsqA7GFfM8E>

The yellow cam is fixed to the green cam drum by T-slot bolt that enable to change the cam or adjust its position on the drum.

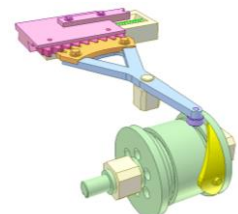

Barrel cam assembly 2

<http://youtu.be/sSXEkDnkbqc>

By T-slot bolts the positions of violet rollers on the green cam drum can be adjusted to get various motions of the pink slider,

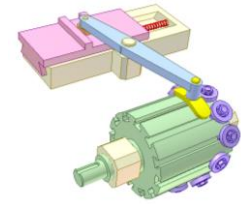

Cone cam 1

http://youtu.be/p2_4CQA2QT0

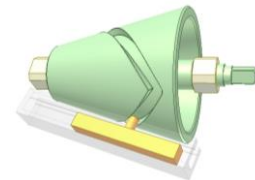

Cone cam for cutting chopsticks head

<https://youtu.be/ASNOz3PTrYE>

It is a device from the automatic machine making bamboo chopsticks. Each pink follower has its pin moving in the groove of brown inner cone cam. Cutters fixed to the followers move obliquely radially to create yellow chopsticks head of pyramid shape.

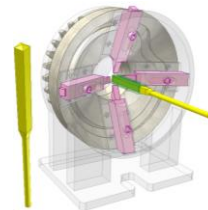

Hyperboloid cam

<http://youtu.be/F9eP9wh0KqQ>

The follower sliding line and the cam rotary axis are skew.

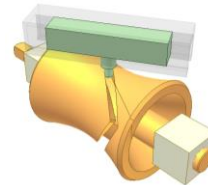

Inclined barrel cam

<https://youtu.be/D6QnTreGfhU>

Input: pink shaft having key sliding joint with inclined barrel cam.

Output: blue follower moving in accordance with sine function. Its stroke length can be adjusted thanks to green screw.

The non-stop adjustment is possible (without stopping cam rotation).

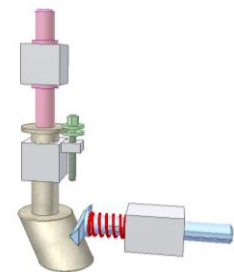

Taper helical cam

https://youtu.be/NzuvxO_Woz4

Input: pink cam that performs reciprocating rotation (more than 1 rev. is possible).

Output: blue follower of planar motion.

The gravity maintains cam-roller contact.

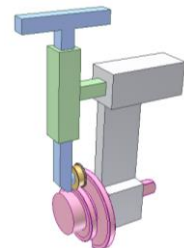

End cam mechanism ET3

http://youtu.be/CCu_U7kZhEQ

The blue slider during its every four double stroke gives the yellow slider only one double stroke by meshing lower end of the orange pin with a hole on the driven yellow slider.

The violet pin makes the orange pin rotate 90 deg. interruptedly.

The end cam on the blue slider makes the orange pin move up/down.

A device for positioning the yellow slider at its rest position is not shown.

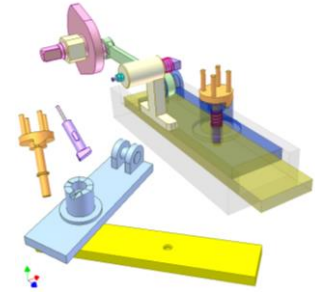

5.5. Chains

Chain drive 2A

<http://youtu.be/iXbi7iod57Y>

Rotation to linear reciprocation. The two sprockets have the same tooth number.

This mechanism is applied in bamboo cleavage machine.

See a machine made in Vietnam:

http://www.youtube.com/watch?v=MUzykcMLtdo&feature=player_embedded



Chain drive 2B

<http://youtu.be/0jGOkJHN574>

The orange sprocket is driving. The two sprockets have the same tooth number. The pink slider reciprocates with constant velocity.

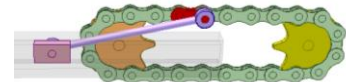

Chain drive 2C

<http://youtu.be/6Je0ol6CKcg>

Rotation to linear reciprocation with dwell at the ends of the stroke. The two sprockets have the same tooth number. The pink slider reciprocates with constant velocity.

This mechanism is applied in wire drawing machines for leading wire (in red) to its coil.

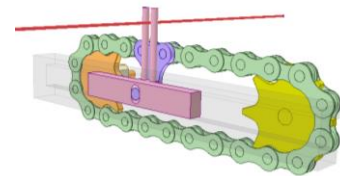

Chain drive 2D

<http://youtu.be/vzGjNXuiqp0>

Rotation to linear reciprocation with dwell at the ends of the stroke of the yellow slider. The two sprockets have the same tooth number. The pink pawls tend to rotate clockwise by springs (not seen). The red chain link pushes the yellow slider through the pawls and leave them when the pawls hit the violet adjustable stoppers.

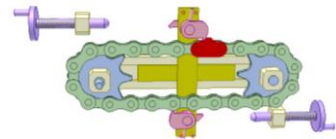

Chain drive 2E

<http://youtu.be/MsCYaTDbZsI>

Converting continuous rotation into reciprocating translation with dwells at both ends of the course.

Two sprockets are identical.

The course length is equal to sprocket pitch diameter.

The dwell time depends on the axle distance of two sprockets.

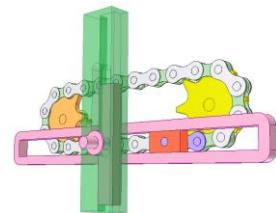

Chain drive 2F

<http://youtu.be/VGUs5yiObmQ>

Converting continuous rotation into reciprocating translation with dwells at both ends of the course.

Two sprockets are identical.

The course length depends on sprocket pitch diameter and lengths of the blue and pink bars.

The dwell time depends on the axle distance of two sprockets.

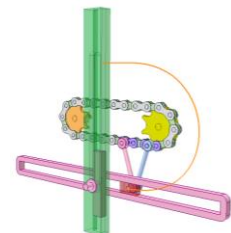

Chain drive 8A

<http://youtu.be/Or0k0VpDtBw>

Converting continuous rotation into reciprocating translation with dwells at one end of the course.

Three sprockets are identical. The pink one is driving. The violet chain link has an axle for a revolution joint with the red slider.

The course length depends on vertical axle distance between the pink sprocket and the orange ones.

The dwell time depends on axle distance of two orange sprockets.

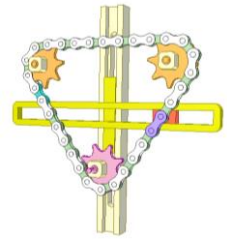

Chain drive 8C

<http://youtu.be/7-0wXqRga4M>

Converting continuous rotation into reciprocating translation with different times of go and back strokes.

Three sprockets are identical. The pink one is driving. The violet chain link has an axle for a revolution joint with the red slider.

The sprockets are arranged at vertices of an equilateral triangle so the ratio of go and back times is 2.

The course length depends on sprocket axle distance.

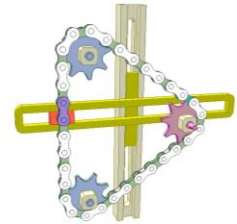

Chain drive 9

<http://youtu.be/TIkOzXQpVL4>

Converting continuous rotation into reciprocating translation with dwells at both ends of the course.

Three sprockets are identical. The orange one is driving. The violet chain link has an axle for a revolution joint with the red slider.

The course length depends on vertical axle distance between upper and lower sprockets.

The dwell time depends on horizontal axle distance between right and left sprockets.

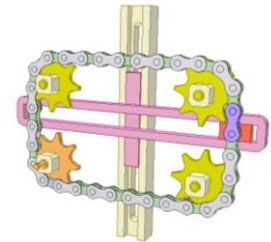

Chain drive 10

http://youtu.be/V0_wqv0y7rq

Converting continuous rotation into reciprocating translation with dwells in the middle of the course.

Four sprockets are identical. The orange one is driving. The violet chain link has an axle for a revolution joint with the red slider.

The course length depends on vertical axle distance between the orange sprocket and the top one.

The dwell time depends on horizontal axle distance of two middle sprockets.

This video shows the possibility to create reciprocating translation with dwell at any point of the course by using chain drive with four sprockets and arranging them at appropriate positions.

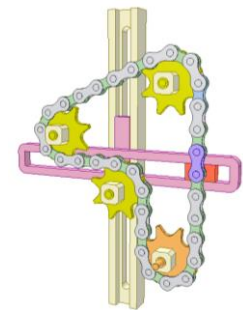

Cable drive 22

<http://youtu.be/F5vEXHPw6o>

Converting continuous rotation to reciprocating translation.

An arm on the pink shaft turns the blue wheel when contacting with its pins. The arm moves axially to release the wheel when contacting with the orange wedges.

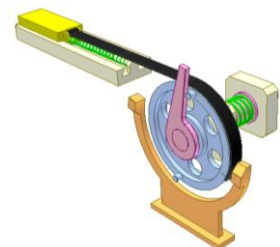

5.6. Friction drives

Spatial friction drive for translating motion 1a

<http://youtu.be/i2J5au2czKo>

Input: orange shaft rotating regularly.

Output: yellow slider moving linearly.

Turn the green swivel to change motion direction of the slider.

The slider velocity V depends on the skew angle λ between axes of the input shaft and the roller.

$$V = \omega \cdot R \cdot \tan(\lambda)$$

ω : angular velocity of the input shaft

R : contact radius of the input shaft

Pink roller is forced toward the input shaft by red spring.

Small violet slider is for positioning the green swivel.

The mechanism is for light duty works.

Kinematic relation between the input and output is not kept strictly due to contact slipping.

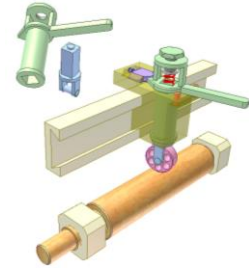

Spatial friction drive for translating motion 1b

<http://youtu.be/XZy856ocYgk>

Input: orange shaft rotating regularly.

Output: yellow slider linearly reciprocating.

The slider velocity depends on the skew angle between axes of the input shaft and the roller.

Pink roller is forced toward the input shaft by a spring (not shown).

The automatic changing motion direction is performed by a spring toggle mechanism that consists of blue and green levers, red spring and two cyan adjustable stoppers. Refer to:

<http://youtu.be/KaRBadgcUIU>

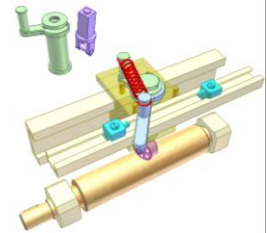

6. Converting rotary oscillation into linear motion and vice versa

6.1. Gears

Rack pinion mechanism 1

<http://www.youtube.com/watch?v=9hl85qZ5zKA>

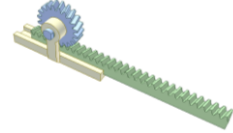

Sheet metal gears 2

http://youtu.be/b01b8Df4_88

For light loads.

Low cost.

Adaptability to mass production.



Rack with ring teeth

http://youtu.be/1qpLembF_mU

The mechanism acts as an ordinary rack pinion drive, furthermore the rack can rotate around its axis during transmission.



Pin rack drive 1A

<http://youtu.be/ZyhJPFERF-k>

The pinion tooth profile is the envelope of a family of the pin circles, centers of which are on an involute traced by pin circle center when the pin rack rolls without slipping on the pinion.

The pinion can engage both sides of the pin rack. It is impossible for the tooth rack.

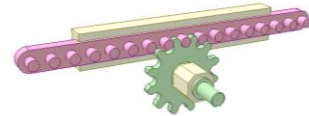

Pin rack drive 1B

<http://youtu.be/kMXqu5HfcBg>

The rack tooth profile is the envelope of a family of the pin circles, centers of which are on a cycloid traced by pin circle center when the pin wheel rolls without slipping on the rack.

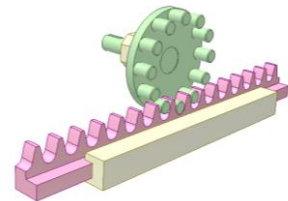

Application of rack pinion mechanism 4

<http://www.youtube.com/watch?v=uEGpsi4upw8>

A measure to reduce force applied to the runway.

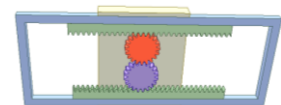

Gear-rack drive 2

<https://youtu.be/mlfe6cwvix0>

Input: pink piston.

Output: blue runway.

This video aims to show the motions of a gear-rack drive when the gear (in grey) is stationary.

This mechanism converts linear motion of yellow slider, to which yellow rack is fixed, into rotation of the blue runway.

Green line is traced by a point on rolling line of the rack. It is an involute.

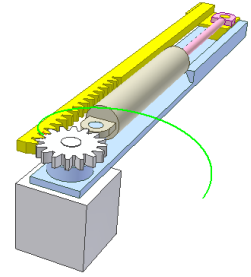

Rack pinion mechanism 4b

<http://youtu.be/MSq2xD6OcMA>

The pink input rack reciprocates. The green output shaft oscillates with dwell at one end of its stroke.

The rack flat portion prevents spontaneous motion of the shaft.

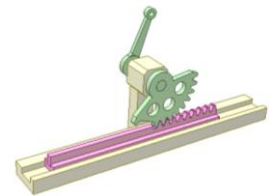

Rack pinion mechanism 4c

<http://youtu.be/BjmKHHR18w8>

The pink input rack reciprocates. The green output shaft oscillates with dwell at both ends of its stroke.

The rack flat portions prevent spontaneous motion of the shaft.

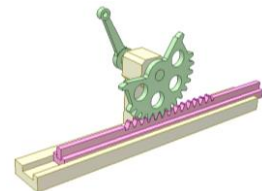

Rack pinion mechanism 4e

<http://youtu.be/f7J54RvmApc>

The green input shaft rotary reciprocates. During the go or back motion the velocity of the pink output slider changes in steps.

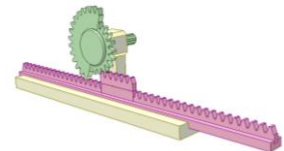

Rack pinion mechanism 4a

<http://youtu.be/v46JRgJ2zbU>

The pink input rack reciprocates. The green output shaft oscillates with dwell in the middle of its stroke.

The rack flat portion prevents spontaneous motion of the shaft.

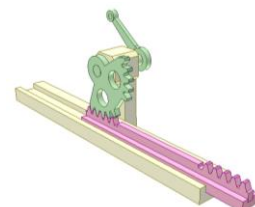

Rack pinion mechanism 7

<https://youtu.be/8P9ysNPBrB0>

Input: green frame reciprocating.

Output: orange gear.

In one stroke (back-and-forth) of the frame the gear reverses 6 times.

This mechanism is numbered as 269 in the book "507 mechanical movements", 1868.

<http://507movements.com/about.html>

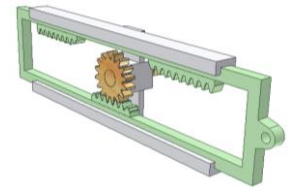

Reverse mechanism for rack

http://youtu.be/Bxtthb_6bO8

The large gear rotates continuously.

Use the blue lever to control motion of the rack: stop, forward, back. Positioning device for the lever is not shown.

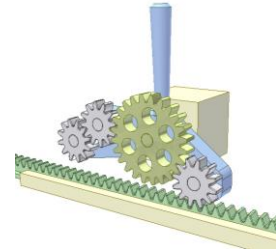

Application of rack pinion mechanism 5

http://www.youtube.com/watch?v=3_3_XFwMplo

Controlling angle of the ship propeller blades

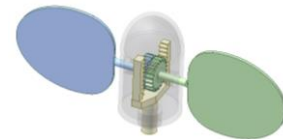

Rack pinion mechanism 6a

<http://youtu.be/3fAMK2phOWE>

Transmission of limited rotation between distant shafts.

Input and output rotary directions are opposite.

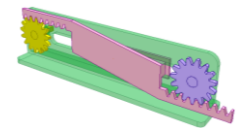

Rack pinion mechanism 6b

<http://youtu.be/M0M-NKzOsZM>

Transmission of limited rotation between distant shafts.

Pitch lines of two rack portions are coincident.

Input and output rotary directions are opposite.

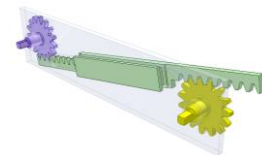

Rack pinion mechanism 6c

<http://youtu.be/5lhNjpdCX8M>

Yellow double rack receives motion from motor via grey worm and orange rack. In fact the orange rack is part of a nut.

The yellow double rack makes two face gears rotate in opposite directions.

Gears and racks are made of sheet metal.

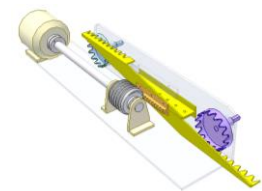

Rack pinion mechanism 6d

<http://youtu.be/uf8BFrcmPgE>

Yellow double rack receives motion from motor via pink worm. The left rack engages with the pink worm and the blue gear. The yellow double rack makes two face gears rotate in opposite directions.

Gears and racks are made of sheet metal.

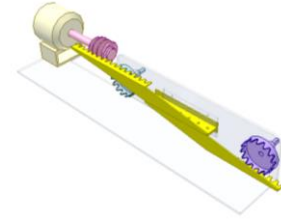

Gear-rack drive

<https://youtu.be/ugSY79imAj8>

Green bracket and blue cylinder are pivoted on the base.

Gray roller bears radial member of gear force.

This design avoids making long runway, ensures easy assembly and reduces friction.

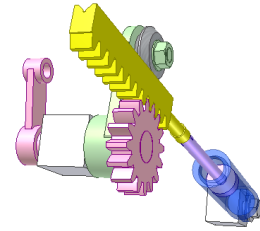

Teeth-uncompleted gear-rack drive for delay motion

https://youtu.be/sH_dAvX6byk

Input: pink shaft having rotary reciprocating motion.

Three identical teeth-uncompleted gears (in green and orange) are keyed on the shaft at different angular positions (the blue gears have the same angular position).

Output three rack-sliders (in blue and yellow). They have linear reciprocating motion with dwells. Their displacements (stroke lengths) are the same but the two blue rack-sliders move forward sooner than the yellow one. The latter moves backward sooner than the two blue rack-sliders.

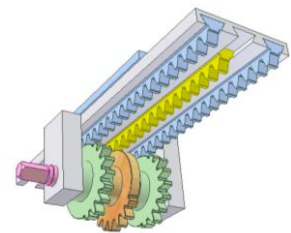

Rack-pinwheel drive 1

<http://youtu.be/wGdxybcaRbo>

Input: pink disk of a pin and a lock arc that rotates reciprocally.

Output: rack that has linear reciprocating motion of sinusoid law.

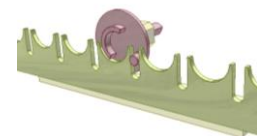

Pin rack drive 5

<http://youtu.be/BM7hnxtP6Y0>

Input: rack that has linear reciprocating motion.

Output: blue gear oscillating 180 deg. with dwells at both ends.

Its motion is of constant speed. Its gear profiles are involutes.

Flat portions on the gear and the rack are for keeping the gear immobile during dwells.

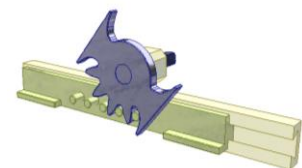

Rack–pinwheel drive 2

<http://youtu.be/nKF5GybAtjU>

Input: pink disk of pins and a lock arc that rotates reciprocally.
Output: rack that has linear reciprocating motion. Its motion is of constant speed. Its gear profiles are cycloids.

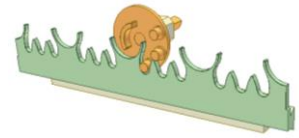

Ratchet mechanism 28

<http://youtu.be/drAELRHgHqI>

Input: blue crank oscillating.
Output: green ratchet rack.
Both go and back motions of the crank make the rack go up.
The pawls pull the rack.
Spring maintains contact between pawls and ratchet rack.



Ratchet mechanism 29

<http://youtu.be/SM7QVSAWztk>

Input: blue crank oscillating.
Output: green ratchet rack.
Both go and back motions of the crank make the rack go up.
The pawls push the rack.
The gravity maintains contact between pawls and ratchet rack.

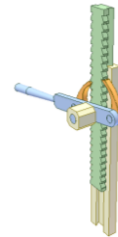

Ratchet mechanism 30

<http://youtu.be/eL2QIyGE2Sq>

Distance between two hooks can be adjusted easily thanks to a round rack and two pawls.

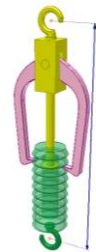

Ratchet mechanism 34

<http://youtu.be/UifSW78QEeU>

Orange roller allows green round rack to move up and prevents it from falling.



Round rack jack 1

<http://youtu.be/dKJP2kc4pMA>

Red pawl pushes yellow rod up when pushing blue lever down.
Orange pawl prevents the rod from falling during the red pawl return.

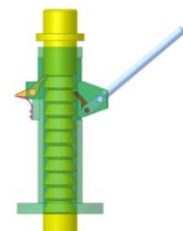

Space gear and rack 1a

<http://youtu.be/54kRNC7K7KI>

This drive consists of a pinion of helical teeth and a rack of helical teeth.

Normal module $m_n = 2$ mm

Pinion:

- Helix angle $B_1 = 30$ deg., left hand
- Face module $m_{s1} = 2.31$ mm
- Tooth number $Z_1 = 15$
- Pitch circle dia. $D_1 = 34.64$ mm

Rack:

- Helical teeth, $B_2 = 13.69$ deg.

Angle between pinion axle and rack moving direction is $L = B_1 + B_2 = 43.69$ deg.

1 pinion revolution makes rack move $\text{Pi} \cdot D_1 \cdot \cos B_1 / \cos B_2 = 97.00$ mm

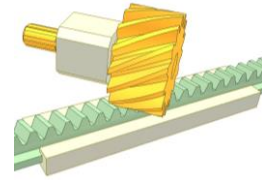

Space gear and rack 1b

<http://youtu.be/ri7evOSAbQ>

This drive consists of a pinion of straight teeth and a rack of helical teeth.

Normal module $m_n = 2$ mm

Pinion:

- Helix angle $B_1 = 0$ deg.
- Tooth number $Z_1 = 15$
- Pitch circle dia. $D_1 = 30$ mm

Rack:

- Helical teeth, $B_2 = 30$ deg.

Angle between pinion axle and rack moving direction is $L = B_1 + B_2 = 30$ deg.

1 pinion revolution makes rack move $\text{Pi} \cdot D_1 \cdot \cos B_1 / \cos B_2 = 108.83$ mm

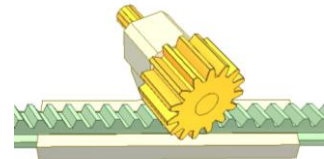

Screw gear and rack 1c

http://youtu.be/Mulq_PUAbeY

This drive consists of a pinion of helical teeth and a rack of straight teeth.

The rack is stationary. The green curve is locus of a point on pinion pitch circle (a space cycloid?).

Pinion: Helix angle $B_1 = 30$ deg., left hand

Rack: Helix angle $B_2 = 0$ deg.

Angle between pinion axle and rack moving direction is $L = 30$ deg.

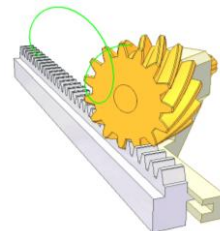

Space gear and rack 1e

http://youtu.be/5IJS_bfkcXI

Angle between pinion axle and rack moving direction is 0 deg.

Normal module $m_n = 2$ mm

Pinion:

- Helix angle $B_1 = 45$ deg.
- Tooth number $Z_1 = 30$
- Pitch circle dia. $D_1 = 84.85$ mm

Rack:

- Helical teeth, $B_2 = 45$ deg.

1 pinion revolution makes rack move $\text{Pi} \cdot D_1 \cdot \cos B_1 / \cos B_2 = 266.56$ mm

This drive resembles a screw-nut one when consider: the gear as a screw, the rack as a bar cut out longitudinally (axially) from a nut.

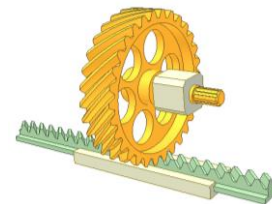

Space gear and rack 1f

<http://youtu.be/h5avf2JatzE>

Lower drive: Space gear and two rack drive, angle between gear axle and rack moving direction is 0 deg. Its two racks move in the same direction.

Upper drive: Planar gear and two rack drive. Its two racks move in opposite directions.

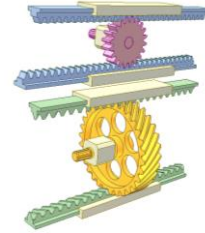

Worm-rack drive 1

<http://youtu.be/nHkfWu0sYc0>

Normal module $m_n = 2$ mm

Input worm:

- Number of starts $Z = 2$
- Lead Angle $LA = 10.81$ deg.
- Direction of thread: right hand
- Pitch circle dia. $D = 20$ mm

Rack:

-Helical, $B_2 = 13.69$ deg.

Angle between worm axle and rack moving direction is $L = LA + B_2 = 24.50$ deg.

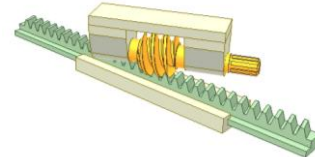

Worm-rack drive 2

<http://youtu.be/FTKTd3EfORo>

Normal module $m_n = 2$ mm

Input worm:

- Number of starts $Z = 2$
- Lead Angle $LA = 10.81$ deg.
- Direction of thread: right hand
- Pitch circle dia. $D = 20$ mm

Rack:

-Helical teeth, $B_2 = -10.81$ deg.

Angle between worm axle and rack moving direction is $L = LA + B_2 = 0$ deg.

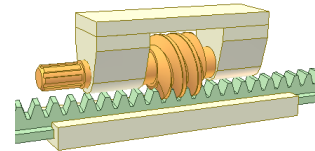

Worm-rack drive 3

<http://youtu.be/cZEc5gwrTM>

The rack is stationary. The blue curve is locus of a point on worm pitch circle (a space cycloid?).

Input worm: Helix angle $B_1 = 30$ deg., left hand

Rack: Helix angle $B_2 = 0$ deg.

Angle between pinion axle and rack moving direction is $L = 30$ deg.

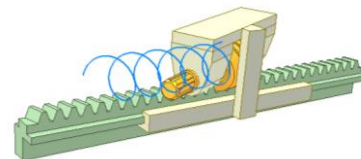

Motion delay mechanism 1

<http://youtu.be/ju3c0naRhhM>

Input: yellow rack reciprocating.

Output: pink rack that moves only after the blue gear makes around two revolutions.

The violet crank rotates idly on the blue gear shaft. Add more violet cranks to increase delay time.

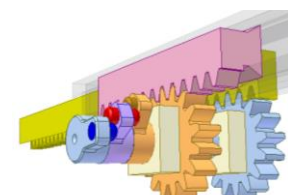

180 deg. interrupted rotation 1

<https://youtu.be/jV-8F3UMxDo>

Input: green chain linearly reciprocating.

Output: grey shaft interruptedly 180 deg. rotating.

This drive with available bicycle freewheel and chain is not costly.

Stroke length of the input $L = 3.142 * R$

R is radius of the blue wheel rolling circle.

The output may be differs from 180 deg. a little due to ratchet mechanism.

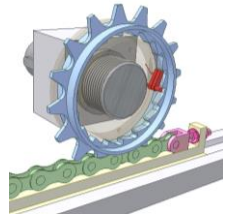

Gear-rack drive for auto reversing linear motion

https://youtu.be/Fele3u6_TJs

Input: pink gear rotating one way.

Output: brown table to which a rack is fixed linearly reciprocating.

Positions of orange stoppers that are fixed to the table decide length stroke of the table.

Snap mechanism (green and violet T-shaped levers, red spring, blue stoppers) ensures that yellow semi clutches do not stop at their neutral positions.

Green V-shaped handle is for pausing the table without stopping the input (see last scene of the video).

This mechanism can be used for planing machines like in following video:

<https://www.youtube.com/watch?v=qGAuX0e9pTc>

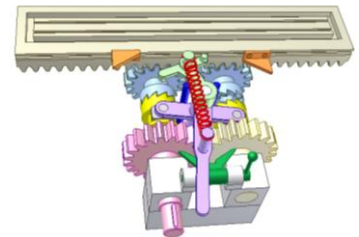

Auto-reverser of spur gears

https://youtu.be/nPXQ_vTtrs

Input: pink shaft to which two gears (P1, P2) are fixed. P2 is teeth-uncompleted gear.

Two blue gears (B1, B2) are fixed to blue intermediate shaft. B2 is teeth-uncompleted gear.

P1 is in mesh with B1.

Output: orange shaft to which two gears (O1, O2) are fixed. O2 is in mesh with green rack.

O1 is in mesh with teeth-uncompleted gears P2 and B2.

Tooth number of P1, B1, O1 and O2: 20.

Tooth numbers of P2, B2:

- teeth-completed: 20

- teeth-uncompleted: 8

Change tooth number of O2 to get various stroke lengths of the green table.

Attention: relative position between P2 and B2 is very important for their proper meshing with O1 so measure to adjust relative position between P2 and P1 (or B2 and B1) is needed (not shown). Placing stopper (not shown) at the end positions of the green table is a measure to help the proper meshing.

This reverser should be used for low speed only because of gear sudden meshing.

Green table reciprocates at constant speed.

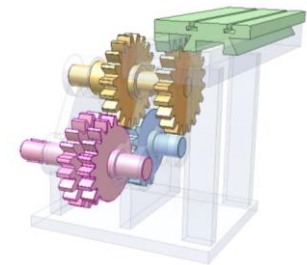

6.2. Bars, cams

Flapping motion 1

https://youtu.be/p7wy_GUa_M4

Orange slider is stationary.

Grey, blue and pink bars have revolution joints with red pin.

Yellow conrods have the same length.

Green slider is fixed to blue bar. Its position can be adjusted.

Violet slider is fixed to grey bar. Its position can be adjusted.

Input: pink bar.

If distances from green and violet sliders to the red pin are equal, angles of blue and grey bars with pink bar are always equal.

The video was made based on suggestion of an YouTube user, wjf213.

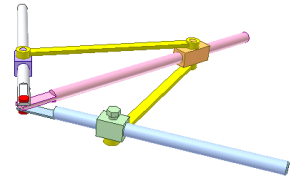

Regular oscilation to regular translation with bar mechanism

<http://youtu.be/JmMer5vCIP4>

The blue pin slides on flat portions of the red lever and of the yellow slider.

Input: the red oscillate lever.

Output: the yellow slider.

Dimension condition: $d = 0.34b$

d : center distance between two revolution joints of the red and green levers.

b : center distance between the blue pin and revolution joint of the green lever.

The slider velocity is constant if the red lever osciltates with a constant velocity in the range ± 30 degrees (angle α) around the line connecting two revolution joints of the red and green levers.

Otherwise stated, the displacement relation between the red lever and the yellow slider is linear. This feature can be used for length measuring tools where the indicator graduation must be even.

In case without the green bar (the red bar has a pin that contact with the flat portion of the yellow slider) the slider velocity alters (cosine function of angle α).

Advantage over rack-pinion drive: high precision of transmission at low manufacture cost.

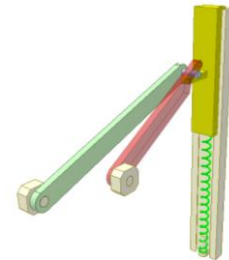

Double parallelogram mechanism 3

<http://www.youtube.com/watch?v=RJBoh5k4KDs>

The mechanism is used for a disappearing platform in a theater stage. The platform moves approximately vertically and has a contra-weight on the blue input link.

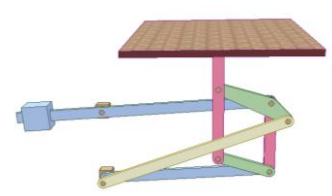

Sarrus linkage 1

<http://youtu.be/pQBjcgJe6t0>

A space linkage of only revolution joints and gives absolutely straight motion. It was invented in 1853, sooner than the planar Peaucellier linkage (1864).

It is the combination of two planar slider-crank mechanisms that lay in two perpendicular to each other planes.

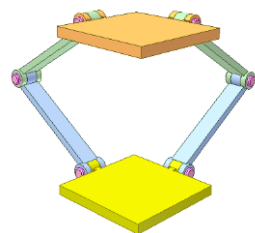

Sarrus linkage 2

<http://youtu.be/CPYbD1GUS1A>

An embodiment of "Sarrus linkage 1".

Two planes of two planar slider-crank mechanisms are not necessary to be perpendicular to each other. It is enough that they are not parallel.

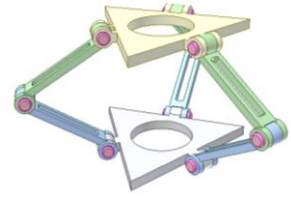

Saurrus linkage 3

<https://youtu.be/ijZml20-w9M>

Linear motion without prismatic joint.

An embodiment of "Sarrus linkage 1".

Input: blue link.

Length of blue, violet, yellow and green links are equal.

Pink link has revolute joints with violet and green links.

Pink link translates along an absolutely straight line (vertical).

Bevel gears are of the same tooth number.

They help to overcome dead position for green and yellow links when they are in line.

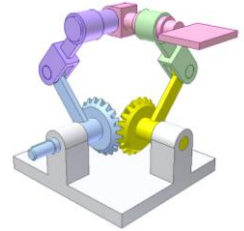

Barrel cam mechanism BT6

<http://youtu.be/pln-xTLa1sQ>

This mechanism converts linear reciprocating motion into oscillating motion or vice versa.

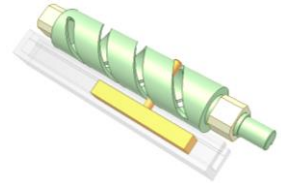

Barrel cam mechanism BT4

<http://youtu.be/nMEpbyMCMdw>

This mechanism converts linear reciprocating motion into intermittent rotation. Key factor is the inconstant depth of the oblique slots.

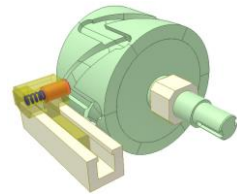

Barrel cam for 180 deg. rotation 1a

<http://youtu.be/SzoF0VMtc7w>

Pull and release green slider to let yellow barrel cam turn 180 deg.

Blue spring forces pink pin towards the cam. Key factor is different depths of the cam grooves.

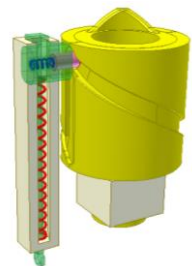

Barrel cam for 180 deg. rotation 2a

<http://youtu.be/l25QNREEYRM>

Pull and release blue frame to let green barrel cam linearly reciprocate and turn 180 deg. for each stroke.

Blue spring forces orange pin towards the cam. Key factor is different depths of the cam grooves.

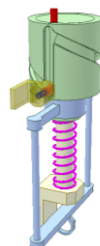

Successive 90 deg. rotation 1a

<https://youtu.be/NTauqMFgvgl>

Input: green slider of helical groove linearly reciprocating.

Output: four glass squares turning 90 deg. one after another.

The pink pin of each square moves in the said helical groove.

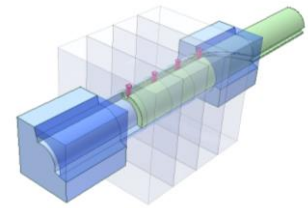

Successive 90 deg. rotation 1b

https://youtu.be/RGSfgha2_8o

Input: yellow slider of helical groove linearly reciprocating.

Output: four glass squares turning 90 deg. one after another.

The green pin of each square moves in the said helical groove.

Reds spring pins are for positioning the squares after each 90 deg. rotation. In combination with the internal circular groove in each square they also prevent axial displacement of the squares.

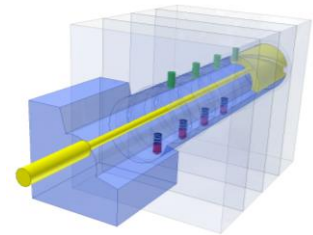

In/out motion by twist 1

<https://youtu.be/VTmT0-4UmdA>

The pink cam has prismatic joint with blue body.

Twist the knurled grip clockwise to get in/out motion of the cam.

The zero slope portions of the cam keep the cam stable at its in/out positions under the action of the green spring.

The disadvantage of this mechanism: the in/out stroke length can not be large because the cam pressure angle must be kept small enough for easy motion.

The mechanism can be applied to twist pens.

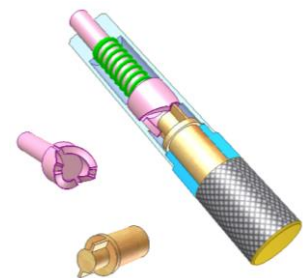

In/out motion by twist 2

<https://youtu.be/-WDzM7-Vt94>

The pink rod has prismatic joint with blue body.

Twist the knurled grip clockwise to get out motion of the rod.

Twist the knurled grip back to get in motion of the rod.

The red pin fixed to orange core slides in the slot of green barrel cam.

The green spring and suitable shape of the cam slot keep the rod stable at its in/out positions.

The disadvantage of this mechanism: the in/out stroke length can not be large because the cam pressure angle must be kept small enough for easy motion.

The mechanism can be applied to twist pens.

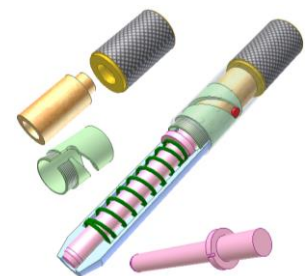

In/out motion by twist 1b

<https://youtu.be/o37bbdT97NY>

The pink cam has prismatic joint with blue body.

The green cam is stationary. Its profile is opposite to the one of the pink cam.

Twist the knurled grip clockwise to get in/out motion of the pink cam. The zero slope portions of the cams keep the pink cam stable at its in/out positions under the action of the green spring.

Adding the green cam makes the in/out stroke length of the pink cam increased two times while the cam pressure angle are kept unchanged.

The mechanism can be applied to twist pens.



Wedge screw mechanism

https://youtu.be/bKYT0ym_rJ0

Input: pink screw.

Output: blue pins.

Turn the screw to get in/out motion of the pins.

The yellow part plays at the same time roles of a nut and a wedge.

$$S = L \cdot \cos(\gamma)$$

L: lead of the pink screw.

γ : angle between motion directions of the yellow and blue parts.

S: displacement of the blue parts in 1 rev. of the screw.

This mechanism can be used in fixtures.

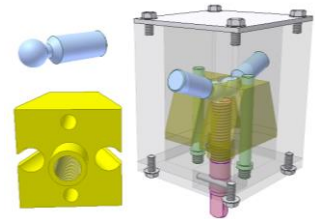

Linkage of 2 sliders, 2 conrods

<https://youtu.be/qwm8loo1GQ4>

The mechanism particularity: there is no crank rotating on fixed bearing. A conrod (in violet) plays role of the crank.

It can be used as a self-balanced clamp for two workpieces if the gap between red pin and its slot is large enough.

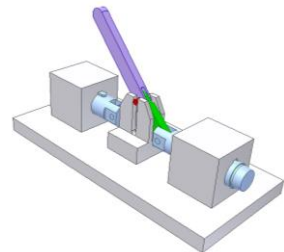

6.3. Screws

Nut – slider joint

<http://youtu.be/myXnrBTGqH8>

This joint enables the orange nut to push and pull the brown slider while turning on the green fixed screw.

There is no need of the third part for the joint.

Key factor is the eccentric hole on the slider.

Force transmission area between the nut and the slider in pushing is larger than in pulling.

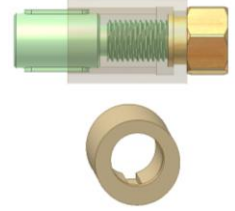

Screw mechanism 1

<http://www.youtube.com/watch?v=zIAm3MVDAc0>

The mechanism consists of 2 movable links and 3 screw joints.

In 1 rev of the blue crank:

The nut's displacement $s = h_3 \cdot (h_1 - h_2) / (h_3 - h_2)$

The nut's rotation $\phi = (h_1 - h_2) / (h_3 - h_2)$ revs.

h_1 : pitch of the screw joint of the blue screw and the base.

h_2 : pitch of the screw joint of the blue screw and the green nut.

h_3 : pitch of the screw joint of the green nut and the base.

h_1 , h_2 , h_3 carry negative sign in case of left-handed thread and vice-versa.

For this case, $h_1 = 2$, $h_2 = 3$ and $h_3 = 4$ so $s = -4$ $\phi = -1$

Wanted s and ϕ values can be obtained by combination of appropriate h_1 , h_2 , h_3 and the thread direction.

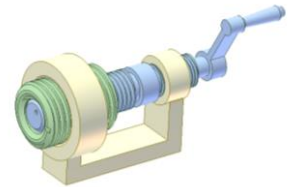

Screw mechanism 2

<http://www.youtube.com/watch?v=0P-ao2F3jvc>

The mechanism consists of 2 movable links, 2 screw joints and 1 revolution joint.

In 1 rev of the blue crank:

The nut's displacement $s = -h_2 \cdot h_3 / (h_3 - h_2)$

The nut's rotation $\phi = -h_2 / (h_3 - h_2)$ revs.

h_2 : pitch of the screw joint of the blue screw and the green nut.

h_3 : pitch of the screw joint of the green nut and the base.

h_2 , h_3 carry negative sign in case of left-handed thread and vice-versa.

For this case, $h_2 = 3$ and $h_3 = 4$ so $s = -12$, $\phi = -3$

Wanted s and ϕ values can be obtained by combination of appropriate h_2 , h_3 and the thread direction.

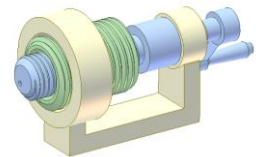

Screw mechanism 3

<http://www.youtube.com/watch?v=Jhzh7CLr0cQ>

The mechanism consists of 2 movable links, 2 screw joints and 1 prismatic joint.

In 1 rev of the blue crank:

The nut's displacement $s = (h_1 - h_2)$.

h_1 : pitch of the screw joint of the blue screw and the base.

h_2 : pitch of the screw joint of the blue screw and the green nut.

h_1 , h_2 carry negative sign in case of left-handed thread and vice-versa.

For this case, $h_1 = -2$ and $h_2 = 3$ so $s = -5$.

Wanted s values can be obtained by combination of appropriate h_1 , h_2 and the thread direction.

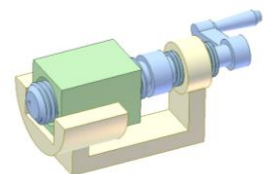

Nut-screw differential mechanism 1

<http://youtu.be/-ZN6Kj3sXtc>

Thread on the orange screw is M5x0.8 (right hand).

External thread on the green knob is M8x1.25 (right hand).

The orange screw moves $1.25 - 0.8 = 0.45$ mm during 1 rev. of the knob.

It is possible to reduce this difference by choosing appropriate leads.

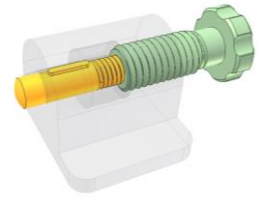

Nut-screw differential mechanism 2

<http://youtu.be/jbF4Jujf4Os>

Thread on the orange screw is M5x0.8 (right hand).

External thread on the pink nut is M8x1.25 (right hand).

External thread on the green knob is M14x1.5 (right hand).

The brown pin is for preventing rotation of the pink nut.

Turn the orange screw for rough adjustment: the orange screw moves 0.8 mm for 1 rev. of the screw.

Turn the green knob for fine adjustment: the orange screw moves $1.5 - 1.25 = 0.25$ mm for 1 rev. of the knob.

It is possible to reduce this difference by choosing appropriate leads.

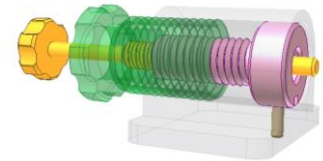

Study of worm-worm drive 2

<http://youtu.be/owAL3oaNPqE>

Input: small worm, 1 start, lead: t_1 , pitch diameter: D_1

Output: large worm, 2 starts, lead: $t_2 = 2.t_1$, pitch diameter: $D_2 = 2.D_1$. It has prismatic joint with the base.

The output moves t_1 in 1 rev. of the input.

The output can be of circular grooves in stead of thread.

The large worm can be replaced with a rack (like in adjustable spanners).

If the large worm has cylindrical joint with the base, the output motions (linear and rotary) are unstable.

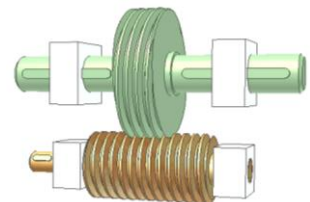

Study of worm-worm drive 3

<http://youtu.be/OXi0K14okV0>

Input: blue crank to which is fixed a small worm (1 start, lead: t_1 , pitch diameter: D_1).

Output: large worm, 2 starts, lead: $t_2 = 2.t_1$, pitch diameter: $D_2 = 2.D_1$

The output moves t_2 in 1 rev. of the input.

The small worm can be replaced with a cylinder of circular grooves or with a rack.

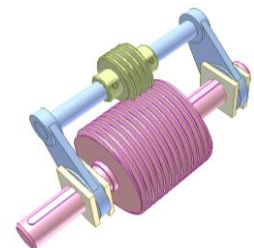

Nut-screw drive 1a

<http://youtu.be/jod9BKuNCoY>

Input: green screw of lead t_1 .

Orange nut has circular grooves (not helical).

The blue slider has revolution joint (rolling bearing in practice) with the nut so the latter can rotate in it. The screw axis and the axis of the slider hole are not concentric so the nut can roll on the screw to reduce the friction.

Output: blue slider moving t_1 in 1 rev. of the input.

If the nut has helical grooves (threaded) the output motion will be unstable subject to the nut - screw friction.

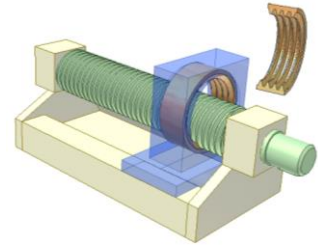

Nut-screw drive 1b

<http://youtu.be/ty8oRhk9q6U>

Nut-screw drive developed from "Nut-screw drive 1a"

Input: yellow screw of lead t_1 .

Orange nuts have circular grooves (not helical).

The blue slider has revolution joints with the three nuts so the latter can rotate in it. The nuts are arranged symmetrically around the screw axis to increase load capacity of the drive and reduce screw bending.

Output: blue slider moving t_1 in 1 rev. of the input.

For a real drive see:

<https://www.youtube.com/watch?v=iPkoGug-oC0>

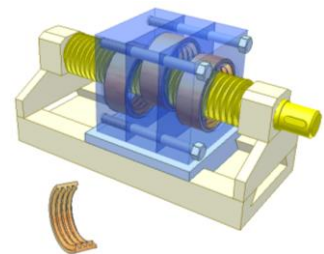

Nut-screw drive 1c

<http://youtu.be/pCoy03fPPMo>

Input: blue pulley having eccentric hole for orange nut.

The pulley rotates in bearings concentric with the screw axis.

Orange nut has circular grooves (not helical).

The blue pulley has revolution joint (rolling bearing in practice) with the nut so the latter can rotate in relation with the pulley.

The nut rolls on the screw to reduce the friction.

Output: green screw of lead t_1 fixed to popcorn slider moves t_1 in 1 rev. of the input.

If the nut has helical grooves (threaded) the output motion will be unstable subject to the nut - screw friction.

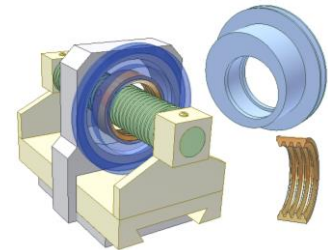

Nut-screw drive 2

<http://youtu.be/UrR1ZUSUMJQ>

Input: grey pulley having tilted hole to create revolution joint (rolling bearing in practice) with orange nut.

Output: green screw of lead t_1 .

Nut has two internal circular rings that roll on the screw.

In 1 input rev. the screw moves t_1 .

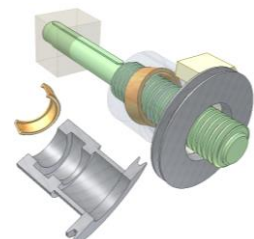

Study of planetary worm-worm drive 1a

<http://youtu.be/WUagFpDKz54>

Input: blue crank.

Internal gear (tooth number $Z_2 = 76$) is stationary. Orange worm of circular grooves is fixed to the orange gear (tooth number $Z_1 = 16$). Block of orange worm and gear rotates idly on eccentric shaft of the blue crank. The orange worm can roll on the pink large worm thus reduces the friction.

Output: pink worm (lead = t_2) moving linearly an amount of t_2 in 1 revolution of the input.

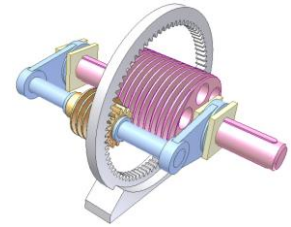

Study of planetary worm-worm drive 1b

http://youtu.be/FQo9_QIBki0

Input: blue crank.

Internal gear (tooth number $Z_2 = 76$) is stationary. Yello worm (lead = t_1) is fixed to the yellow gear (tooth number $Z_1 = 16$). Block of yellow worm and gear rotates idly on eccentric shaft of the blue crank. The yellow worm can roll on the pink large worm thus reduces the friction.

Output: pink worm (lead = $t_2 = 2 \cdot t_1$) moving linearly an amount of S in 1 revolution of the input.

$$S = t_2 + (Z_2/Z_1) \cdot t_1$$

Increase number of yellow blocks for high load capacity.

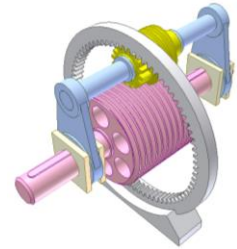

Study of planetary nut-screw drive 1a

<http://youtu.be/DX1T0aczS6Q>

Input: yellow pulley.

Internal gear (35 teeth) is stationary. Pink nut is fixed to the pink gear (30 teeth). The nut of circular grooves rotates in eccentric hole (in pink) of the yellow pulley. The nut can roll on the screw thus reduces the friction.

Output: green screw (lead = t_2) moving linearly an amount of t_2 in 1 revolution of the input.

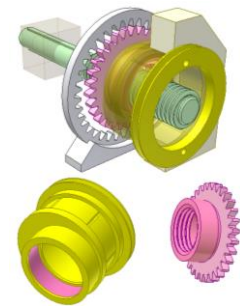

Study of planetary nut-screw drive 1b

<http://youtu.be/uNV4S-KsvbQ>

Input: yellow pulley.

Internal gear (35 teeth) is stationary. Pink nut is fixed to the pink gear (30 teeth). The nut (lead = t_1) rotates in eccentric hole (in pink) of the yellow pulley. The nut can roll on the screw thus reduces the friction.

Output: green screw (lead = $t_2 = t_1$) moving linearly an amount of S in 1 revolution of the input.

$$S = t_2 + (Z_2/Z_1) \cdot t_1$$

If no grey internal gear, the output motion depends on the friction between the nut and the screw. If no friction the screw does not move.

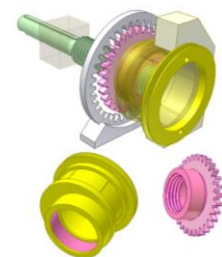

Differential screw mechanism

<http://youtu.be/YFzov0PbjpM>

Input: yellow gear shaft.

Output: blue slider.

Orange gear creates a helical joint with green screw.

The video shows 3 motions of the blue slider: backward, fast backward and slow forward corresponding 3 positions of the grey lever carrying 3 pink pinions for controlling the orange gear rotation.

Braking device for the orange gear is not shown.

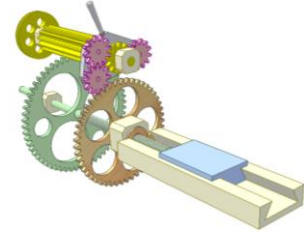

Adjustable tool for lathes

<http://www.youtube.com/watch?v=l2f6AjUdNBw>

A lathe turning tool in a drill rod is adjusted by a differential screw. When turning the red nut, it is advanced and the tool is retracted simultaneously. The resultant displacement of the tool is very small, $(t_2 - t_1)$ mm in 1 rev. of the nut.

t_2 : pitch of the nut external thread.

t_1 : pitch of the nut internal thread.

The threads are right hand.

The tool is clamped by a setscrew after adjusting.

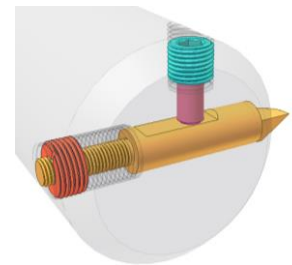

Nut-Screw drive 1

<http://www.youtube.com/watch?v=q1DcU5txgJk>

The input nut fixed to the green button is translated.

The output screw is rotated.

The screw is made by twisting a metal strip.

The mechanism has been used for winding cameras.

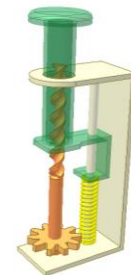

Tensioner 1a

http://www.youtube.com/watch?v=TvsxYUj_6wI

The screws have opposite-hand threads.

Measure to keep the orange screw from rotation is not shown.



Tensioner 1b

<http://www.youtube.com/watch?v=G2Urv8dambI>

The screws have opposite-hand threads.

Flats on the screw ends restrain the orange screw against rotation.

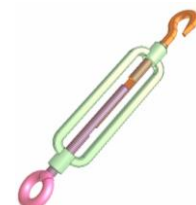

Tensioner 2

<http://www.youtube.com/watch?v=bwpbab9XITg>

The green nut has opposite-hand threads on its internal and external cylinder surface. The mechanism occupies less longitudinal space than “Tensioner 1a”:

http://www.youtube.com/watch?v=TvsxYUj_6wI

Measure to keep the orange screw from rotation is not shown.



Precise height adjustable table

<http://www.youtube.com/watch?v=PRYNpNA8elw>

A measuring table goes up and down very slowly for many turns of the input bevel gear. All the threads has the same hand. Their pitches are t_1 mm and t_2 mm. In 1 revolution of the green bevel gear the table moves $(t_2 - t_1)$ mm.

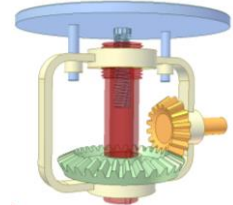

Half nuts for lathes

<http://www.youtube.com/watch?v=yqYd2-52R5U>

The haft nuts get engaged with the leadscrew by the blue slot face cam. The mechanism is used for turning threads.

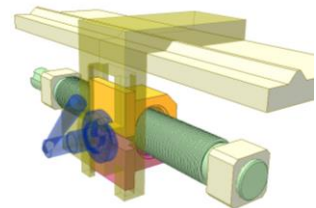

Lathe tailstock 1

<http://youtu.be/pgsJJl5-zow>

Use the yellow lever to release or tighten the green spindle.

Turn the orange screw to move the spindle that has a hole with internal thread. At right end position of the spindle, the screw pushes the blue center for its removing.

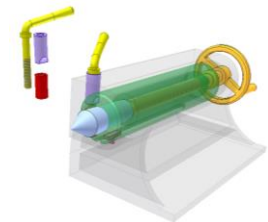

Lathe tailstock 2

<http://youtu.be/gGVdUasdM9A>

Use the violet lever (eccentric) to release or tighten the green spindle.

Turn the orange screw to move the spindle. The pink nut is fixed to the tailstock house. The blue round nut is for removing the center.

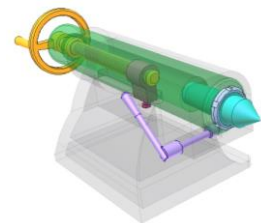

Lathe tailstock 3

<http://youtu.be/Sf-WVtx5mio>

Use the yellow lever to release or tighten the green screw-spindle.

Turn the orange nut-wheel to move the spindle.

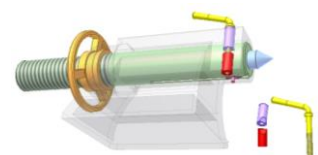

Twin screw mechanism 1

<http://youtu.be/gxNnRek2tzM>

Input: pink gear making two green screws rotate in the same direction. Threads of the screws have opposite helical directions. Violet lever carrying two half nuts contacts with one of the two screws. The contact is controlled by a toggle mechanism of pink lever, blue spring and two blue stoppers.

Output: yellow slider having linear reciprocating motion. Its length and position can be adjusted by setting positions of the two blue stoppers.

Thread form must be square in order not to cause radial force that tends to push the nuts from the screws.

In case two green screws rotate in opposite directions, threads of the screws have the same helical direction.

Created only on computer, this mechanism needs to be verified in practice.

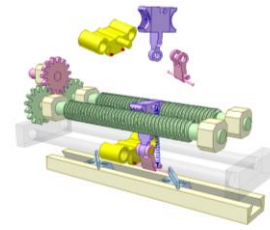

Twin screw mechanism 2

<http://youtu.be/GBq--a5prRc>

Input: pink gear making two green screws rotate in opposite directions. Threads of the screws have the same helical direction.

Violet lever carrying two half nuts contacts with one of the two screws. The contact is controlled by a toggle mechanism of blue spring, brown and blue levers and two green stoppers.

The violet lever has a red spherical pin that contacts the brown lever groove.

Output: yellow slider having linear reciprocating motion. Its length and position can be adjusted by setting positions of the two green stoppers.

Thread form must be square in order not to cause radial force that tends to push the nuts from the screws.

Created only on computer, this mechanism needs to be verified in practice.

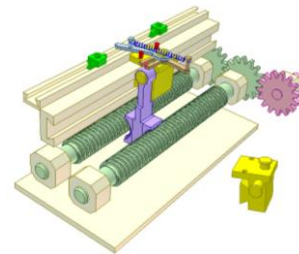

Double ratchet mechanism

<https://youtu.be/LL5YynZnmh4>

Input: red crank.

Output: violet slider moving one time in six revolutions of the input.

Violet screw is fixed to the violet slider.

Violet screw engages with the thread of the blue nut - ratchet wheel.

Two green pawls are fixed to each other.

Outer green pawl can engage with the yellow ratchet wheel.

Inner green pawl can engage with the blue ratchet wheel.

In one revolution of the input, yellow ratchet wheel turns 1/12 revolution and pauses.

In every six revolutions of the input, the blue ratchet wheel turns together with the yellow ratchet wheel only one time, when the outer green pawl is in the deeper tooth grooves (in red).

When the outer green pawl is not in the deeper tooth grooves, the inner green pawl does not contact the blue ratchet wheel.

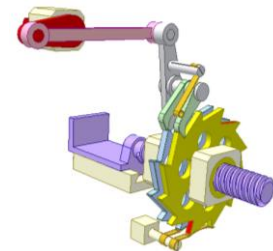

6.4. Belts and cables

Cable drive 1

http://youtu.be/MDsTRN_a9hs

The brown cable is wound 1 rev. around the pink pulley. Its two ends are fixed to the green slider.

It is simplest way to convert rotation to translation and vice versa (as a rack-pinion drive).

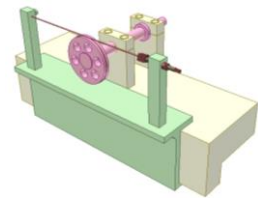

Cable drive 2

<http://youtu.be/d2qLx8KYK1g>

The pink slider moves twice faster than the blue one.

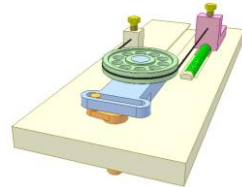

Cable drive 3

<http://youtu.be/cbENtxMiRk0>

The blue slider carries two orange identical pulleys.

A point (middle) of the lower cable branch is fixed (immobile).

The upper branch is fixed to the pink slider, velocity of which is double the one of the blue slider.

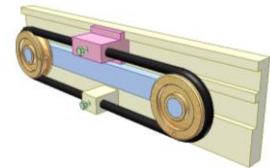

Cable drive 4

http://youtu.be/Kwobt2n7_HY

The blue and brown cables each wraps 1 rev. round the orange pulley of two radii (R and r , R is larger than r).

The pulley has a revolution joint with the blue slider.

Two ends of the blue cable are fixed to the yellow slider.

Two ends of the brown cable are fixed to the immobile base.

Velocity ratio between the yellow slider (V_y) and the blue one (V_b):

$$V_y/V_b = (R + r)/r$$

For this case $R = 2r$ so $V_y = 3V_b$

If $R = r$ then $V_y = 2V_b$

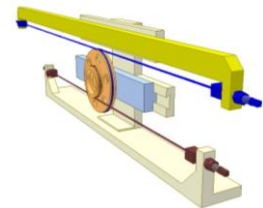

Cable drive 5

<http://youtu.be/JkqfoA5LXR4>

The green pulleys are identical. The yellow pulleys are identical.

The blue cable with two fixed ends wraps round the green pulleys.

The black cable with two fixed ends wraps round the yellow pulleys.

Four vertical cable branches must be parallel.

The pink slider has vertical translational motion (with or without guideway).

Eccentric arrangement between the green pulleys and the yellow pulleys in vertical direction is possible.

This mechanism was used for drawing parallel horizontal straight lines.

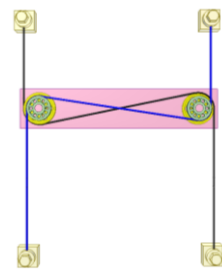

Cable truck

<http://youtu.be/fks4ziPym18>

Turn the yellow crank to move the pink truck on a straight railway.
The yellow pulleys have two round grooves for wrapping the black and blue cables.

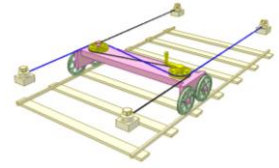

Cable drive 6

<http://youtu.be/uju7Ut2n9fM>

The yellow pulleys have 1 round groove.
The green pulley has 2 round grooves.
The black cable wraps on upper yellow pulley and the green one.
The blue cable wraps on lower yellow pulley and the green one.
All pulleys have the same contact (with the cables) diameter.
The pink slider have vertical translational motions (with or without guideway).

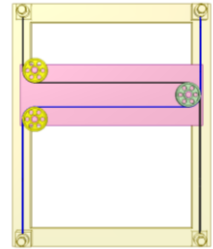

Cable drive 7

<http://youtu.be/e4Wgiyk02U4>

The yellow and green pulleys are identical.
The blue cable with two ends fixed to the pink slider wraps on the green pulleys.
The black cable with two ends fixed to the pink slider wraps on the yellow pulleys.
The pink slider has vertical translational motion (with or without guideway).

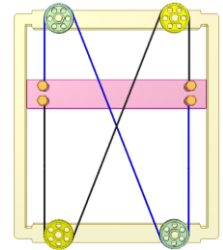

Cable drive 8

<http://youtu.be/BpkbSWNvvSA>

The yellow pulleys are identical.
The blue endless cable wraps on all the pulleys.
Each of two pink bars is fixed to the cable at two points.
The bars have vertical translational motions in opposite directions (with or without guideway).

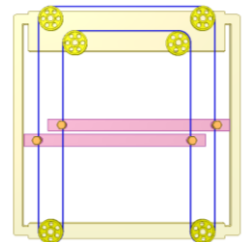

Cable drive 9A

http://youtu.be/5Ft3_hqnt30

Mechanism for vertical moving a working platform (in blue).
The blue cables carrying weights for platform equilibration. Turn the pink pulley to make the platform go up and down (through red cable).

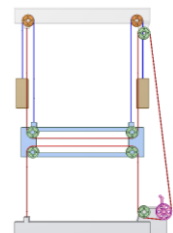

Cable drive 9B

http://youtu.be/7_0lsm10qDs

Mechanism for vertical moving a working platform (in blue).

The platform tends to get lowest position.

The blue cables carry contraweights. Pull the red cable to make the platform go up and fix it at desired position (fixing measure is not shown).

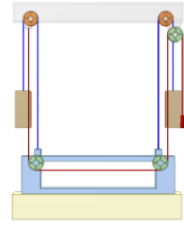

Cable drive 9C

<http://youtu.be/NofhU1uEXJ4>

Mechanism for vertical moving a working platform (in blue).

There are four cables. The ends of each cable are fixed to the platform and to the contraweight.

The pink and yellow pulleys have two cable grooves.

Turn the yellow pulley to make the platform go up and down (through red and cyan cables).

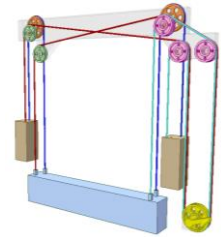

Cable drive 10

<http://youtu.be/hzsfHbpbQls>

Mechanism for vertical moving a working platform (in blue).

Only one endless cable is used.

The green, pink and orange pulleys are identical.

The green pulley and the yellow one are fixed together (two couples).

Turn one of the yellow pulleys to make the platform go up and down.

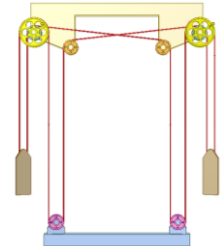

Cable drive 11

<http://youtu.be/0KAmDnGBVJc>

Turn the yellow crank to move the green trolley along a horizontal rail.

The orange platform, while moving horizontally, also moves vertically due to the black and blue cables.

Angle between its rectilinear trajectory and the horizontal line is 45 deg.

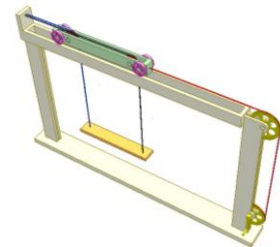

Cable drive 12

<http://youtu.be/g9hmQTGQTO4>

This is a good way for mounting equilibratory weights to prevent jam of the pink slider.

Four cables are used. Each weight has two connected to it.

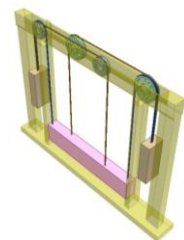

Cable telescopic frame

<http://youtu.be/ylnMEfrQWwA>

Turn the pink pulley to make the violet frame go up and down.

Each of the red and blue cables has one end fixed to the pink pulley, the other to the violet frame. The green pulleys are identical. The weight of the moving parts ensures the cable tension.

The verticality of some cable branches is not compulsory.

In case of horizontal arrangement it is possible to add a second similar cable system for return motion.

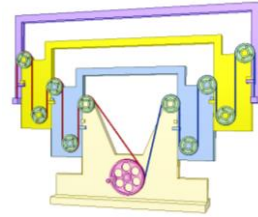

Cable drive 21

<http://youtu.be/R6fhA3ln8JU>

A simple way to convert reciprocating rotation to reciprocating translation.

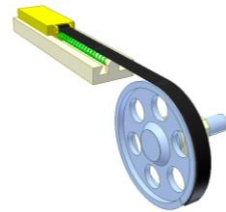

Cable mechanism

<https://youtu.be/-6tyx-ab3No>

Input: pink pulley.

Output: violet slider.

The pink and orange pulleys rotate twice faster than the yellow pulleys.

Use double-side timing belt instead of cable to eliminate the sliding in motion transmission.

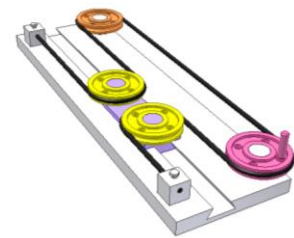

Linear friction clutch

<https://youtu.be/evDCn8u8aTk>

Input: one among two blue pulleys.

Output: yellow slider.

Use blue lever fixed to pink eccentric shaft to control the clutch.

The pink and orange eccentric shafts, violet and brown conrods create a double parallelogram mechanism. The yellow conrod helps the parallelogram mechanism overcome the dead point.

The blue lever has three positions.

Neutral position: the violet bar does not allow two green plates of green sliders press black belt to the yellow slider so the latter does not move.

Other positions: the violet bar allows one among two green plates of green sliders press black belt to the yellow slider so the latter moves thanks to friction force cause by red springs. The moving direction depends on which branch of the belt is engages with the yellow slider.

Positioning device for the control lever is not shown.

Because of inertia and sliding the yellow slider can't stop instantly.

Want to reverse the motion automatically? Please see:

<http://youtu.be/iXbi7jod57Y>



7. Rotation to wobbling motion

Wobbling coin

<https://youtu.be/kv0V3QHPNCA>

Wobbling motion of a coin on horizontal plate.

A point on the coin periphery goes up down with decreasing amplitude and simultaneously rotates slowly around vertical axis of the plate.

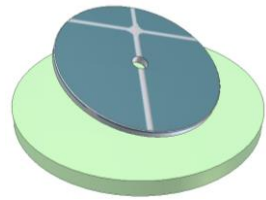

Wobbling and rotating motions 1

<https://youtu.be/75LzNyOkH5g>

Motions of two disks look similar but in fact totally different.

1. Brown disk (swashplate) is rotating. A point R on its periphery rotates. Its distance to the ground is constant. Its locus is a circle in the horizontal plane.

The brown disk is fixed inclinedly on a rotating shaft. See its application:

<http://www.youtube.com/watch?v=dafYYCBo4VU>

2. Blue disk is wobbling. A point W on its periphery goes up down, so its distance to the ground is varied. It is possible to consider that point W oscillates around horizontal axis with period P_w . This axis rotates around vertical axis with a period P_r . Locus of point W is of saw-tooth shape.

The video shows case when $P_r = 6.P_w$. The locus of point W has 5 saw-teeth.

If $P_r = P_w$, the wobbling motion becomes rotating one (like case of the brown disk).

If $P_r = 0$, locus of point W is a circular arc in vertical plane.

For creating wobbling motion a crank of inclined portion is used. See applications of wobbling motion:

<http://www.youtube.com/watch?v=dygqFaX8srU>

http://www.youtube.com/watch?v=eT_rtLEcjlS

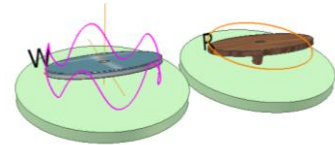

Wobbling disk mechanism 1a

<http://www.youtube.com/watch?v=59WtZtcHV6M>

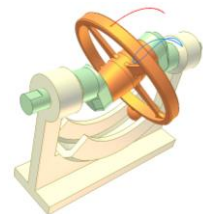

Wobbling disk mechanism 1b

<http://www.youtube.com/watch?v=z1OxclWpmck>

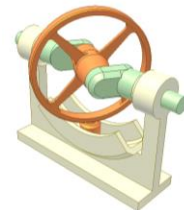

Wobbling disk mechanism 1c

<http://www.youtube.com/watch?v=lqCKkvmwLoI>

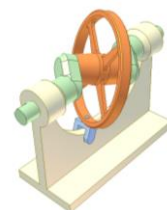

Wobbling disk mechanism 1d

<http://www.youtube.com/watch?v=MqrIDAT-Agg>

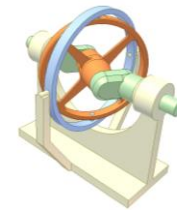

Application of wobbling disk mechanism 1

<http://www.youtube.com/watch?v=4MshdQtQFeA>

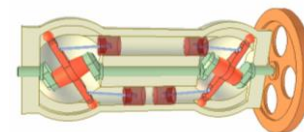

Wobbling disk mechanism 4

<http://youtu.be/K7WahB1FD3g>

This mechanism has two degrees of freedom.

Two independent rotary motions are assigned to pink crank and green disk.

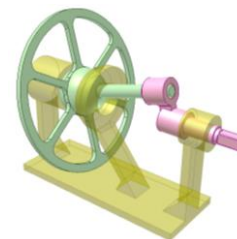

Wobbling disk mechanism 2

<http://www.youtube.com/watch?v=oBqxuEjRnDM>

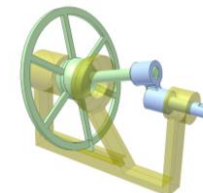

Application of wobbling disk mechanism 2

<http://www.youtube.com/watch?v=dygqFaX8srU>

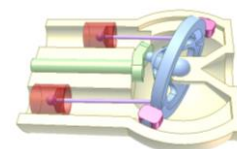

Wobbling disk mechanism 5

<http://youtu.be/k2CVF-L1W2l>

Input: pink crank.

The orange propeller performs a complicated motion that may find application for mixing machines.

There is a considerable backlash in the gear drive.



Wobbling disk mechanism 6

<http://youtu.be/VpSXJkPBbQ4>

Input: pink crank.

A vertical wall prevents orange disk from rotating. The orange disk rolls on two cone surfaces.

The mechanism may be used for pumps. The arrows show fluid flows. An amount of fluid is sucked into the pump during its first revolution and discharged during the next revolution.

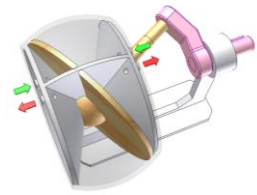

Wobbling disk mechanism 3

<http://www.youtube.com/watch?v=TqBDpLp3RJg>

Steam engine of disk piston.

Steam is admitted alternately on either side of piston.

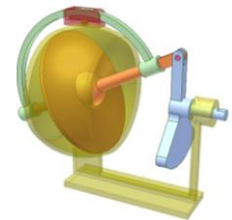

Ceilling fan 1a

<http://youtu.be/YFyX6fxkvpA>

Two inputs: rotor carrying yellow propeller and pink crank (two electric motors).

Axes of all revolution joints of the pink crank and the green frame are concurrent.

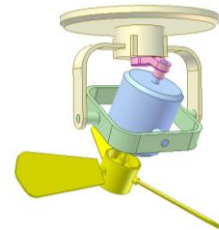

Ceilling fan 1b

<http://youtu.be/WN4ATS2XcVU>

Input: rotor carrying yellow propeller (electric motor).

Pink gear is fixed to the pink crank that is mounted idly on the fan base.

Motion is transmitted from the yellow propeller to the pink crank through two gear drives. Axes of revolution joints of the pink crank and the green frame are concurrent.

Use worm drives for large transmission ratio (for example: two worm drives and one spur gear drive).



8. Altering linear motions

8.1. Bars, wedges and cams

Transmission of linear displacement 1a

http://youtu.be/pz_7UZRnMZM

Angle of the pink twin equal crank is $A = 90$ deg.. The crank length is a . Angle between sliding directions of the runways is $B = 90$ deg.. Transmission ratio of linear displacement between the blue slider and the yellow one is 1. When the blue bar move regularly, so does the yellow.

Position of the crank bearing can be arbitrary.

Transmission ratio of 1 can not be kept if A differs from B

Advantage over rack-pinion drive: high precision of transmission at low manufacture cost.

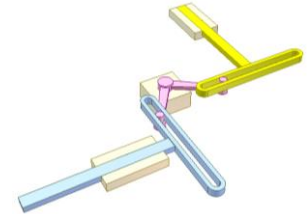

Transmission of linear displacement 1b

<http://youtu.be/XnZQS6qhtaE>

Angle of the orange twin equal crank is $A = 60$ deg.. The crank length is a . Angle between sliding directions of the runways is $B = 60$ deg. Transmission ratio of linear displacement between the blue slider and the yellow one is 1. When the blue bar move regularly, so does the yellow.

Position of the crank bearing can be arbitrary.

Transmission ratio of 1 can not be kept if A differs from B .

Advantage over rack-pinion drive: high precision of transmission at low manufacture cost.



Transmission of linear displacement 2

<http://youtu.be/Bz4anYbkXmY>

Angle of the pink twin arm is $A = 90$ deg..

Angle between sliding directions of the runways is $B = 90$ deg..

Transmission ratio of linear displacement between the blue slider and the yellow one is not 1.

When the blue bar move regularly, the yellow not.

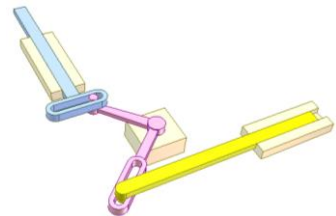

Transmission of linear displacement 3a

<http://youtu.be/HnGQCIs07r0>

Angle of the orange twin equal crank is $A = 60$ deg.. Angle between sliding directions of the runways is $B = A = 60$ deg.

The crank pivot center must be on the bisector of sliding directions of two sliders.

Transmission ratio of linear displacement between the blue slider and the yellow one is 1.

When the yellow bar move regularly, so does the blue.

Advantage over rack-pinion drive: high precision of transmission at low manufacture cost.



Transmission of linear displacement 3b

<http://youtu.be/e51sMAdGS40>

An embodiment of "Transmission of linear displacement 3a"

$A = B = 90$ deg.

Orange parts have revolution joints with the sliders and prismatic joints with the pink arm.

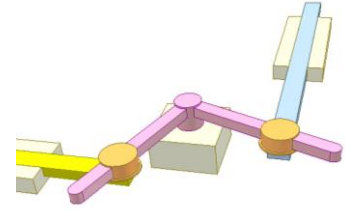

Transmission of linear displacement 4

<http://youtu.be/BwYzRrFOt9E>

Angle of the pink twin arm is $A = 80$ deg..

Angle between sliding directions of the runways is $B = A = 80$ deg..

The crank pivot center must be on the bisector of sliding directions of two sliders.

For the pink crank, the distance between planes, that contact with the violet rollers, and the crank's pivot centerline must be equal to roller's radius.

Transmission ratio of linear displacement between the blue slider and the yellow one is 1.

When the yellow bar move regularly, so does the blue.

Red arrow represents resisting force.

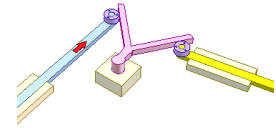

Transmission of linear displacement 5

<http://youtu.be/9b6bNjXsBqo>

Angle of the pink twin arm is $A = 90$ deg..

Angle between sliding directions of the runways is $B = 90$ deg..

Transmission ratio of linear displacement between the blue slider and the yellow one is not 1.

When the yellow bar move regularly, the blue not.

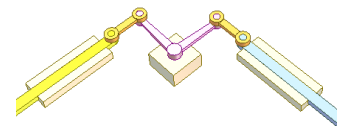

Transmission of linear displacement 6

<http://youtu.be/qFjCFQ15ff8>

Transmission ratio of linear displacement between the blue slider and the violet one is not 1.

When the blue slider move regularly, the violet not.

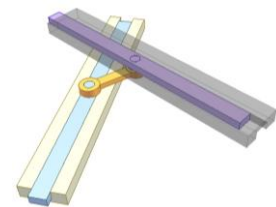

Transmission of linear displacement 7a

http://youtu.be/VVRj9mh_JEc

Angle between two sliding directions of the blue slider is A deg.

Angle between sliding directions of the runways is $B = (180 - 2.A)$ deg.

Transmission ratio of linear displacement between the pink slider and the blue one is 1. When the pink slider moves regularly, so does the blue.

With other value of B , the transmission ratio differs from 1.

In substance it is a translating cam mechanism.

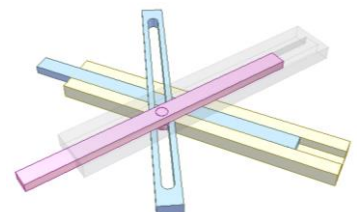

Transmission of linear displacement 7b

<http://youtu.be/45DxLld4ZX0>

Angle between two sliding directions of the blue slider is A deg. Angle between sliding directions of the runways is $B = (180 - 2.A)$ deg. Transmission ratio of linear displacement between the pink slider and the blue one is 1. When the pink slider moves regularly, so does the blue.

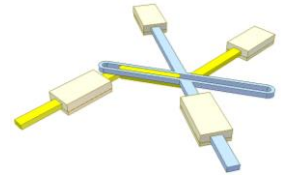

It is an embodiment of “Transmission of linear displacement 7a”.

The pin of the pink slider is replaced by a rectangular key that creates an angle A with the sliding direction of the yellow slider.

With other value of B, the transmission ratio differs from 1.

In substance it is a wedge mechanism.

Transmission of linear displacement 8

<https://youtu.be/yPJMS7dXLM>

Yellow, violet, blue and green links create a parallelogram.

Centers of revolute joints of blue/green links creates similar triangles.

Center A of revolute joint of pink slider and center B of upper revolute joint of green link trace two lines (in red and in green) intersecting at center O of fixed revolute joint of violet link.

Angle AOB is equal to the one between two arms of blue or green link.

If A goes towards (or apart from) O, so does B.

If A moves regularly, so does B.

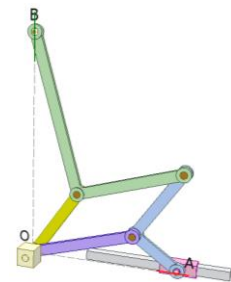

Linkage for linear motions 1

<http://youtu.be/-P8eOBkzuYw>

Back mechanism:

Input: pink slider. Opposite sliders move in opposite directions with the same speed.

Front mechanism:

Input: violet slider. Opposite sliders (in orange) move in the same direction with different speeds.

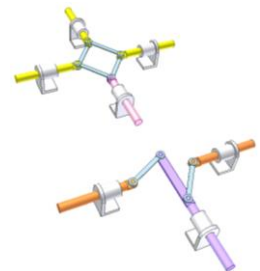

Mechanism for increasing stroke length 1

<http://youtu.be/MbqEe-l3Z7M>

Input: blue slotted slider linearly reciprocating with constant stroke length.

Output: orange slider linearly reciprocating with adjustable stroke length.

Yellow slider has revolution joint with green slotted bar.

Adjust position of the yellow slider on the blue slider to get various stroke lengths of the output.

$$L_o = L_i \cdot (a/x)$$

L_i : input stroke length

L_o : output stroke length

x : pivot center distance between pink and yellow sliders in vertical direction.

a : distance from pivot center of the pink slider to sliding line of the orange slider in vertical direction.

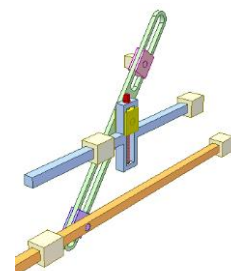

Mechanism for increasing stroke length 2

<http://youtu.be/4G6mSwPguK4>

Input: blue bar linearly reciprocating with constant stroke length.

Output: grey bar linearly reciprocating with adjustable stroke length.

Yellow slider has revolution joint with pink slider.

Adjust position of the pink slider on the fixed runway to get various stroke lengths of the output.

$$L_o = L_i \cdot (a+x)/x$$

L_i : input stroke length

L_o : output stroke length

a : distance between sliding lines of blue bar and grey bar.

x : distance from pivot center of the pink slider to sliding line of the blue bar.

The adjustment can be performed when the mechanism is running.

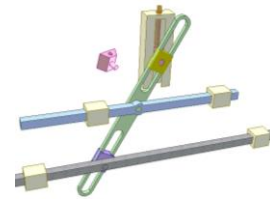

Linkage for linear motions 2

<https://youtu.be/rrnqCnMQIRw>

Grey, blue and pink runways are fixed.

Yellow conrods have the same length.

Angle between grey and blue runways can be adjusted.

Angle of grey/blue runway with pink runway are equal.

Input: green slider.

Output: violet slider.

Distances between green and violet sliders to point O are always equal.

Speeds of the input and output are equal.

The mechanism has an unstable position when the yellow conrods are perpendicular to grey and blue runways. At this position when green slider moves towards point O, violet slider may move away from point O.

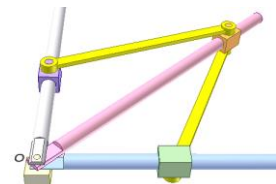

Three sliders of radial synchronic motion

<https://youtu.be/86qnMnOtpoM>

Green cylinder controls the radial motion of pink slider.

Two blue sliders move synchronously with the pink one thanks to yellow sliders and violet conrods.

Pink and blue sliders have the same velocity.

So do the yellow sliders.

However, velocity of yellow sliders differs from the one of pink and blue sliders.

Weakness of this mechanism:

- Driving forces for the blue sliders are not in line with the slider moving directions.
- Gaps in the joints may reduce the motion accuracy of the blue sliders.

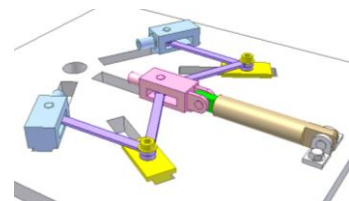

Lazy tong 1

<http://youtu.be/Zm-4kJLdRcM>

Input: pink slider.

Output: orange link.

Small longitudinal force on the input causes large one on the output (around 3 times in this case). The input and output move in opposite directions.

The mechanism finds application in lazy tong riveter:

<https://www.youtube.com/watch?v=7D7ECCps0h4>

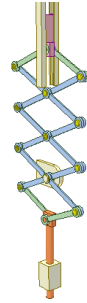

Lazy tong 2

<http://youtu.be/UniRkbt0LOY>

Input: pink slider.

Output: violet link.

Short input motion gives a long output one (around 3 times in this video). The input and output move in opposite directions.

The green link is for keeping the violet link direction unchanged.

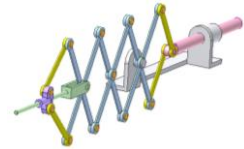

Lazy tong 3

<http://youtu.be/cML0xKSmTPM>

Input: pink slider.

Output: violet link.

Short input motion gives a long output one (around 4 times in this video). The input and output move in the same direction.

The gears on yellow links are for keeping the violet link direction unchanged.

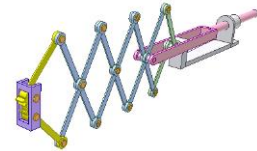

Double scissor mechanism

<https://youtu.be/zYfj9d2adgg>

It is a serial connection of two scissor mechanisms to get large transmission ratio.

Brown and grey sliders are immobile.

Transmission ratio of blue lower mechanism: $T_b = 2$

Transmission ratio of pink upper mechanism: $T_p = 5$

Total transmission ratio: $T = T_b \cdot T_p = 2 \cdot 5 = 10$

Two scissor mechanisms are connected via green slider pin.

Input: red slider driven by yellow piston.

Violet slider moves ten times faster than the red one.

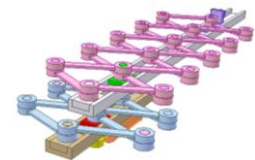

Increasing force caused by a spring 2

<https://youtu.be/JWk3dk2m8h4>

Force (black arrow) needed for moving blue part is around 4.5 times of the force (red arrows) from green spring due to yellow slotted lever. This mechanism is for case when using larger spring is not suitable.

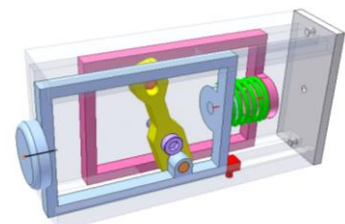

Wedge mechanism 1
<http://youtu.be/IS5ivukXRrg>

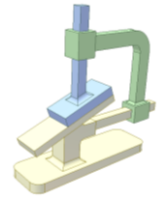

Wedge mechanism
<http://www.youtube.com/watch?v=GeAEU2fGYKY>

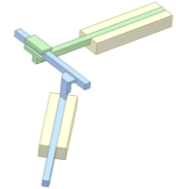

Wedge mechanism 2
<http://youtu.be/6nWhE4ExegM>

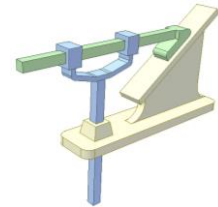

Wedge mechanism 3
<http://youtu.be/9MTK6NNBCyc>

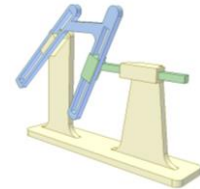

Wedge mechanism 4
<http://youtu.be/A5a2mZNIHjw>

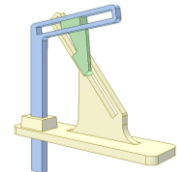

Wedge mechanism 5A
<http://youtu.be/oP4NIjh8SIs>

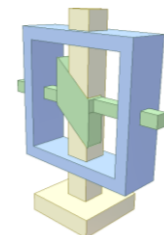

Wedge mechanism 5B
<http://youtu.be/2Zc6MzhJZi4>

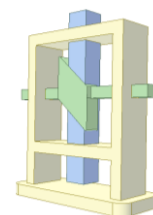

Wedge mechanism 6

<http://youtu.be/vARgErlmtr0>

A construction measure for increasing course of the horizontal wedge.

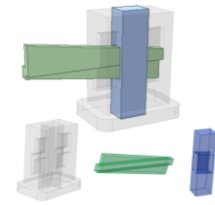

Wedge mechanism 7

<http://youtu.be/laQA6cUrkaU>

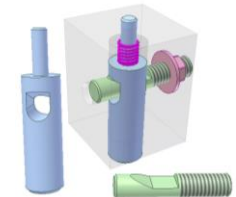

Wedge mechanism 8

<http://youtu.be/c3ep2XyCAow>

Input is the green horizontal bar. The stroke length of the blue vertical bar can be adjusted by choosing appropriate position of the red slider (altering the wedge angle of the mechanism).

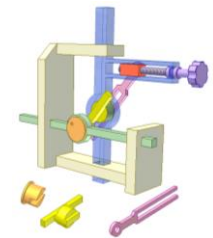

Wedge mechanism 10

<http://youtu.be/C5DWm0ab7BU>

The revolution joint between pink nut and green slider does not have kinematic significance. It is only for redeeming manufacture errors.

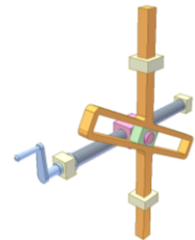

Wedge mechanism 13

<http://youtu.be/f1FofjOrrP0>

Combination of screw and wedge mechanisms gives precise small displacement of a slider (in blue).

The yellow fixed wedge has slopes in two directions for positioning the pink ball. The spring is located inside the slider to reduce slider's length.

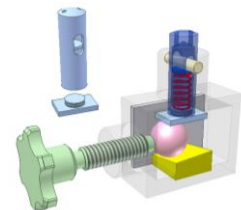

Wedge mechanism 14

<http://youtu.be/XYjx0u75HNs>

Combination of screw and wedge mechanisms gives precise small displacement of a table (in blue).

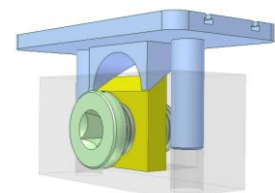

Wedge mechanism 15

<http://youtu.be/DIGLkp8Csg>

Hole diameter measuring device.

The object to be verified is the green. The violet fixed wedge transfers horizontal displacement into vertical one which can be read out on the indicator.

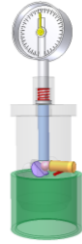

Wedge mechanism 18

<http://youtu.be/3u9swq3XDSg>

A bit of Morse taper tail can be removed easily by a wedge.

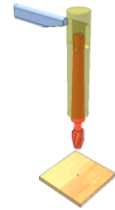

Wedge mechanism 29

<https://youtu.be/oEJgmXyrp8c>

The height of the mechanism can be regulated by blue nut.

Green cylindrical washers allow pink screw change its obliquity.

The weight of upper wedge maintains the contact between two wedges.

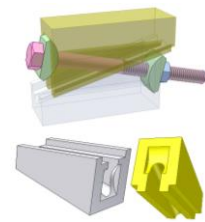

Wedge mechanism 30a

<https://youtu.be/9StqsULenWM>

Input: wedge bar linearly reciprocating.

Output: pink follower linearly reciprocating.

This mechanism is simple with runways of circle sections.

Its assembly is easy as shown in the video last scene.

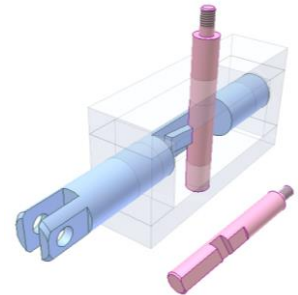

Wedge mechanism 30b

<https://youtu.be/7BRB3mD5p2c>

Input: wedge bar linearly reciprocating thanks to pink piston rod.

Output: yellow follower linearly reciprocating. Its motion includes fast stage and slow one.

Last scene of the video shows key dimensions of this mechanism.

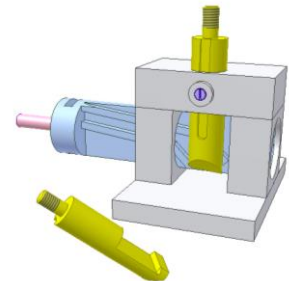

Linear motion reverser

<https://youtu.be/-jRHF8YwI>

It is a combination of two wedge mechanisms.

Yellow button and blue pin move in opposite directions.

Pink wedge consists of two portions fixed together by a sunk screw.

Cross holes on grey base, yellow button and blue pin are for assembling purpose.

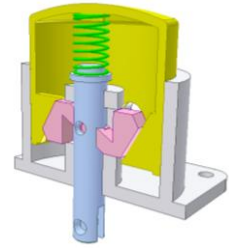

Translational cam

<http://www.youtube.com/watch?v=f6ThkL0fQe8>

A measure to increase follower stroke while unchanged pressure angle.

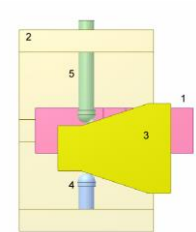

Stroke-multiplying mechanism

<http://www.youtube.com/watch?v=XDe0WAmb5aw>

The second slot in the blue base helps double stroke of the yellow output slider. The green input slider is driven by a cam (not shown).

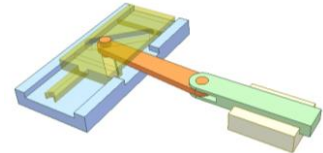

Translating cam mechanism TTr1

<http://youtu.be/n6fXu9OAb6I>

The follower has a twin arm carrying two rollers that contact both sides of the cam rim of constant thickness A . No backlash if clearance between the rollers = A .

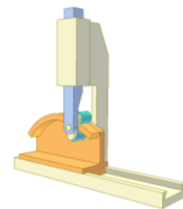

Translating cam mechanism TTr2a

<http://youtu.be/uMkATPVaA9Y>

The green input cam reciprocates. The blue follower rests during cam's right to left stroke and moves during return. The pink and yellow plates help the roller move clockwise.

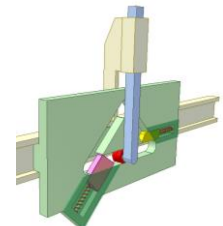

Translating cam mechanism TTr2b

http://youtu.be/nPcV9fF_h8A

The green input cam reciprocates. The blue follower rests during cam's right to left motion and moves during return.

The inconstant depth of the horizontal groove helps the red pin move clockwise.

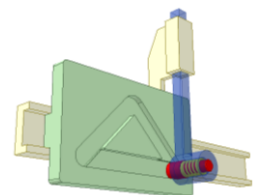

Translating cam mechanism TTr3

<http://youtu.be/Bmp3OJiJQbw>

The green input cam reciprocates. The blue follower moves at the ends of forth and back strokes.

The various grooves' depths enable the red pin to move clockwise.

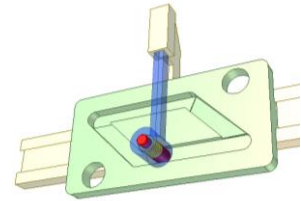

Double translating cam mechanism 1

<http://youtu.be/1aQMPifguc4>

The input pink slider has linear reciprocating motion. Due to the violet T-shaped lever carrying two rollers and the slots on the orange and yellow plates, the output blue slider moves with dwell at right end of the input stroke.

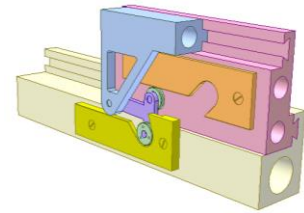

Double translating cam mechanism 2

http://youtu.be/HK7u_ncfScM

The input green slider has linear reciprocating motion. Due to the red pin moving in three slots of the parts, the output pink slider moves with dwell in the middle of the input stroke.

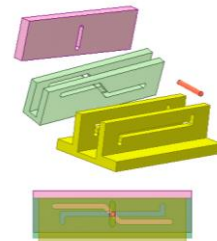

Translating cam mechanism 4

<http://youtu.be/C053HbNN5-U>

If the cam pitch line is a symmetric zigzag, a rhomb-shaped pin can be used for the cam and follower contact to increase load capacity.

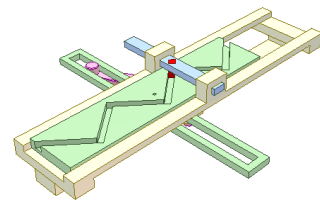

Increasing force without changing direction

<https://youtu.be/-4eTxFOncs0>

Input: yellow slider. Axial force F_2 is applied to it.

Output: green slider. Axial force F_1 represented by the pink spring is applied to it.

Red balls (circularly arranged, but here only two are shown) are in contact with inner cone of the yellow slider, outer cones of the green slider and the grey shaft.

$$F_2 = F_1 \cdot (2 \cdot \tan(A) \cdot \tan(B)) / (\tan(A) + \tan(B))$$

A: vertex angle of the outer cones.

B: vertex angle of the inner cone.

Because B is chosen small, F_2 is considerably smaller than F_1 . For example:

A = 60 deg.; B = 5 deg. then $F_2 = F_1/6$

Advantage: It can be applied for rotary parts.

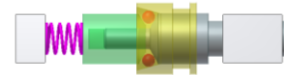

Increasing force without changing direction 2

<https://youtu.be/ZMz0cDxVAz8>

Input: blue wedge. Vertical force F_1 is applied to it.

Output: green slider. Axial force F_2 is applied to it .

Brown roller contacts with the blue wedge.

Pink rollers contact with the green wedge.

$$F_2 = F_1 \cdot \frac{\tan(B)}{\tan(A)}$$

A: angle of the blue wedge.

B: angle of the green wedge.

In this video $A = 30 \text{ deg.}$; $B = 60 \text{ deg.}$ then $F_2 = 3.F_1$

If B is smaller and A is larger, F_2 can be considerably larger than F_1 .

For example: $A = 15 \text{ deg.}$; $B = 75 \text{ deg.}$ then $F_2 = 14.F_1$



Transmission of linear displacement 10

<https://youtu.be/kp00q1w-Qpo>

Input: pink slider reciprocating. It has a pin that moves in the oblique straight groove at back of horizontal yellow slider.

Output: blue slider. It has a pin that moves in the front groove the yellow slider. The front groove shape controls the output motion.

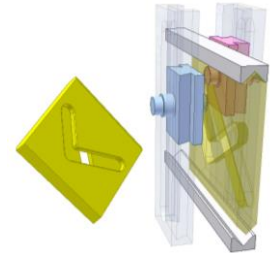

Helical joint reverser of linear motion

<https://youtu.be/4YuaUuRISHq>

Input: green outer tube of right hand helical slot.

Output: blue inner tube of left hand helical slot.

They move longitudinally in opposite directions with the same velocity.

The helical slots have the same lead.

Red pin moves in both slots.

Pink circular slider rotates in the base circular groove.

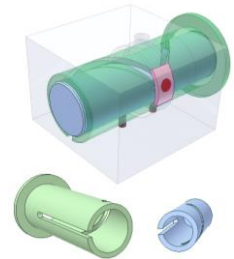

Transmission of linear displacement 11

https://youtu.be/e4dM_q342iM

Input: pink slider reciprocating. Its yellow pin moves in a groove of blue barrel cam.

Output: green slider. Its violet pin moves in the second groove the blue cam. The second groove shape controls the output motion.

The second groove is deeper and narrower than the first one.

The violet pin is longer and thinner than the pink one.

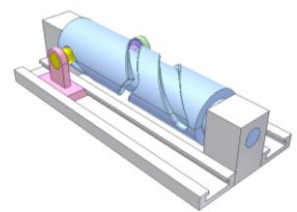

Transmission of linear displacement 12

<https://youtu.be/4AgscLYzYik>

Input: green rack of 45 deg. oblique teeth reciprocating. It makes blue gear and barrel cam angularly reciprocate.
Output: pink slider. Its violet pin moves in the cam groove.
The groove shape controls the output motion.

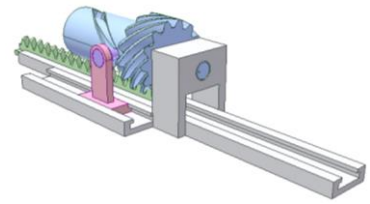

Wedge mechanism 31a

<https://youtu.be/LTD3-ZEH0vk>

Angles of pink angular rod are 135 deg.
Two blue shafts move in opposite directions with the same speed.
All the joints are prismatic.

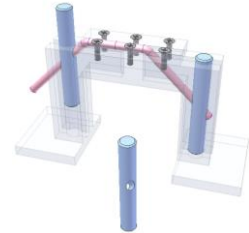

Wedge mechanism 31b

<https://youtu.be/988ZbHQptw>

Wedge angles of orange slider are 45 deg.
Two blue shafts move in opposite directions with the same speed.
All the joints are prismatic.
Green springs maintain contacts between the wedge and the shafts.
In principle this mechanism can be applied for scales (last scene of the video). Weakness of scales: large friction in the prismatic joints and force parameters between the two springs must be identical.

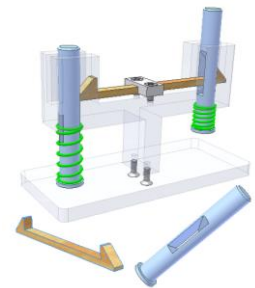

8.2. Gear drives

Application of rack pinion mechanism 1

http://www.youtube.com/watch?v=qdCOBf_qIGk

Velocity of the green slider is double the one of the violet slider

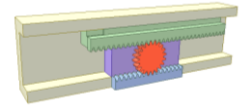

Gear rack drive for increasing stroke length 1

<https://youtu.be/LvasE387M70>

Input: red slider of V_r velocity. It carries block of two gears.

Tooth numbers: Z_2 and Z_1 . (Z_2 is larger than Z_1)

Output: green slider of V_g velocity.

Brown rack is stationary. Green rack is fixed to the green slider.

$$V_g = V_r \cdot ((Z_1 + Z_2) / Z_1)$$

Here $Z_2 = 2 \cdot Z_1$ so $V_g = 3 \cdot V_r$

If $Z_2 = Z_1$, $V_g = 2 \cdot V_r$

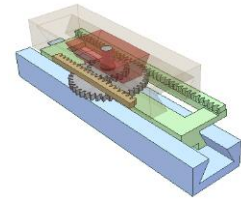

Gear rack drive for increasing stroke length 2

<https://youtu.be/l18nqMpyBaY>

Input: red slider of V_r velocity carrying orange gear. Pink rack is fixed to the red slider.

Output: yellow slider of V_y velocity. Yellow rack is fixed to the yellow slider.

Brown rack is stationary. Green rack is fixed to green slider that carries blue gear.

The gears are of the same tooth number.

The orange gear is in mesh with the brown and green racks.

The blue gear is in mesh with the pink and yellow racks.

$$V_y = 3 \cdot V_r$$

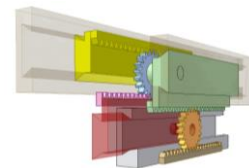

Gear rack drive for increasing stroke length 3a

<https://youtu.be/6dQ9IPshlbs>

Input: pink slider of V_p velocity carrying orange gear.

Output: yellow slider of V_y velocity. Yellow rack is fixed to the yellow slider.

Green rack is fixed to green slider of V_g velocity that carries blue gear.

Brown and grey racks are stationary.

The gears are of the same tooth number.

The orange gear is in mesh with the brown and green racks.

The blue gear is in mesh with the grey and yellow racks.

$$V_y = 4 \cdot V_p$$

$$V_g = 2 \cdot V_p$$

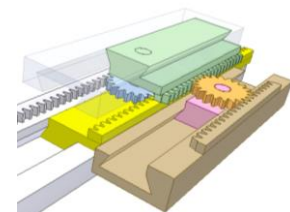

Gear and rack drive for increasing stroke length 3b

<https://youtu.be/fBdCevF8z8w>

It is a structural embodiment of “Gear and rack drive for increasing stroke length 3a”.

Input: orange slider of V_o velocity.

Output: pink slider of V_p velocity.

$$V_p = 4 \cdot V_o$$

Velocity of blue slider $V_b = 2 \cdot V_o$

Violet and green gears have the same tooth number.

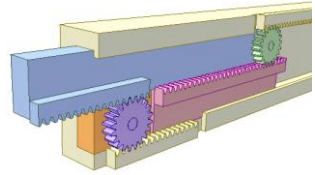

Mechanical telescopic cylinder 1

<https://youtu.be/jWxARpHUVrg>

Input: yellow screw driven by a electric motor.

Violet frame carrying pink pinions that engage with stationary grey racks and with green racks fixed to green frame.

Green frame carrying orange pinions that engage with violet racks fixed to the violet frame and with blue racks fixed to blue frame.

The yellow screw – violet nut drive makes the violet frame goes up down.

The green frame moves two times faster than the violet frame.

The blue frame moves three times faster than the violet frame.

Front part of the mechanism is cut-off for easy understanding.

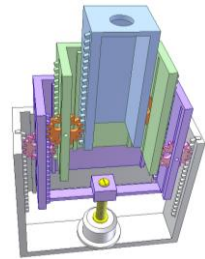

Telescopic pole 1

<https://youtu.be/LOuUUBhOgZY>

Hold the brown handle, press pink lever and pull green tube. Yellow tube automatically move forward. Release the pink lever for positioning the green and yellow tubes at new position.

The yellow tube moves twice faster than the green tube thanks to belt drive and two pins (in red and in green).

The two pins are fixed to the belt.

The green pin is fixed to the brown handle.

The red pin is fixed to the yellow tube.

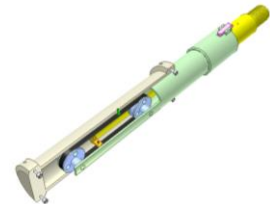

Telescopic pole 2

<https://youtu.be/Ta5lypFRBZM>

Hold the brown handle, press pink lever and pull green tube.

Yellow tube automatically move forward. Release the pink lever for positioning the green and yellow tubes at new position.

The yellow tube moves twice faster than the green tube thanks to gear (in red) and two rack drive.

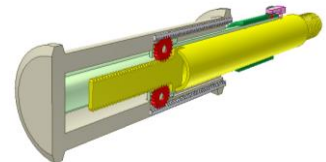

Application of rack pinion mechanism 3

<http://www.youtube.com/watch?v=aF8vagao6CM>

Changing direction of a rectilinear motion

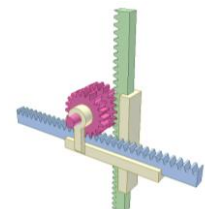

Transmission of linear displacement 9

<http://youtu.be/hiEq-MAgpM0>

One slider is the driver and moves regularly. In general the driven slider moves irregularly.

However there are exceptions.

For example, the video shows a case where the sliders move regularly, transmission ratio is 1. Sliding directions are perpendicular to each other. The assembly enables a position of the mechanism where the gear cranks and the runways create a rectangle.

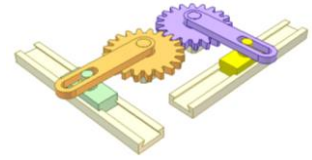

Rack-Rack transmission 1

<http://www.youtube.com/watch?v=x1loh0bysM0>

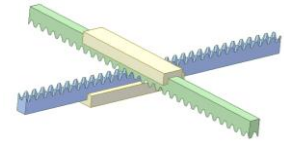

Rack-Rack transmission 2

<http://www.youtube.com/watch?v=ad9rl5sb-u8>

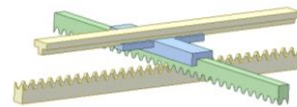

Rack-Rack transmission 3

<http://www.youtube.com/watch?v=Ew9q6uQfZwY>

Tooth shape: rectangular.

Tooth inclined angle $\beta_1 = 0$ deg., $\beta_2 = 45$ deg.

Angle between rack moving directions: $\gamma = 45$ deg.

Displacement relation: $s_2 = s_1 \cdot \cos\beta_1 / \cos\beta_2 = 1.41s_1$

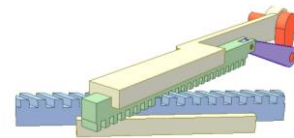

Rack-Rack transmission 4

<http://www.youtube.com/watch?v=p2Pf1NVVhNY>

Tooth directions on the two gear parts of the violet rack are opposite.

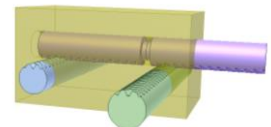

Rack-Rack transmission 5

http://www.youtube.com/watch?v=r_G9Ho3FCJ8

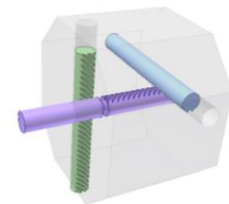

Increasing force caused by a spring 1

<https://youtu.be/h761XtjBsME>

Force (black arrow) needed for moving pink part is always double force (red arrows) from yellow spring due to the gear-rack drive. This mechanism is for case when using larger spring is not suitable.

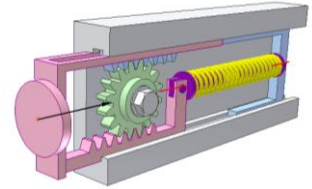

Increasing displacement caused by a spring 1a

<https://youtu.be/Bu1HgOHH7aE>

Pull orange pin to let blue frame move up under the action of green spring. A small deformation S of the green spring can give the blue frame a long displacement L .

Two yellow gears are fixed together.

Pink rack is in mesh with the small gear ($Z_p = 16$ teeth).

Blue rack is in mesh with the large gear ($Z_b = 18$ teeth).

$$L = S \cdot Z_b / (Z_b - Z_p)$$

If $(Z_b - Z_p)$ is small and Z_b is large, L can be very large.

In this video $L = 9S$

Two red pins play role of stoppers for the blue frame.

Push the blue frame to move it down.

For easy manufacture use cable drives instead of gear-rack ones.

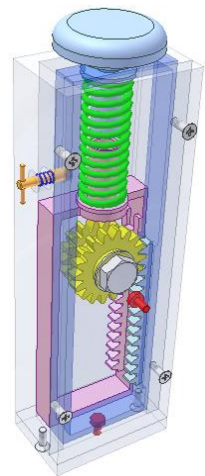

Increasing displacement caused by a spring 1b

<https://youtu.be/MLQq91mWdzk>

Blue frame is stationary.

Pull orange pin to let white box move up under the action of green spring. A small deformation S of the green spring can give the box a long displacement L .

Two yellow gears are fixed together.

Pink rack is in mesh with the small gear ($Z_p = 16$ teeth).

Blue rack is in mesh with the large gear ($Z_b = 18$ teeth).

$$L = S \cdot Z_b / (Z_b - Z_p)$$

If $(Z_b - Z_p)$ is small and Z_b is large, L can be very large.

In this video $L = 9S$

Red pin (fixed to the box) plays role of stopper for highest position of the box.

Push the box to move it down.

This mechanism gives a nearly constant driving force over a long travel without needing excessive wind-up of the spring.

For easy manufacture use cable drives instead of gear-rack ones.

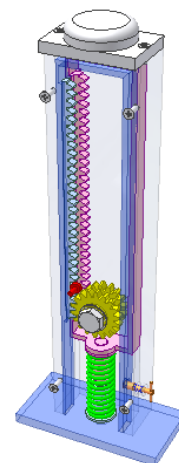

Mechanism for increasing stroke length 4

<https://youtu.be/EhBBxoh0kuQ>

Stroke length of violet slider: L_s (input)

Stroke length of yellow table: L_t (output)

$$L_t/L_s = \pi \cdot D/L$$

$$\pi = 3.142$$

D : rolling diameter of the green gear

L : helix lead of blue screw

Here $D = 40$ mm. $L = 40$ mm

$$L_t/L_s = 3.142$$

Lead angle of the blue screw should not less than 40 deg. for good efficiency.

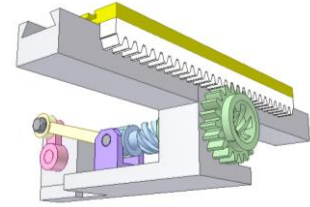

Gear - rack drive for changing direction of linear motion

<https://youtu.be/VjQuvIVZ3Lc>

Input: blue slider moving along a stationary runway thanks to grey cylinder.

Output: violet slider moving along a brown rotary runway. This motion can be performed even when the brown runway rotates.

Yellow round rack that can only move vertically is in mesh with two pink pinions.

Rotation of the brown runway is controlled by a motor (not shown) through the brown gear.

The mechanism can be used for controlling planar motion of a point that belongs to the violet slider based on the polar coordination system.

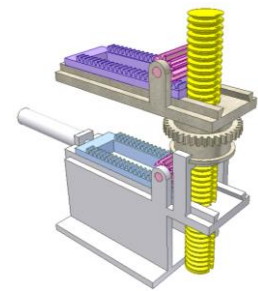

Two-worm drive 3

<https://youtu.be/QTRWOHi6bUs>

Two worms are identical and skew at 90 deg. angle.

Lead angle of the worm thread is 45 deg.

Start number of the worms: 3.

The worms are prevented from rotation.

The white runway is stationary.

Motion of green slider carrying orange worm makes blue slider carrying violet worm move.

Transmission ratio: 1

It can be called helix wedge mechanism.

Racks of oblique teeth have the same function:

<https://youtu.be/x1loh0bysM0>

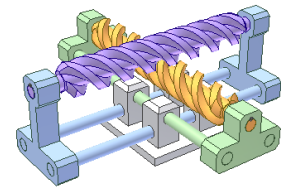

8.3. Chains, belts and cables

Chain drive 4A

<http://youtu.be/grMBzq0YHH0>

This mechanism is applied in lifting trucks. The violet fork moves two times faster than the green piston.



Chain drive 4B

<http://youtu.be/sEp-K6eyYz8>

The pink plate is driving.

The yellow frame moves two times faster than the pink one.

The sprockets have the same tooth number.

The lower red link of the chains is fixed to the base.

The upper red link of the chains is fixed to the yellow plate.

The mechanism can be used for telescopic sliding gate of two panels. See:

<http://www.youtube.com/watch?v=ASAxH51ify8>

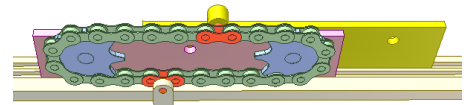

Chain drive 4C

http://youtu.be/CjVJk_0uYhE

The blue plate is driving.

The green plate moves two times faster than the blue one.

The violet plate moves two times faster than the green one or four times faster than the blue one.

The sprockets have the same tooth number.

The lower pink link of the front chains is fixed to the base.

The upper pink link of the front chains is fixed to the green plate.

The lower red link of the back chains is fixed to the blue plate.

The upper red link of the back chains is fixed to the violet plate.

The blue plate carries the front chain drive.

The green plate carries the back chain drive.

The mechanism can be used for telescopic sliding gate of three panels.

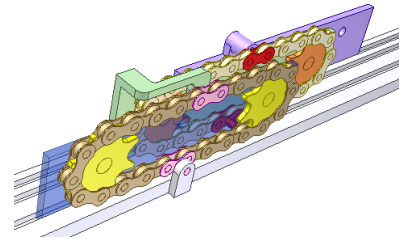

Transmission of linear displacement 8

http://youtu.be/HX_sU9Ye3VA

There are two belts. One belt end is fixed to pulley.

When the pink slider moves regularly, so does the yellow.

Transmission ratio of linear displacement between two sliders is 1 if two pulleys have the same belt contact diameter.

Spring may be cut down for the driving slider.

Angle between sliding directions is arbitrary.

This is similar to case of two rack-pinion mechanisms.



Transmission of linear displacement 13

<https://youtu.be/cC3QD0L0CIU>

Input: green slider. Its violet pin is fixed to blue belt

Output: pink slider.

Yellow slider moves in slot of the pink slider. Red pin, which has revolution joint with the yellow slider, is fixed to black belt.

When the green slider moves to the left, the pink slider performs reciprocating motion.

When the green slider moves to the right, the pink slider performs the same reciprocating motion.

Output motion can be adjusted by altering diameter of the small pulleys.

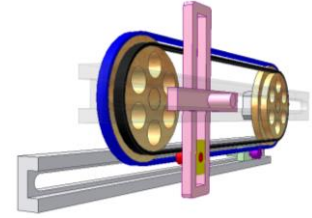

Mechanical telescopic cylinder 2

<https://youtu.be/yGxCs2ka7HQ>

Input: red screw driven by a electric motor.

Yellow frame carries orange pulleys. Their blue cables have points fixed to grey base and to green frame.

The green frame carries pink pulleys. Their black cables have points fixed to the yellow frame and to blue frame.

The red screw – yellow nut drive makes the yellow frame goes up down.

The green frame moves two times faster than the yellow frame.

The blue frame moves four times faster than the yellow frame.

Front part of the mechanism is cut-off for easy understanding.

The cable drives can be replaced with compact chain ones. See:

http://youtu.be/CjVJk_0uYhE

<https://youtu.be/sEp-K6eyYz8>

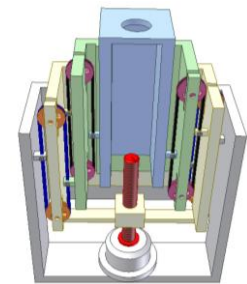

Cable drive 15

http://youtu.be/o2_0Ft6-Mq4

Pull and release the brown tow twice to let the green coulisse move forth and back. One end of the tow is fixed to the blue disk.

The orange spring ensures that the yellow ratchet wheel rotates in one direction. The circular slot on the blue disk and a pin on the case limit oscillating angle of the blue disk. A spiral spring (not shown) makes the blue disk rotate back when the tow is released. Another spring (not shown) always forces the pawl toward the ratchet wheel.

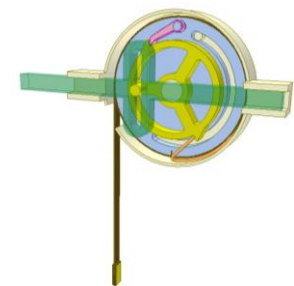

Cable drive for changing direction of linear motion 1

<http://youtu.be/LGEt58cRzlc>

Input: yellow sliders moving along X axes.

Output: green sliders moving along axes Y or Z that are skew to X axes. Skew angles are 90 deg.

X, Y and Z are parallel to Ox, Oy and Oz of a Cartesian coordinate system Oxyz (not shown) respectively.

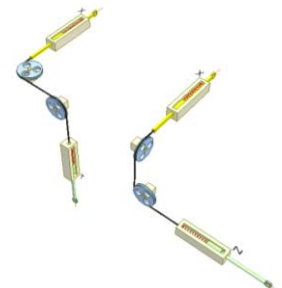

Cable drive for changing direction of linear motion 2

<http://youtu.be/6Xt5xkjQQnY>

Input: yellow slider moving along X axis.

Output: green slider moving along axis Y that is skew to X axis. Skew angle can be arbitrary, for this case is 45 deg.

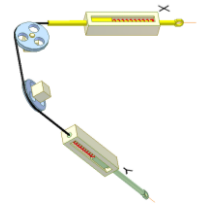

Cable drive for changing direction of linear motion 3

https://youtu.be/Gtpz_sVEdxA

Input: violet slider moving along a stationary runway thanks to grey cylinder.

Output: pink slider moving along a green rotary runway.

Axis of the cable vertical portion and axis of revolution joint of the movable runway are coaxial.

The cable twist does not affect motion transmission which can be performed even during the green runway rotation.

Rotation of the green runway is controlled by a motor (not shown) through the green gear.

The mechanism can be used for controlling planar motion of a point that belongs to the pink slider based on the polar coordination system.

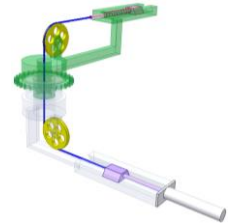

Cable drive 16a

http://youtu.be/1-M_5u_GqIE

W: weight of the load

P: pulling force for moving up the load.

Mechanical advantage: 2

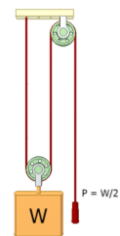

Cable drive 16b

<http://youtu.be/Zgg0ggGG7NU>

W: weight of the load

P: pulling force for moving up the load.

Mechanical advantage: 8

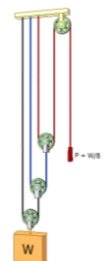

Cable drive 17a

<http://youtu.be/BrUh4IK8oY0>

W: weight of the load

P: pulling force for moving up the load.

Mechanical advantage: 2

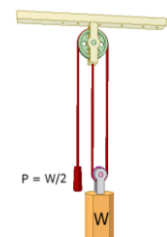

Cable drive 17b

<http://youtu.be/bCWv9xnyZi8>

W: weight of the load
P: pulling force for moving up the load.
Mechanical advantage: 8

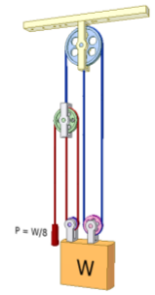

Cable drive 18a

<http://youtu.be/ybHgot0jbUc>

W: weight of the load
P: pulling force for moving up the load.
Mechanical advantage: 3

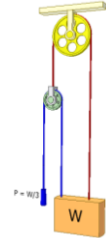

Cable drive 18b

<http://youtu.be/XVXbkQ-DZSs>

W: weight of the load
P: pulling force for moving up the load.
Mechanical advantage: 7

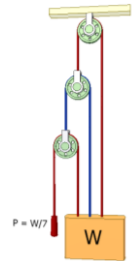

Cable drive 19

http://youtu.be/_1mvNDrcymk

W: weight of the load
P: pulling force for moving up the load.
Mechanical advantage: 4

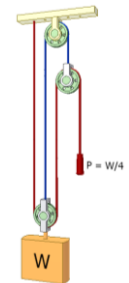

Cable drive 20

<http://youtu.be/MLWs-9-HqqU>

Four pulleys rotate independently.
W: weight of the load
P: pulling force for moving up the load.
Mechanical advantage: 4 (number of the cable branches that suspend the weight or twice number of movable pulleys)
Pulleys velocities:
 $V_g = 4V_b$
 $V_o = 3V_b$
 $V_p = 2V_b$
 V_g, V_o, V_p and V_b are velocities of green, orange, pink and blue pulleys, respectively.
Upper pulleys have the same rotation direction.
Lower pulleys have the same rotation direction, opposite to the one of the upper pulleys.



Bowden cable 1

<http://youtu.be/HhzvytVW1kk>

It is used to transmit a pulling force over short distances.

Input: yellow lever.

Moving direction of the violet output lever can be arbitrary.

The cable moves in green cable housing (a bended helical steel wire).

Orange inline hollow bolt (barrel adjuster) is for adjusting position of violet output lever.

Turning the bolt to the left means lengthening the cable housing relative to two grey fixed anchors and adjusting the output lever anticlockwise.

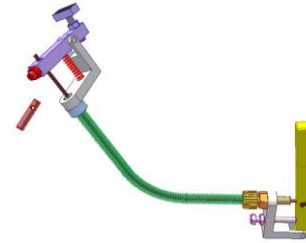

Bowden cable 2

<http://youtu.be/wWdTjjE4usA>

Input: pink button.

Output: blue pin.

The brown cable housing (a bended helical steel wire in practice) moves outside grey fixed cable.

Position of the pink button can be arbitrary in the space.

The mechanism is used to transmit a pushing force over short distances. It finds application for cameras

The displacement of the input can not be long.

The mechanism is cut off half for easy understanding.

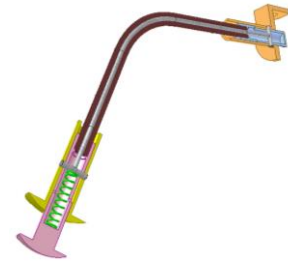

Drive for small linear movement

<http://youtu.be/86ZG5x2IEEM>

Movement directions between the input and the output can be arbitrary, even skew.

Regretably the animation can not show the vibration of the spring duct.

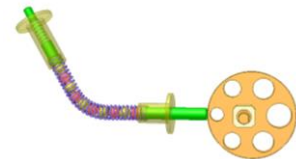

Reciprocating linear motion into continuous oneway one

<https://youtu.be/V-XMxIOIY0U>

It is developed from mechanism "Strip advancer 2"

<https://youtu.be/OWIAdRdb5RI>

Blue clutch (on the left) linearly reciprocates (its motion source is not shown). It makes pink clutch (on the right) move in opposite direction thanks to the cable drive.

Both clutches make orange toothed bar move to the left when they move to the left. Thus the bar move continuously to the left.

So this mechanism converts reciprocating linear motion into continuous oneway one.

Red springs always force the knives (in green and yellow) towards the bar.

The mechanism can work even in case the bar is not toothed thanks to the friction.

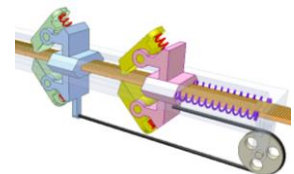

Increasing displacement caused by a spring 1c

<https://youtu.be/y5NGq2cgAe8>

Pull orange spring pin to let blue frame move up under the action of pink spring. A small deformation S of the pink spring can give the blue frame a long displacement L .

Two yellow pulleys are fixed together.

Red cable, two ends of which are fixed to the green frame, is wrapped around the smaller pulley of D_1 diameter.

Blue cable, two ends of which are fixed to the blue frame, is wrapped around the larger pulley of D_2 diameter.

$$L = S \cdot D_2 / (D_2 - D_1)$$

If $(D_2 - D_1)$ is small and D_2 is large, L can be very large.

In this video $L = 16S$

Because S is small, the force for moving the blue frame is nearly constant.

Violet pin play role of stopper for the green frame.

Push the blue frame to move it down.

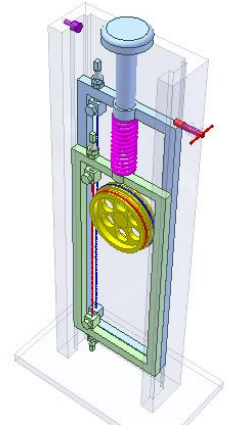

9. Converting reciprocating motion into continuous rotation

9.1. Converting reciprocating rotation into continuous rotation

Ratchet mechanism 10

<http://youtu.be/bj1UCX62Q-k>

This mechanism is used in hand powered electric torches to convert oscillatory motion into continuous rotation.

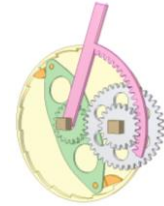

Ratchet mechanism 11

<http://youtu.be/GFcHRDEWYYo>

This mechanism is used for converting oscillatory motion into continuous rotation. Both go motion and back motion of the pink angle lever are useful.

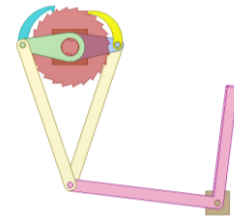

Cable drive 24

<http://youtu.be/BHapT2BMHC8>

A simple way to convert reciprocating rotation to continuous rotation. The orange contraweight tends to set the blue pedal at its highest position. Driving force can make the output link rotate only half way, the contraweight and inertia do the rest way.

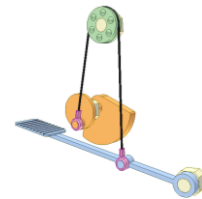

Belt drive 15

<http://youtu.be/-d8RDSBxHjY>

A simple way to convert oscillation to continuous rotation. Pedal down motion creates driving moment for the green shaft. During pedal up motion the green shaft rotates thanks to its inertia. Turning the green shaft at start-up is needed.

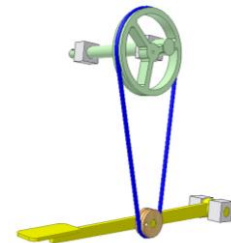

4 bar linkage for output rotation 1

<http://youtu.be/zjJGtwa2s1U>

A simple way to convert reciprocating motion to continuous rotation. Push and pull blue pedal by foot to rotate the orange output shaft. Driving force is applied to the conrod of a 4-bar linkage. Inertia helps to overcome dead positions. Turn the output shaft at start-up by hand when needed.

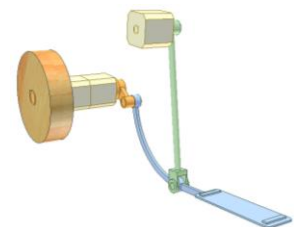

Foot driven mechanism for sewing machine

<http://www.youtube.com/watch?v=rzdP9OZeaRU>

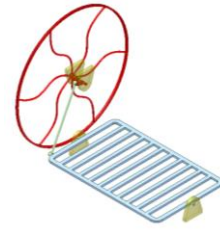

Pottery wheel 1

<http://youtu.be/P-xT0xrK6AE>

Operator's left foot pushes green lever to rotate the wheel. Continuous rotation is possible thanks to flywheel inertia. At starting use hands to turn the upper disk to overcome mechanism dead point when needed.

In another embodiment the green lever and the yellow conrod are removed. The operator rotates the flywheel directly by his foot (right or left).

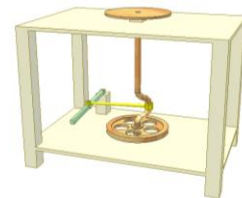

Man-powered grain mill

<https://youtu.be/9LhQBSy8ysE>

Input: pink levers operated by two people.

The lever oscillation is converted into rotation of orange upper mill thanks to 4-bar linkages (pink rockers, blue conrods and orange cranks).

Note: the fly-weights (four orange short cylinders) playing role of a flywheel.

This video was made based on a picture in a book published in 1588 as shown in last scene of this video.

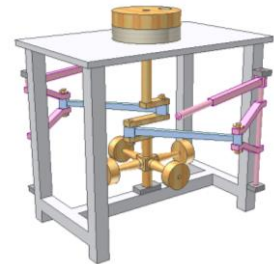

Hand powered machine

<https://youtu.be/w88ODRI2We8>

This is a machine from the very early 1500's.

The man rocks pink pendulum to rotate blue working shaft.

Green conrod, pink and yellow cranks create a 4-bar linkage.

Gear drive is for increasing velocity of the working shaft carrying a flywheel.

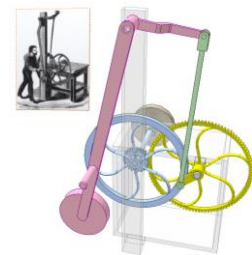

Railway hand car

<http://youtu.be/ZpnMvKxk4lw>

Swing green double lever to move the car via a 4 bar linkage and a gear drive.

Reverse of swinging means reversing the car.

Step on the red knob to operate a crank slider mechanism for braking.

This video is made based on G.S. Sheffield's invention in 1882.

Fore a real car see:

https://www.youtube.com/watch?v=rJg_9nxVc6A

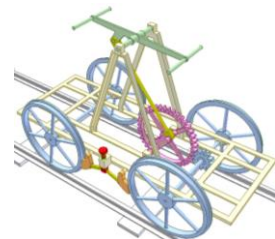

Spherical 4-bar linkage mechanism 4b

<https://youtu.be/xxBI9kF8LiY>

Input: pedal shaft (in grey).

Output: vertical shaft.

Two shafts are perpendicular to each other.

Axes of all revolution joints intersect at a common point.

The mechanism converts the input angular oscillation into the output continuous rotation.

The mechanism has two dead positions, when axes of all revolution joints are in a plane. The output inertia helps the mechanism overcome the dead points.

Orange weight keeps the pedal always at its upper position when not working.

Yellow disk cam and spring slider (in green) don't allow the mechanism to stop at its dead points to ease its starting.

In case without the weight and the cam, turn the output a little when starting, if needed.

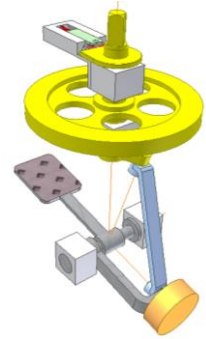

Spherical 4-bar linkage mechanism 4c

<https://youtu.be/WYCTav31Xbg>

It is an embodiment of the mechanism shown at:

<https://youtu.be/xxBI9kF8LiY>

for sitting operators.

Input: two pedals of coaxial horizontal rotary axes (in pink and violet).

Output: vertical shaft.

The mechanism converts the input angular oscillation into the output continuous rotation.

The mechanism has two dead positions.

The output inertia helps the mechanism overcome the dead points.

Yellow disk cam and spring slider (in green) don't allow the mechanism to stop at its dead points to ease its starting.

In case without the cam, turn the output a little when starting, if needed.

The gear system ensures opposite rotation directions of the two pedals.

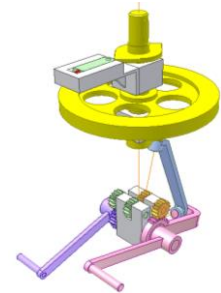

Foot powered washing machine

https://youtu.be/iW_3H3Qle4Q

It is a development of the mechanism shown at:

<https://youtu.be/WYCTav31Xbg>

for an India student project.

Washing tub is fixed to orange vertical shaft, speed of which is increased thanks to two belt drives.

The video show two working modes:

1. Tub oscillation: red stopper is set at its forwards position to limit motion of the pedals.
 2. Tub rotation: red stopper is set at its backward position (not to limit motion of the pedals).
- Disadvantage: vertical size is large.

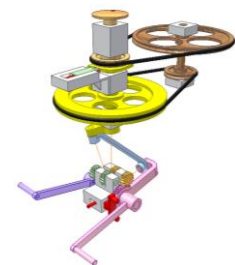

Foot powered washing machine 1

<https://youtu.be/eP9eY5tVsu8>

A 4-bar linkage (pink rockers, violet cranks and yellow conrods) is used for converting oscillation into continuous rotation.

Washing tub is fixed to the base. Washing cage is fixed to the violet cranks.

For easy start do not stop the machine at dead positions of the 4-bar linkage (where the violet cranks and the yellow conrods are in line).

This mechanism may be used for the machine in video:

<https://www.youtube.com/watch?v=SUgF24GcDi0>

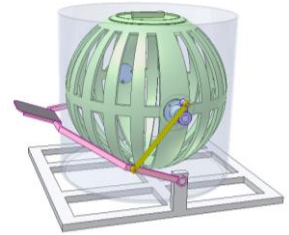

Foot powered washing machine 2

<https://youtu.be/RbKdInIEOcs>

A spatial 4-bar linkage (pink rockers, violet cranks and green conrods) is used for converting oscillation into continuous rotation.

Washing tub is fixed to the base. Washing cage is fixed to the violet crank.

For easy start do not stop the machine at dead positions of the 4-bar linkage (where the violet crank and the green conrod are in line).

This mechanism may be used for the machine in video:

<https://www.youtube.com/watch?v=UMyhP0aeVLw>

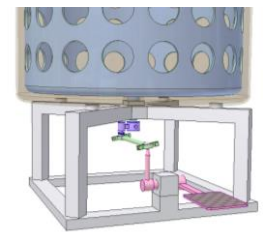

Foot powered rotary table

<https://youtu.be/TjiC9M44rR4>

A spatial linkage is used for converting oscillation of pink pedal into continuous rotation of orange table.

The conrod consists of two parts (green and blue) that are connected together by a revolute joint. The conrod is connected with the pink and violet cranks by Cardano joints (yellow crosses).

It's possible to use spherical joints instead of Cardano joints. See:

<https://youtu.be/RbKdInIEOcs>

If the table can't start because the mechanism has been stopped at dead positions (where the violet crank and the conrod are in line), turn the table a little by hand to overcome them.

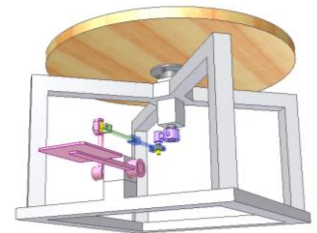

Pottery wheel 2

<https://youtu.be/FVY2pe3Pv2I>

Press pink pedal to make orange wheel rotate via a bevel gear drive and an overrunning clutch. Continuous rotation is possible thanks to the wheel inertia. The pink counterweight tends to bring the pedal to its upper position (it can be replaced with a spring).

For the overrunning clutch see:

http://youtu.be/bAL_nWjuhOI



Angular reciprocation to one way rotation 2

<https://youtu.be/gWUKiZ4SRwU>

Sitting operator feet give green pedals angular reciprocating motion.

The pedals turn in opposite directions thanks to Hobson mechanisms of red angular bar.

Spherical 4-bar linkage converts reciprocating motion of violet shaft into one way rotation of orange output vertical shaft.

The inertia helps the linkage overcoming dead positions.

Turn the output shaft a little if the linkage starts at its dead positions.

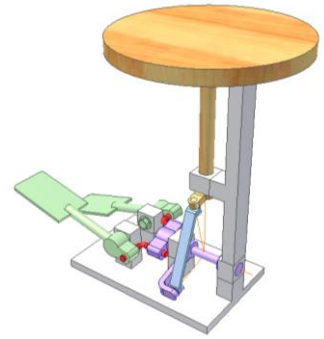

Angular reciprocation to one way rotation 3

<https://youtu.be/xEqCmf4ZPQM>

Sitting operator feet give green pedals angular reciprocating motion.

The pedals turn in opposite directions thanks to three bevel gears.

Spherical 4-bar linkage converts reciprocating motion of violet gear into one way rotation of orange output vertical shaft.

The inertia helps the linkage overcoming dead positions.

Turn the output shaft a little if the linkage starts at its dead positions.

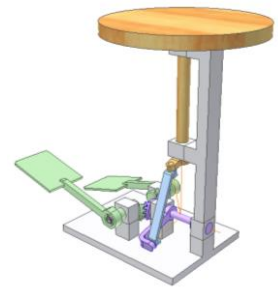

Angular reciprocation to one way rotation 4

<https://youtu.be/lddJcBg6wnA>

Input: violet pedal performing angular reciprocation.

Operator foot presses the pedal down, green spring pushes it up.

Spherical 4-bar linkage converts reciprocating motion of violet shaft into one way rotation of orange output vertical shaft.

The inertia helps the linkage overcoming dead positions.

Turn the output shaft a little if the linkage starts at its dead positions.

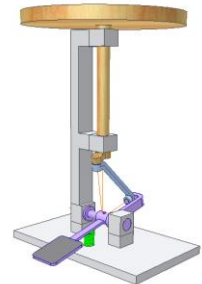

Foot-powered vertical grinder

<https://youtu.be/Pv1dOxkLphw>

Pink slider moves up-down in a slot of the grinder post thanks to a slider-crank mechanism (blue rocker, green conrod). Foot force applied to the green conrod makes the pink slider move down.

Violet spring makes the pink slider move up.

Red pin fixed to yellow slider turns grey shaft only when the pink slider moves down. The red pin slide on the grey shaft when it moves up.

Profile of helical grooves of the grey shaft is not symmetrical (see the video last scene). The inertia helps the grinding wheel rotate continuously.

There are other ways to convert reciprocating motion of the pink slider into rotary motion:

<http://youtu.be/mNcr5Yv3pG8>

<https://youtu.be/8MdA1leM6Y0>

This video was made in an attempt to explain the transmission of the grinder shown at:

<https://youtu.be/ErMs--ZJAqo>

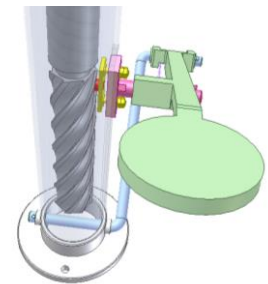

Angular reciprocation to one way rotation 1

https://youtu.be/Gp0_GXf993g

Input: pink cranks (their pedals are not shown) performing angular reciprocation.

Two red pawls make violet ratchet wheel of output chain wheel rotate in one direction. The pawls are forced towards the ratchet wheel by springs (not seen).

The cranks turn in opposite directions thanks to three bevel gears.

Blue pin on orange gear limits reciprocating angle of the cranks.

This mechanism can be used for bicycle transmission as shown in

<https://youtu.be/h5-Ew9LJXV4>

It's said that this way of pedaling gives higher efficiency than full revolution pedaling.



Mechanism for converting interrupted rotation to continuous rotation 1

<http://youtu.be/zjiv5NIT-54>

Input: green ratchet wheel of two spring pins rotating interruptedly.

Output: flywheel of two spring pins.

Flywheel inertia and spring connection between the input and output make the output rotate continuously.

Output motion irregularity depends on flywheel inertia and spring parameters.

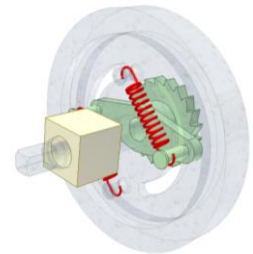

Mechanism for converting two-way to one-way rotation 1a

<http://youtu.be/N49LqVQChMg>

The yellow input shaft may change rotation direction but the rotation direction of the orange output gear keeps unchanged because of ratchet mechanisms placed between the yellow shaft and the big gears. Friction overrunning roller clutch can be used instead of ratchet mechanism to avoid noise and backlash.

The mechanism has the same function if the orange shaft is input and the yellow shaft is output.

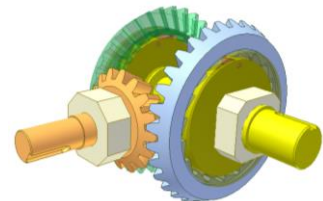

Mechanism for converting two-way to one-way rotation 1b

https://youtu.be/iVQOj_Wqr_8

Input: green shaft

Output: gray shaft

They are coaxial.

The output rotary direction is unchanged regardless of rotary direction of the input.

Bevel gears are connected to the output shaft by ratchet mechanisms of pink pawls (one-way overrunning clutches: https://www.youtube.com/watch?v=bAL_nWjuhOI).

Springs for the pawls are not shown.

Roller overrunning clutches are better option:

<http://youtu.be/H4SiM5Dcblg>

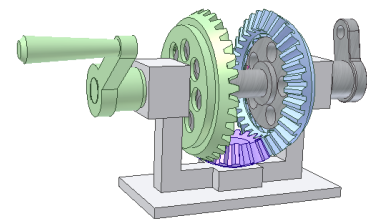

Mechanism for converting two-way to one-way rotation 1c

<https://youtu.be/JOu3ZFo2Vqw>

Input: green shaft

Output: orange shaft

They are coaxial.

The output rotary direction is unchanged regardless of rotary direction of the input.

Bevel gears (in green and blue) are connected to the output shaft by ratchet mechanisms of red pawls which are forced towards the ratchet wheels by blue springs.

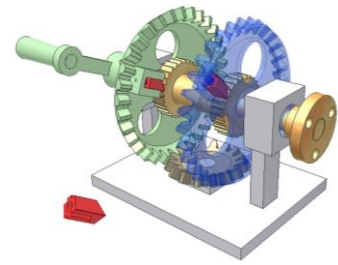

Mechanism for converting two-way to one-way rotation 4

<http://youtu.be/AQRuCse7ENY>

The red input shaft may change rotation direction but the rotation direction of the cyan output gear shaft unchanged due to two spring clutches. One connects the red input shaft and the cyan output shaft. The other connects the yellow gear and the cyan output shaft. The yellow gear rotates free of the output shaft in absence of the orange spring.

The spring helix direction is the key factor for this mechanism.

The springs must be of the same hand direction (here right-hand).

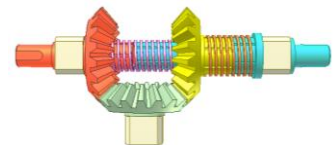

Mechanism for converting two-way to one-way rotation 2

<http://youtu.be/esVq6jfTiqM>

The orange input gear may change rotation direction but the rotation direction of the blue and green gears keeps unchanged.

The yellow idle gear moves in the curved slot because of gear forces.

There is a slight lag during the input gear's reverse.

The mechanism should be used only for low speed case because of gear collision.

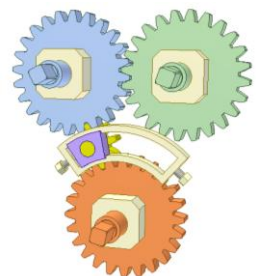

Mechanism for converting two-way to one-way rotation 3

<http://youtu.be/qeotBGLVn7A>

The blue input disk may change rotation direction but the rotation direction of the orange output ratchet wheel keeps unchanged.

The yellow adjustable eccentric cam is fixed on the disk and rocks the green U-shaped follower carrying the pink pawl.

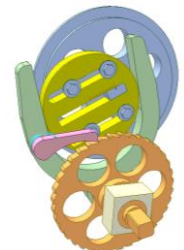

Mechanism for converting two-way to one-way rotation 5

<http://youtu.be/x2JieVQlek0>

The blue input gear may change rotation direction but the rotation direction of the green output shaft keeps unchanged. The yellow gear rotates idly on the blue shaft. The orange rings represent thrust bearings.

The pink shaft moves longitudinally when the input reverses because of axial component of gear forces.

There is a slight lag during the input shaft's reverse.

The mechanism should be used only for low speed case because of gear collision.

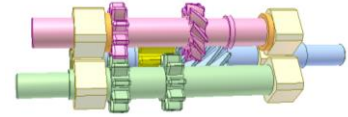

Face gear 13

<http://youtu.be/h6upHEisp74>

Mechanism for converting two-way to one-way rotation.

The blue input shaft may change rotation direction but the rotation direction of the yellow output gear keeps unchanged.

The pink shaft moves longitudinally when the input reverses because of axial component of gear force in the blue gear drive.

The mechanism should be used only for low speed case because of gear collision.

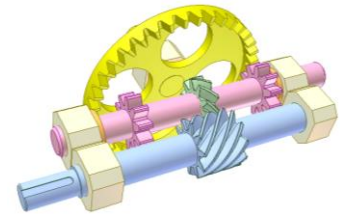

Mechanism for converting two-way to one-way rotation 6a

<https://youtu.be/pAopMTU9s7g>

The violet input gear may change rotation direction but the rotation direction of the orange output shaft keeps unchanged.

All gears are of the same tooth number.

Violet and blue gears are in mesh with yellow one.

Violet gear is in mesh with green one.

Pink and white springs are of opposite hand directions.

One spring end is fixed to gear.

The video shows two side views of mechanism alternately.

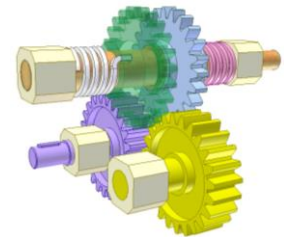

Mechanism for converting two-way to one-way rotation 6b

<https://youtu.be/etlnSt0XqRE>

It is "Mechanism for converting two-way to one-way rotation 6a" with an added internal gear in order that input and output shafts are in line.

The grey input gear may change rotation direction but the rotation direction of the orange output shaft keeps unchanged.

All external gears are of the same tooth number.

Violet and blue gears are in mesh with yellow one.

Violet gear is in mesh with green one.

Grey internal gear is in mesh with yellow one.

Pink and red springs are of opposite hand directions.

One spring end is fixed to gear.

The transmission tracks:

When the grey input shaft rotates clockwise:

grey gear – yellow gear – blue gear – orange output shaft.

When the grey input shaft rotates anticlockwise:

grey gear – yellow gear – violet gear – green gear - orange output shaft.

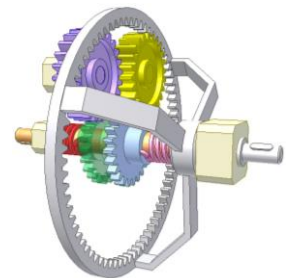

9.2. Converting reciprocating linear motion into continuous rotation

Converting two way linear motion into one way rotation 1

<http://youtu.be/0dJC8lqa8K0>

The green and yellow gears idly rotate on the output violet shaft of ratchet wheels. Each gear has its pawl engaging with the ratchet wheel. Input grey frame carrying two racks has go and back linear motion. The green rack engages with the green gear. The yellow rack engages with the yellow gear. The red leaf springs force the pawls toward the ratchet wheel.

The ratchet wheel always rotate anti-clockwise regardless of go or back motion of the frame.

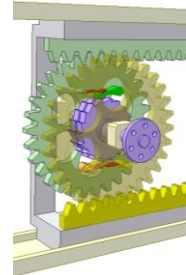

Ratchet mechanism 11b

<http://youtu.be/Yb4wuEACcTk>

Converting linear reciprocating motion into continuous rotation.

Input: pink slider.

Output: orange ratchet wheel.

Springs for forcing the pawls towards the ratchet wheel are not shown. Both go and back motions of the pink slider are useful. Violet pawl pushes and green pawl pulls the wheel.

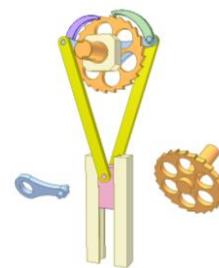

Barrel cam mechanism BT5

<http://youtu.be/mNcr5Yv3pG8>

Linear reciprocating motion is converted into continuous rotation. Key factor is the inconstant depth of the slots.

Stroke length of the yellow slider must be equal to axial length of the cam profile.

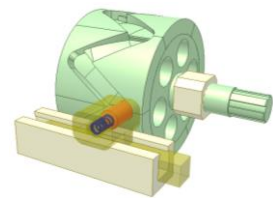

Converting two way linear motion into one way rotation 2

<http://youtu.be/LjvhazEt0UA>

Two bicycle freewheels are fixed in the same direction on orange output shaft.

Their green sprockets are connected to blue sliding plate via pink levers and yellow conrods. When the blue plate goes up down the output shaft turns in one direction.

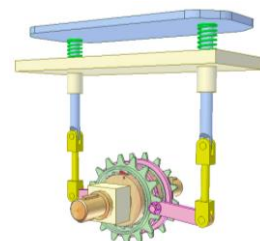

Converting two way linear motion into one way rotation 3

<http://youtu.be/MswriP9QKxE>

Input: blue screw having two threaded portions of opposite hands.

Output: glass gear having two ratchet wheels.

Two red bushes create revolution joint with the output gear and helical joints with the screw.

Reciprocate linear motion of the screw makes the two bushes oscillate in opposite directions. Ratchet mechanisms (two blue pawls) convert motions of the two bushes into one way rotation of the output gear.

Using ball screw drives and roller overrunning clutches instead of lead screw drives and ratchet mechanisms gives better output motion.

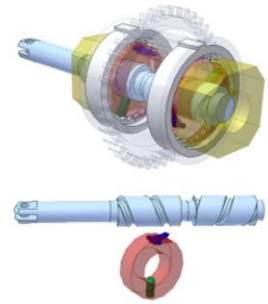

Converting two way linear motion into one way rotation 4

<https://youtu.be/8MdA1leM6Y0>

Input: yellow slider linearly reciprocating with constant stroke length.

Output: blue shaft rotating continuously.

Upper figure shows developed groove of the blue shaft.

Key factor: upper and lower profiles of the groove are different to ensure the output one-way rotation.

This mechanism can also convert rotary motion into linear reciprocating one.

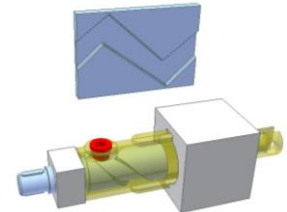

Converting two-way linear motion into one way rotation 7

https://youtu.be/SPQk_ymBOTs

Input: blue slider (a linear cam) reciprocating.

Output: grey shaft rotating continuously.

To ease the output rotation the cam slanting angle must not large (20 deg. in this video).

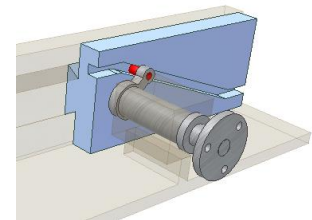

Space ratchet mechanism 1

<https://youtu.be/eYLyDkHndul>

Input: green shaft linearly reciprocating.

Output: grey nut rotating interruptedly. It plays role of a ratchet wheel.

Spring pin (in pink) plays role of a pawl.

Pay attention to asymmetric profile of the nut thread.

The engagement between the pawl and the nut threads happens only when the shaft moves down.

When the shaft moves up, the pin slides on the nut threads.

If the nut inertia is large enough, it can rotate continuously.

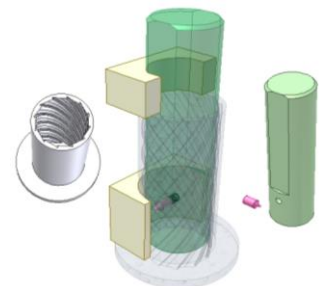

Converting two way linear motion into one way rotation 5

<https://youtu.be/gOXnr1CT0nY>

Input: green double shaft linearly reciprocating.

Output: grey shaft rotating continuously.

It is an application of the mechanism shown at:

<https://youtu.be/eYLyDkHndul>

Grey gear is fixed to grey nut.

Yellow gear is fixed to yellow nut.

Both up and down displacements of the green shaft do work.

The grey and yellow nut are of the same handedness (right-handed in this video) but the thread profiles are opposite.

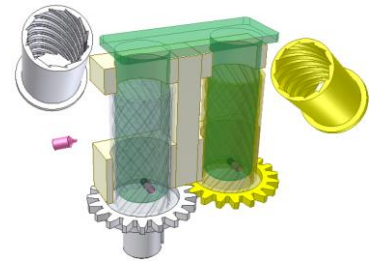

Space ratchet mechanism 2

<https://youtu.be/HLDWn6vBUck>

Input: yellow tube linearly reciprocating.

Output: blue screw rotating intermittently. It plays role of a ratchet wheel.

Flat spring of red pin plays role of a pawl.

Pay attention to asymmetric profile of the screw thread.

The engagement between the pawl and the screw threads happens only when the tube moves down.

When the tube moves up, the pin slides on the screw threads.

If the screw inertia is large enough, it can rotate continuously.

The mechanism can be used for spin mops.

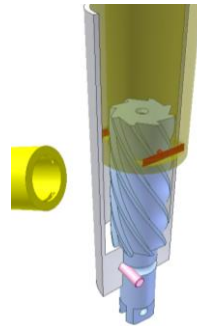

Converting two way linear motion into one way rotation 6

<https://youtu.be/4ziGR9ggO60>

Input: yellow button linearly reciprocating.

Output: blue screw shaft rotating one way.

It is an application of the mechanism shown at:

<https://youtu.be/HLDWn6vBUck>

Both up and down displacements of the yellow button do work.

The screw has two threaded portions of opposite hands.

If the screw inertia is large enough (with an attached flywheel), it rotates continuously.

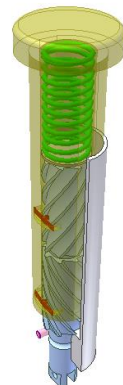

Floating rack 1

<https://youtu.be/ReeqL7g6Ctc>

This mechanism converts linear reciprocating motion of green slider into intermittent rotation of yellow gear.

Blue rack, orange rockers create a parallelogram mechanism.

Red leaf spring always forces the rack toward the gear.

Pay attention to the positions of red stoppers at the ends of the green slider.

Load on the gear keeps it immobile when the slider moves to the left.

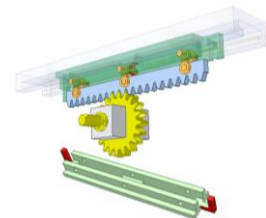

Floating rack 2

<https://youtu.be/k6RqU0F6QdA>

This mechanism converts linear reciprocating motion of green slider into one way rotation of yellow gear.

Blue rack, orange rockers create a parallelogram mechanism.

Red leaf springs always force the racks toward the gear.

It is developed from mechanism "Floating rack 1" shown at:

<https://youtu.be/ReeqL7g6Ctc>

Another similar mechanism of the same function:

<http://youtu.be/0dJC8lqa8K0>

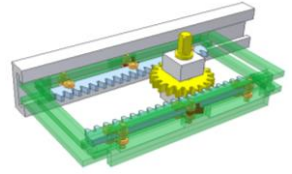

10. Mechanisms for creating complicated motions

10.1. Planar motions

Gear and linkage mechanism 8b

<http://youtu.be/wTG1Ai2S9I8>

The gears have the same tooth number and the same distance of their pins to their rotation axes.

The green bar has complicated motion in general.

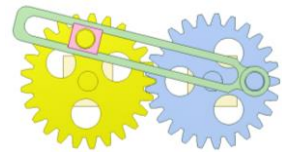

Slider-crank mechanism with gears on conrod

<https://youtu.be/doSUZ1AdKU8>

The orange gear and orange crank are fixed together.

The blue and pink gears, each rotates idly on its axle.

The orange and pink gear have the same tooth number.

The input crank rotates regularly while the blue and pink gears rotate irregularly.

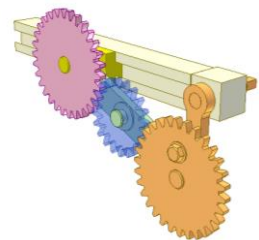

Fixed cam mechanism 2

<http://youtu.be/LFpE2USzXsU>

The green input crank rotates. The orange cam is fixed. This example aims to prove that the cam does not always an input rotational link and the follower has planar motion.

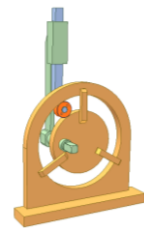

Fixed cam mechanism 3

<http://youtu.be/MEfBhY9RI08>

A device of machines for unearthing potato.

Input is the green disk. The orange grooved cam is fixed. The blue follower, at one end of which is fixed a hoe, has planar motion.

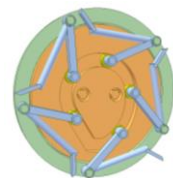

Mechanism of cam's planar motion 1

<http://youtu.be/qGHpenVs6wg>

Input is the pink eccentric shaft. The orange cam has planar motion.

Output is the blue crank. Adjust position of the violet lever to get various motions of the output crank. Gravity maintains permanent contact between rollers and cam.

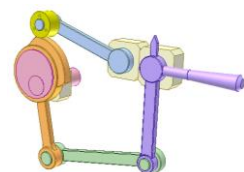

Mechanism of cam's planar motion 2

<http://youtu.be/Gr-2Hbun0TA>

Input is the pink crank. The orange cam has planar motion.

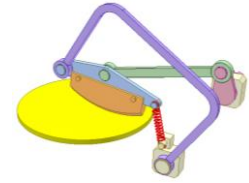

Cam mechanism of follower's planar motion 1

<http://youtu.be/NXA99a7HjXg>

The green follower, connecting rod of a parallelogram mechanism, has planar motion. Gravity maintains permanent contact between roller and cam.

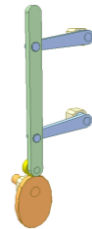

Turn and stretch mechanism 2

<https://youtu.be/scXGX4iGp-g>

Yellow base and yellow gear are stationary.

Blue frame to which blue rack is fixed has prismatic joint with the glass frame.

Green frame to which green rack is fixed has prismatic joint with the glass frame.

When turning the frame to which grey rack is fixed, the blue and green frames stretch out.

The green moves twice faster than the blue thanks to red gear that has revolution joint with the blue frame.

Stroke length S of the blue frame:

$$S = 2 * (\alpha / 360) * (m * Z_y * \text{Pi})$$

α : rotary angle of the glass frame (deg)

m: module of the yellow gear

Z_y : tooth number of the yellow gear

$\text{Pi} = 3.142$

To increase stroke length of the green frame it is possible use other mechanisms: lazy tongue, cable, ...

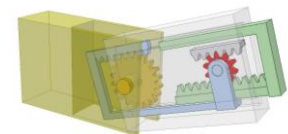

Fixed cam of parallelogram groove

<http://youtu.be/Rx32dbLwf2c>

Input: pink slider reciprocating with constant stroke length.

Output: green rocker of complicated motion.

Green pin of the rocker moves clockwise along the groove on yellow fixed cam.

Violet flat spring does not allow the pin go counter-clockwise at the cam upper corner.

The gravity does not allow the pin go counter-clockwise at the cam lower corner.

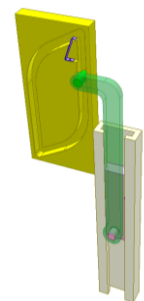

Cable drive 24

<http://youtu.be/nT0DdQAaf-k>

The pink crank and the pink pulley are fixed together. They are driving link of reciprocating rotation.

The red weight has a complicated motion.

It goes up and down under influence of the 4-bar mechanism and the cable drive of two pulleys.

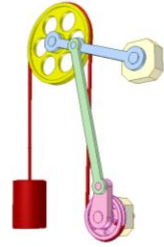

Cable drive 26

<http://youtu.be/7b0V0cHyQas>

Converting continuous rotation of the pink gear crank to reciprocating translation of the red slider.

The red slider and the pink slider are fixed to the cable.

The blue wheels and the green pulleys rotate idly on axles of the yellow bar.

The red slider receives two motions:

- From the orange crank slider mechanism.
- From the pink crank slider mechanism and cable drive.

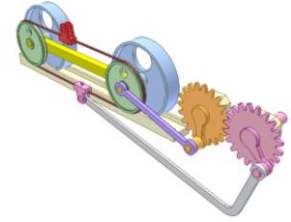

Chain drive 6A

<http://www.youtube.com/watch?v=94rvs8aUWs8>

Satellite chain drive.

The blue bar plays role of a carrier. The orange and yellow sprockets have the same tooth number. Input is the orange sprocket that has reciprocating rotation. Full rotation is impossible. The violet bar has a revolution joint with a chain link. The carrier and the violet bar oscillate.

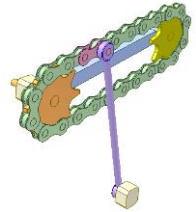

Chain drive 6B

<http://www.youtube.com/watch?v=09Qz6ErIOEQ>

Satellite chain drive.

The blue bar plays role of a carrier. The orange and yellow sprockets have the same tooth number. The violet bar has a revolution joint with a chain link.

Input is the blue bar that has reciprocating rotation. More than 1 revolution is impossible.

The sprockets and the violet bar oscillate.

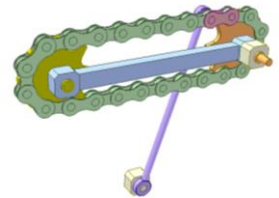

Chain drive 7A

<http://youtu.be/s-H37-c1CP0>

Chain drive of two movable sprockets.

The yellow sprockets have the same tooth number.

The driving pink lever, having a revolution joint with the violet chain link, oscillates around a fixed pivot.

The orange link oscillates in a fixed house.

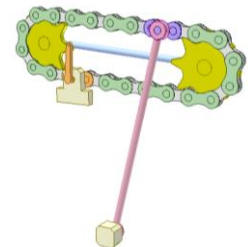

Chain drive 7B

<http://youtu.be/OxLFWIWh5As>

Chain drive of two movable sprockets.

The yellow sprockets have the same tooth number.

The driving pink lever, having a revolution joint with the blue carrier, oscillates around a fixed pivot.

The orange link oscillates in a fixed house.

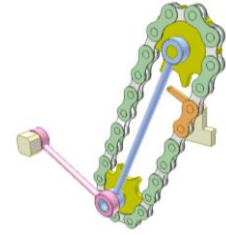

Chain drive 11A

<http://youtu.be/ClxbhMnXTfI>

There are two chain drives. One is of satellite type.

They are connected together by two pink chain links and an yellow bush.

Input is the orange sprocket.

The video shows how complicatedly the satellite chain drive moves.

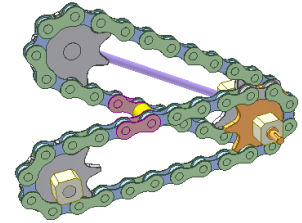

Chain drive 11B

<http://youtu.be/Cv8h7LGBDm0>

There are two chain drives. They are of satellite type.

The chains are connected together by two pink chain links and a red bush.

The blue and yellow sprockets are coaxial but rotate independently.

The porcorn sprocket is fixed.

Input is the orange carrier.

The video shows complicate motions of two drives.

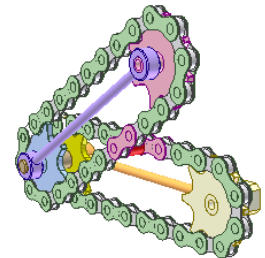

Zigzag translation 1

<https://youtu.be/ANI8m9Z7Qy0>

Yellow slider translates along a zigzag line.

Blue slider of an ordinary slider-crank mechanism carries the yellow slider that can move in direction perpendicular to the motion direction of the blue slider. Violet pink fixed to the yellow slider moves along the zigzag slot of white stationary runway.

The zigzag line can be changed to any shape.

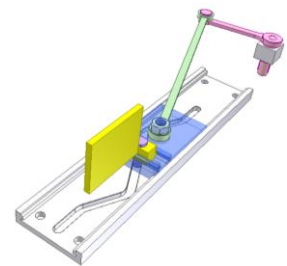

Zigzag translation 2

<https://youtu.be/GUpmxBlezNg>

Blue slider translates along a zigzag line.

Center distance of two red pins is equal to the zigzag slot pitch.

It is simpler in comparison with "Zigzag translation 1":

<https://youtu.be/ANI8m9Z7Qy0>

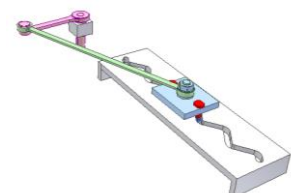

Oscillating linear motion

<https://youtu.be/4Ww1ILWEVFc>

Blue plate oscillates and goes straight at the same time.
Center distance of two red pins is equal to half of the zigzag slot pitch.

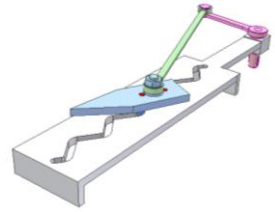

Snake style motion

https://youtu.be/IFSMuNOth_4

Center distance of two adjacent red pins is equal to half of the zigzag slot pitch.



10.2. Spatial motions

Nut-screw and bar mechanisms 2a'

<http://youtu.be/W10lxIOMVpo>

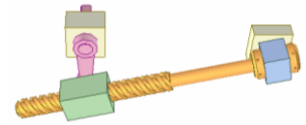

Spatial slider crank mechanism 6

<http://www.youtube.com/watch?v=3h9C7mjcwoU>

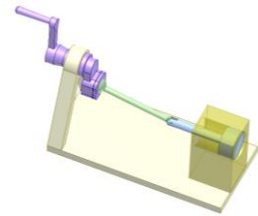

Twisted slider

http://www.youtube.com/watch?v=2_ioqY-O4Jo

Standard four-bar linkage has a screw substituted for a slider. The output is helical rather than linear.

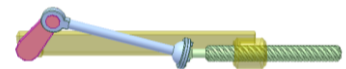

Screw-slider-crank mechanism

<http://youtu.be/OTdcOR3Byws>

The helical joint between the green screw slider and the orange bush makes the latter have reciprocating rotation. Screw lead angle must be big enough to avoid jerk.

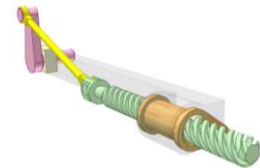

Barrel cam mechanism BT8

<http://youtu.be/hs07gwcfbwM>

The pink cam is fixed. The green crank rotates. The yellow follower slides in a rectangular hole of the crank.

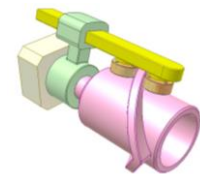

Double cam mechanism 3

<http://youtu.be/5UUPAd39ZG0>

Four motion feed used on sewing machines for moving the cloth. A combination of disk cam and face cam.

The grey fork carrying green bar translates thanks to blue face cam and pink pin. Yellow spring maintains their contact.

The green bar oscillates around a pivot on the fork thanks to blue disk cam and orange roller. Gravity maintains their contact.

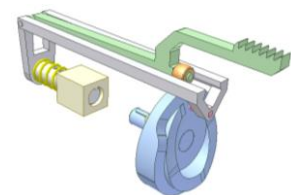

Double cam mechanism 1

<http://youtu.be/hVaozVJ9C7w>

A combination of disk cam and barrel cam.

The disk cam moves green follower.

The barrel cam moves yellow follower.

A point of the yellow follower traces the orange rectangle that is used for moving film in cameras.

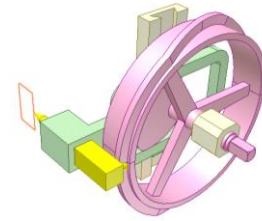

Double cam mechanism 2

<http://youtu.be/rZctm5qDcwU>

Input: green cam, a combination of disk cam and barrel cam.

Output: brown crank that oscillates and linearly reciprocates.

The gravity maintains contact between the cam and orange roller.

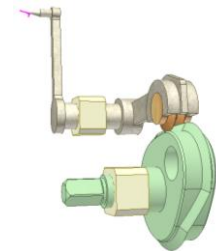

Barrel cam mechanism BR2

<http://youtu.be/jfHfx-gCERs>

The yellow cam is a combination of an eccentric cam and a barrel one.

Contacting both cylinder surface (by two planes) and groove (by a red pin) of the yellow cam, the green follower has complicated motion.

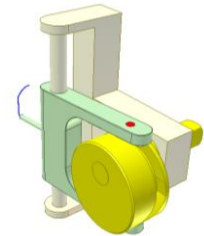

Spatial crank slider mechanism 7

<https://www.youtube.com/watch?v=jDg71wX2gmc>

Input: orange crank rotating continuously.

Output: pink shaft oscillating and linearly reciprocating.

The green sleeve has two skew perpendicular holes.

Relative position between input axis and output axis is arbitrary, even skew.

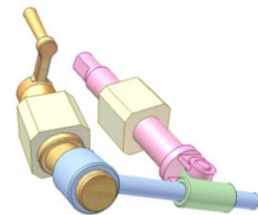

Needle capture mechanism

<https://youtu.be/T7xrCIRyWnY>

Input: pink shaft carrying a gear and a face cam.

Thanks to the cam, when grey cylinder turns 1 revolution, yellow arm moves out and in several times. The number of its motion depends on transmission ration of a train of four gears.

This mechanism is used for capturing needles in knitting machines.

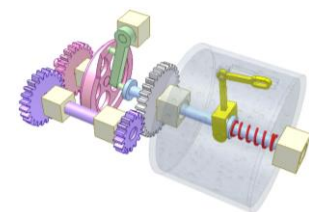

Turn and stretch mechanism 1

<https://youtu.be/G4NQdUsnSu8>

Input: green helical gear.

Output: yellow rack slider having rotary and linear motions at the same time.

Blue helical gear is fixed to the blue carrier. The latter has small satellite spur gear (in pink) which is in mesh with grey stationary face gear. Large spur gear (fixed to the shaft of the small satellite gear) is in mesh with the yellow rack.

The mechanism can be self-locking if transmission ratio of the helical gear drive is large enough.

This video was made on request of a YouTube viewer.

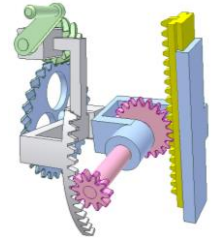

Mechanism for moving works in oven

<https://youtu.be/m6u2C2ioLiY>

Input: pink cylinder.

Blue crank, brown conrod and grey trolley create a slider crank mechanism. Yellow work has complicated motion that can be varied by changing dimensions of the blue bar.

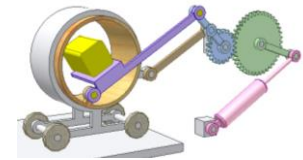

Helix torus cam

<http://youtu.be/tlhtEbzVj5g>

The green input part rotates. The yellow bush carrying a pin rotates around its own axis. The pink slider moves along a fixed runway.

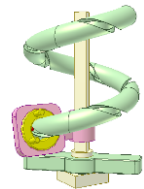

Turn and stretch mechanism 3

<https://youtu.be/ZKczlmttHnw>

Yellow base and yellow gear are stationary.

Green slider has prismatic joint with glass carrier of orange satellite gear.

The green slider has helical joint with the orange gear via red pin fixed to the orange gear.

When the carrier rotates, the slider moves in and out. Its stroke length S can be large, subject to the lead L of helical slots.

$$S = (\alpha/360) \cdot (Z_y/Z_o) \cdot L$$

α : rotary angle of the carrier (deg)

Z_y and Z_o : tooth numbers of yellow and orange gears.

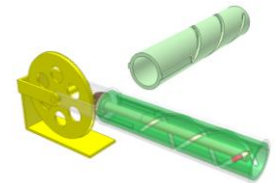

Helical motion 1

<https://youtu.be/Qfnf0tKeQzk>

Input: blue gear sector (angular reciprocating motion).

Output: grey shaft of helical groove performing the helical motion.

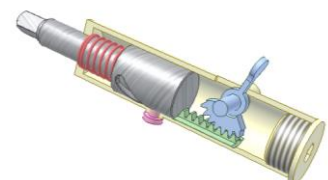

Rotation and translation shaft 1

https://youtu.be/ddh_PNoIXWl

Input: block of gear and pulley (in pink) that can change its rotary direction.

Output: blue shaft that rotates and translates. For each revolution it translates S mm.

$$S = (1 - (Z1*Z3)/(Z2*Z4))*L$$

Z1, Z2, Z3, Z4 are tooth numbers of pink, large green, small green and violet gears respectively.

L: lead of helical joint (blue screw and violet nut) in mm.

In this video Z1 = Z3 = 25; Z2 = Z4 = 50; S = 0.75L

The blue shaft has prismatic joint with the pink block (orange keys).

Alter the tooth numbers for desired S.

The mechanism can be applied for thread cutting.

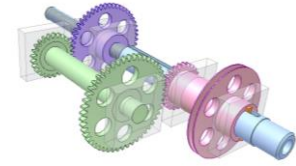

Rotation and translation shaft 2

<https://youtu.be/bG9tciD9RPY>

Turn yellow lever counterclockwise: blue shaft rotates clockwise and move down at rate of Sd mm/rev.

Turn yellow lever clockwise: blue shaft rotates counterclockwise and move up at rate of Su mm/rev.

Block of gear and pulley (in pink) receives rotation from a motor via a belt (not shown). The yellow lever controls the motor (start, stop and rotary direction) by limit switches (not shown).

The blue shaft has prismatic joint with the pink block (cyan keys).

Orange cone clutch has prismatic joint with red nut.

- When the orange clutch engages with violet gear block (rotating idly on the blue shaft), it makes the red nut and the violet block rotate together, the shaft moves down.

$$Sd = (1 - (Z1*Z3)/(Z2*Z4))*L$$

Z1, Z2, Z3, Z4 are tooth numbers of pink, large green, small green and violet gears respectively.

L: lead of helical joint (blue screw and violet nut) in mm.

In this video Z1 = Z3 = 25; Z2 = Z4 = 35; Sd = 0.5L

Alter the tooth numbers for desired Sd.

- When the orange clutch engages with fixed grey cone, the red nut is immobile, the blue shaft moves up. Su = L, faster than Sd.

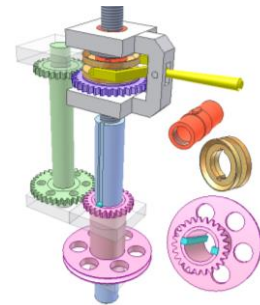

Up-down motion and reverse 180 deg. rotation 1

https://youtu.be/Kp6lwV_ks70

Input: pink crank shaft.

Output: brown T-bar moving up-down and turning 180 deg. in two direction at it upper position.

It is a combination of two mechanisms shown at:

<https://youtu.be/-PhB19njbCc>

and

<http://youtu.be/VPZO7txZIZU>

Transmission ratio of the timing belt drive: 2

It can be used for pick and place devices such as the one shown at:

<https://youtu.be/QfGOnluLyc>

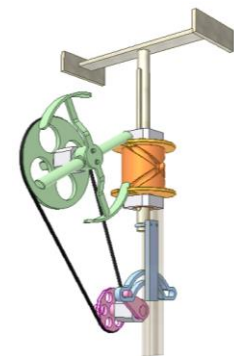

Up-down motion and reverse 180 deg. rotation 2

<https://youtu.be/k7TvmHlrTAW>

Input: green cam crank shaft.

Output: brown T-bar moving up-down and turning 180 deg. in two direction at it upper position.

It is a development of mechanism shown at:

<https://youtu.be/-PhB19njbCc>

It can be used for pick and place devices such as the one shown at:

<https://youtu.be/QfGOnluLyc>

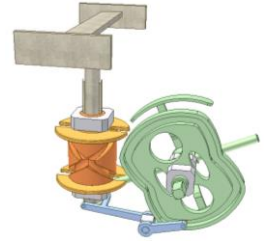

Translation and stretch 1

<https://youtu.be/fFmo-XX7QG6>

Push up yellow desk. It translates vertically, turns 90 deg. and translates further.

The green stopper prevents the desk from falling under gravity when no driving force applied to it.

Pull the green stopper back to let the desk move down. Red roller controls angular position of the desk.

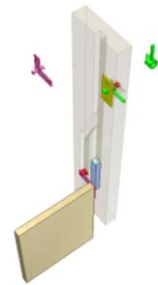

Translation and twist 1

https://youtu.be/MWn_BlzevYM

When pulling the pink spring pin, yellow desk moves forwards, turns 90 deg. and stops at open position under the actions of red spring, green pin and the slot on the blue base.

Push the desk backwards to get closed position when the pink spring pin enters the slot on the blue base.

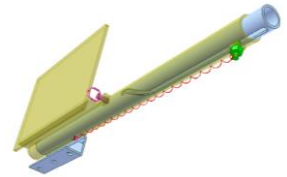

Space pin gear drive 2

<http://youtu.be/O5C8pUquixM>

The pin centers are in a tilted plane, on an ellipse. The orange pin wheel rotates and reciprocates simultaneously. The up motion is caused by meshing force. The down motion is due to the gravity or spring force.



Space pin gear drive 3

<http://youtu.be/RNPO03NbWZA>

The yellow pin rotor oscillates and reciprocates simultaneously.

The pin centers are on a helix curve. One end of the pinion shaft moves along the closed slot on the rotor.

This mechanism is taken from the video of a washing machine:

<http://www.youtube.com/watch?v=-Eu2ca6MSUA>

that an YouTube user (Mr. SolaPazEnergy) has introduced to me.

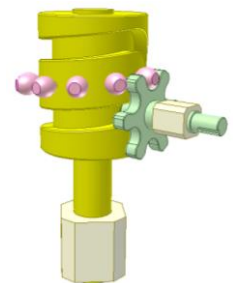

Spatial slider crank mechanism 7

<https://youtu.be/aF3NcdRmay0>

It has only two links.

Inputs: blue crank.

Output: orange slider reciprocating angularly and linearly at the same time.

Joint between the crank and the slider is sphere-in-cylinder one.

Green line is the trajectory of the orange sphere center. It is line of intersection of two cylinders.

The mechanism has dead points when the crank is at its vertical positions.

Application: washing machine agitators.

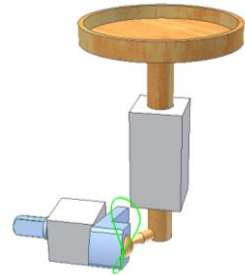

Spatial slider-crank mechanism

<https://youtu.be/LQ-o3fPqO1U>

This video is based on the design numbered as 1589 in volume 2, Mechanisms in modern technic, I. Artobolevski, with some amendments.

Pink crank has cylindrical joint with the base, prismatic joint with yellow driving pulley and spherical joint with the output slider (in glass). The latter has cylindrical joint with the base and performs rotary reciprocating motion while moving up-down.

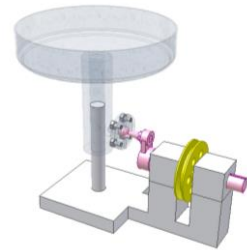

Rotation and translation in turn 1

<https://youtu.be/yuRJFJ2DDd0>

Input: block of yellow barrel cam and green disk cam.

Output: pink shaft: move forward – turn right – move backward – turn left.

The barrel cam controls linear motion.

The disk cam controls 90 deg. angular motion.

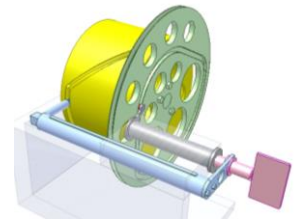

Rotation and translation in turn 2

<https://youtu.be/70OoWgbrXSA>

Blue input crank makes pink pin (fixed to orange tube) move along rectangular runway of the base.

Hence the tube motion is as follows: move forward – turn right – move backward – turn left.

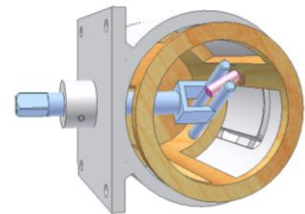

11. Study of mechanisms

11.1. Mechanical joints

Ball bearing simulation 1

<http://www.youtube.com/watch?v=hxUXX0tYMHM>

Outer race stationary

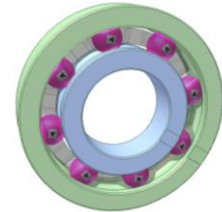

Ball bearing simulation 2

<http://www.youtube.com/watch?v=hxUXX0tYMHM>

Inner race stationary

Axial stopper for a grip

<https://youtu.be/49XXMZdadC0>

The video shows:

A. The assembling process for red spring snap ring.

B. How the glass grip works.

In A: the grip pushes the ring to place it in the circular groove of the blue shaft. The ring is expanded during being pushed. It is compressed when the grip moves further to set the ring in the circular groove of the grip.

In B: when the operator rotates the wheel, the grip translates circularly. The ring prevents the grip from being removed by a small force.

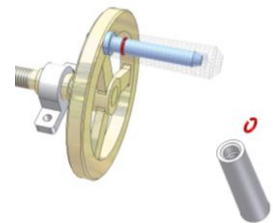

Stamp joint

<http://youtu.be/Wk-JYJHr6u0>

Insert and turn the brass stamp for fixing it to green handle.

Helical groove on the handle and a pin on the stamp are key factors.

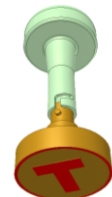

Wedge mechanism 17

http://youtu.be/_I3PPtIjC8

The gap between the green slider and the runway is adjusted by moving the orange wedge. The slopes on the wedge and on the runway are equal.

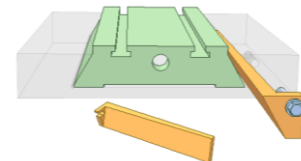

Wedge mechanism 28

<http://youtu.be/rM8FcOcZ9M8>

The gap between the green slider and the runway is adjusted by moving the orange and pink wedges. The slopes on the wedges are equal.

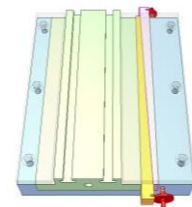

Reducing friction for rollers in runway

<https://youtu.be/2s6yGFs6dyg>

Outer ring of upper ball bearing contacts the runway only with violet surfaces.

Outer ring of lower ball bearing contacts the runway only with yellow surfaces.

So the outer rings can roll with less friction.

Compare with the worse case when bearing outer rings contact the runway at both sides.

Last scene of the video shows the roller motion in oval-shaped runway.

Disadvantage: direction of any object fixed to the roller axle changes uncontrollably.

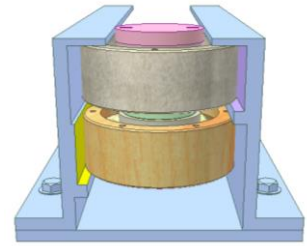

Sphere joint having unsplit outer part 1

<http://youtu.be/gWzPxNvG0Dw>

Length of rectangular slot on the yellow outer part must be larger than the diameter of green sphere.

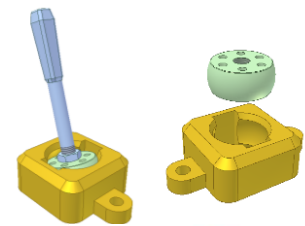

Sphere joint having unsplit outer part 2

<http://youtu.be/KfGUpfkucNM>

The ball has cylindrical portion diameter of which is slightly smaller than diameter of the socket surface hole. Assembling position: axis of the said cylindrical portion is perpendicular to the upper surface of the socket. The ball can not come out of the socket for other positions.



Sphere joint having unsplit outer part 3

<http://youtu.be/4xuFc30z-xo>

The ball has two slots to form 4 wings that are deformed to reduce ball diameter when pushing the ball into spherical hole of the socket. Cone end of the screw is in mesh with cone hole of the ball to prevent the said deformation after assembling thus the ball can not come out of the socket.

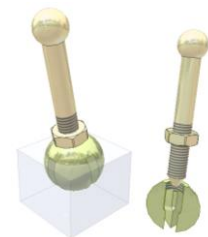

Spherical connection of large turning angle 1

<https://youtu.be/95bZU6yIEzw>

Turning angle of ordinary spherical joints can not exceed 180 deg.

This joint doesn't have such limitation. In fact it is a Hook joint.

Blue sphere has two circular dovetail grooves that are perpendicular to each other. The sphere is divided into two for assembling pink and yellow parts.



Spherical connection of large turning angle 2a

<https://youtu.be/XupyXgd30h8>

Turning angle of ordinary spherical joints can not exceed 180 deg. Mechanism of three revolute joints on the right doesn't have such limitation. In fact it is a Hook joint.



2 DoF spherical connection of large turning angle 1

https://youtu.be/iK253Ww_MwU

Mechanism on the left is a spherical joint with a pin (2 degrees of freedom). Its turning angle can not exceed 180 deg. Mechanism on the right doesn't have such limitation. In fact it is a Hook joint.



Pin spherical joint 1

<https://youtu.be/kztZu3uTyvM>

The sphere has 2 degrees of freedom: rotation around its longitudinal axis and rotation around a horizontal axis.

The pin-groove contact restricts the third rotation of a simple spherical joint.



Pin spherical joint 2

<https://youtu.be/K0dFf9714L8>

The sphere has 2 degrees of freedom: rotation around its longitudinal axis and rotation around a horizontal axis. The sphere is kept by two cone holes on green base and pink cover.

The pin-groove contact restricts the third rotation of a simple spherical joint.

The large circular hole on the pink cover is for inserting the sphere when assembling. The cover is one fourth cut off for easy understanding.



Pin spherical joint 3

<https://youtu.be/MX6HHcQ2dX0>

Orange shaft of spherical end has 2 degrees of freedom: rotation around its longitudinal axis and rotation around vertical axis.

The pin-groove contact restricts the third rotation of a simple spherical joint.

The grey cover is one fourth cut off for easy understanding.

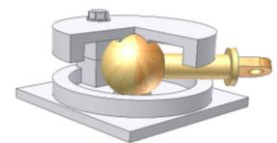

4 DoF joint

<https://youtu.be/2lrOI8ilOw0>

Orange shaft of spherical end has 4 degrees of freedom: 3 rotations and 1 linear translation.

The outer part is one fourth cut off for easy understanding.

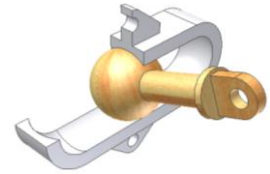

4 DoF connection

<https://youtu.be/vde8SWF5Fmg>

The connection consists of 3 links (2 movable).

Green shaft has 3 DoF spherical joint with pink sphere.

The latter has prismatic joint with the glass base.

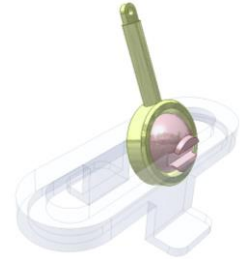

Mechanical torus joint 1

<http://youtu.be/uCEPAw4jxCA>

The joint allows two degrees of freedom (rotations) of relative movement.

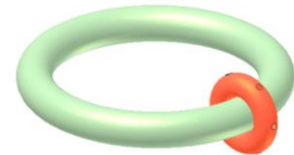

Mechanical torus joint 2

<http://youtu.be/mHkdwnrhsPU>

The joint allows two degrees of freedom (rotations) of relative movement.



Mechanical torus joint 3

<http://youtu.be/BbsGHSC1i5c>

The joint allows two degrees of freedom (rotations) of relative movement.

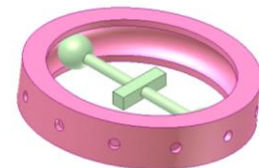

Helix torus joint 1a

<http://youtu.be/3Yw3Hr9WKdg>

There are a helix groove of half rev. ($n = 1/2$) on the big torus. The small torus makes 1 rev. around its axis during 2 rev. around the big torus axis. In other words, the small torus has two interdependent rotary motions.

It is case of Mobius strip (figure on the upper left corner), an ant must crawl two rev. to get the start point.



Helix torus joint 1b

<http://youtu.be/CvsviKzNogq>

There are a helix groove of two rev. ($n = 2$) on the big torus. The small torus makes 2 rev. around its axis during 1 rev. around the big torus axis.

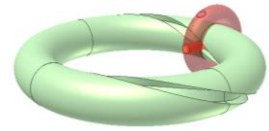

Helix torus joint 1c

<http://youtu.be/6vWSI5JYUoI>

There are a helix groove of one third rev. ($n = 1/3$) on the big torus. The small torus makes 1 rev. around its axis during 3 rev. around the big torus axis.



Mechanical torus joint 4

<https://youtu.be/6yrlo0dxlOw>

The joint allows two degrees of freedom (rotations).

It is not a spherical joint. A point of the yellow part doesn't move on a sphere.

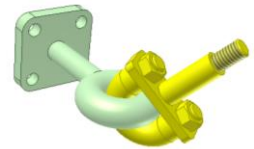

Mechanical torus joint 5

https://youtu.be/_GgPSNcFF2w

The joint between green and orange parts allows two degrees of freedom (rotations).

It can transmit rotary motion between two intersecting shafts.

It is not a constant velocity joint.

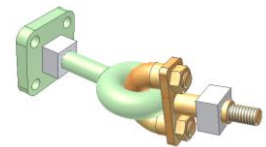

Helix torus joint 2

<http://youtu.be/6s-giKB1TBE>

The orange torus can turn around its own axis. It has also a helical motion around axis of the green spring-shaped part. So this joint has two degrees of freedom.

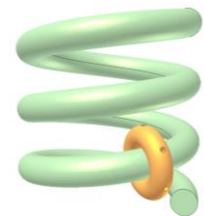

Helix torus joint 3

http://youtu.be/qIGF-C_5FNE

The red torus carrying a pin has two interdependent helical motions around its own axis and around axis of the green spring-shaped part. The pin slides in a helical groove of the green spring-shaped part.

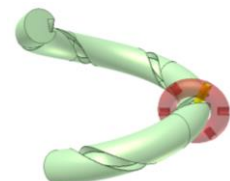

11.2. Planar mechanisms

Equivalency of parallelogram and Oldham mechanisms

<http://youtu.be/wi0NyZNd7I4>

When removing orange slider, it is a parallelogram mechanism.

When removing yellow conrod, it is a Oldham mechanism.

For both cases the motion transmission between two rockers is the same.

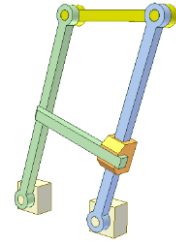

Four bar linkage 8a

<http://youtu.be/ADofvwxYImA>

A special case of the 4-bar linkage.

Input: pink crank

Output: green crank.

The unusualness: a working cycle of the mechanism corresponds 2 revolutions of the input. Output oscillating angle is larger than 180 deg., a thing that is hard to get by using an ordinary 4-bar linkage. It happens because:

1. The sum of the lengths of the two adjacent links is equal to the sum of the lengths of the other two links.

$$A + B = C + D$$

A: length of pink crank (=10)

B: length of yellow conrod (=40)

C: length of green crank (=20)

D: distance between fixed axes of pink and green cranks (=30)

2. There are measures to overcome dead position (when green crank and yellow conrod are in line). For example, inertia of the green crank must be big enough.

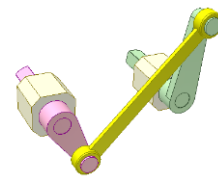

Four bar linkage 8b

<http://youtu.be/Y5IMzmEPOX0>

A special case of the 4-bar linkage.

Input: pink conrod.

Output: oscillating green and yellow cranks.

The unusualness: a working cycle of the mechanism corresponds 2 revolutions of the driving crank (in pink) Output oscillating angles are larger than 180 deg., a thing that is hard to get by using an ordinary 4-bar linkage. It happens because:

1. The sum of the lengths of the two adjacent links is equal to the sum of the lengths of the other two links.

$$A + B = C + D$$

A: length of green crank (=40)

B: length of pink conrod (=10)

C: length of yellow crank (=36)

D: distance between fixed axes of cranks (=14)

2. There are measures to overcome dead positions (when cranks are in line with pink conrod). For example, inertia of the cranks must be big enough.

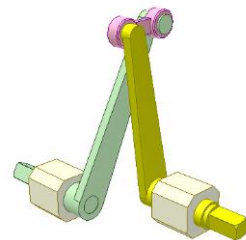

Four bar linkage 8c

<http://youtu.be/BOJSJvOUyAE>

A special case of the 4-bar linkage.

Input: pink crank.

Output: green crank rotating irregularly.

The unusualness: a working cycle of the mechanism corresponds 2 revolutions of the input. It happens because:

1. The sum of the lengths of the two adjacent links is equal to the sum of the lengths of the other two links.

$$A + B = C + D$$

A: length of pink crank (=35)

B: length of yellow conrod (=15)

C: length of green crank (=40)

D: distance between fixed axes of cranks (=10)

2. There are measures to overcome dead positions (when the cranks are in line with yellow conrod). For example, inertia of the cranks must be big enough.

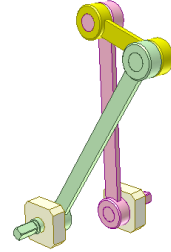

Four bar linkage 9a

http://youtu.be/nP_tGreHHEY

A special case of the 4-bar linkage.

Input: pink crank.

Output: oscillating green crank.

The unusualness: a working cycle of the mechanism corresponds 2 revolutions of the input. Output oscillating angles are larger than 180 deg., a thing that is hard to get by using an ordinary 4-bar linkage. It happens because:

1. The sum of the lengths of the two opposite links is equal to the sum of the lengths of the other two links.

$$A + B = C + D$$

A: length of pink crank (=10)

B: length of green crank (=40)

C: length of yellow conrod (=35)

D: distance between fixed axes of cranks (=15)

2. There are measures to overcome dead positions (when green crank is in line with yellow conrod). For example, inertia of the green crank must be big enough.

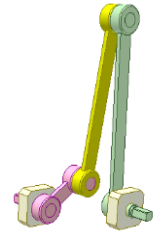

Four bar linkage 9b

<http://youtu.be/Aqg7tl4jfe8>

A special case of the 4-bar linkage.

Input: pink crank.

Output: green crank rotating irregularly.

The unusualness: a working cycle of the mechanism corresponds 2 revolutions of the input. It happens because:

1. The sum of the lengths of the two opposite links is equal to the sum of the lengths of the other two links.

$$A + B = C + D$$

A: length of pink crank (=15)

B: length of green crank (=35)

C: length of yellow conrod (=40)

D: distance between fixed axes of cranks (=10)

2. There are measures to overcome dead positions (when green crank is in line with yellow conrod). For example, inertia of the green crank must be big enough.

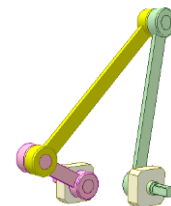

Four bar linkage 9c

<http://youtu.be/4rTbsT7hTcg>

A special case of the 4-bar linkage.

Input: pink conrod.

Output: oscillating cranks.

The unusualness: a working cycle of the mechanism corresponds 2 revolutions of the input. Oscillating angle of the yellow crank is larger than 180 deg., a thing that is hard to get by using an ordinary 4-bar linkage. It happens because:

1. The sum of the lengths of the two opposite links is equal to the sum of the lengths of the other two links. $A + B = C + D$

A: length of pink conrod (=10)

B: length of green crank (=35)

C: length of yellow crank (=15)

D: distance between fixed axes of cranks (=40)

2. There are measures to overcome dead positions (when cranks are in line with pink conrod). For example, inertia of the cranks must be big enough.



Study of parallelogram mechanism 1a

<http://youtu.be/wraqhhhe-h8>

Two mechanisms are identical.

Lengths of three cranks are equal.

Yellow, green and blue links create a parallelogram.

Input: yellow cranks. Output: orange cranks.

Besides the dead positions (when the cranks and the bars are in line)

the mechanisms have unstable positions when the cranks are perpendicular to white and green bars.

When the mechanisms overcome unstable positions output motions may change.

The mechanisms can work stably in the range of less than 90 deg. of the input.

For the left mechanism the input and output turn in opposite directions.

For the right mechanism the input and output turn in the same direction.

This phenomenon depends on initial relative position between input and output cranks.

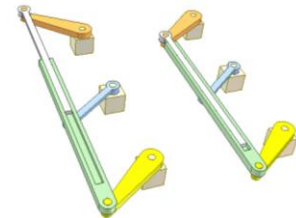

Spring linkage mechanism 1

<http://youtu.be/XVoarCYMIVc>

The behind is a coulisse mechanism. The front one is the same but the prismatic joint is replaced by a pull spring.

Tips of the orange levers trace similar curves.

However different loads applied to the orange lever of the spring mechanism may alter curve shape.

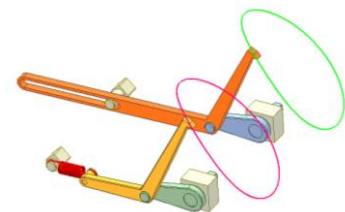

Spring linkage mechanism 2

<http://youtu.be/wVKjmL3iOQo>

The behind is a coulisse mechanism. The front one is the same but the prismatic joint is replaced by a pull spring.

The orange lever and the pink crank oscillate with similar motion rules.

However loads applied to the pink crank of the spring mechanism may alter its motion rule.

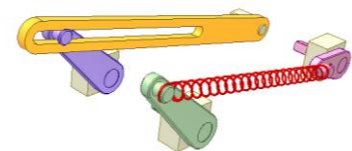

Equivalency of circular cam and linkage mechanisms 1

https://www.youtube.com/watch?v=AO_h10UqLIQ

Eccentricity of the green circular cam = length of the orange crank
Radius of cam pitch circle = length of the red conrod.

The blue follower and the yellow rocker have the same motion.

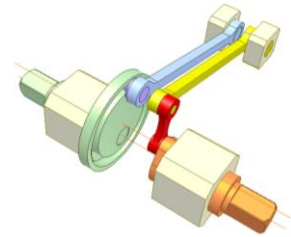

Equivalency of circular cam and linkage mechanisms 3

<https://www.youtube.com/watch?v=4DyP4Vo6cVU>

Eccentricity of the green circular cam = length of the orange crank
Radius of cam circle = length of the red conrod.

The blue follower and the yellow slider have the same motion.

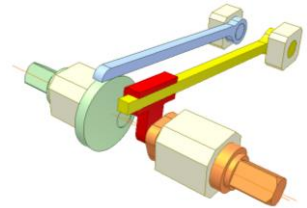

Equivalency of circular cam and linkage mechanisms 2

<http://youtu.be/DQB1pY3lt08>

Eccentricity of the green circular cam = length of the orange crank
Radius of cam pitch circle = length of the red conrod.

The blue follower and the yellow slider have the same motion.

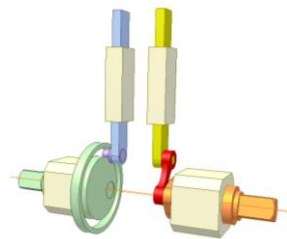

Equivalency of circular cam and linkage mechanisms 4

<http://youtu.be/DQB1pY3lt08>

Eccentricity of the green circular cam = length of the orange crank
Radius of cam circle = length of the red conrod.

The blue follower and the yellow slider have the same motion.

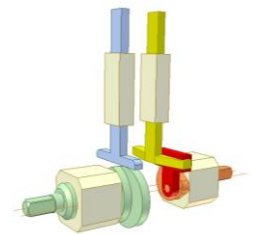

Study of planar ellipse mechanism 1

<http://youtu.be/M3hIMN--gAg>

Ellipse mechanism consists of a conrod and two sliders (in pink and yellow) connected together by revolution joints. The slider moves in straight grooves of a glass table. The table is movable and the conrod is stationary.

Input is the pink slider rotating continuously.

Pink and green curves are loci of points of the table in relation with the ground.

Orange curve is locus of a grounded point in relation with the table.

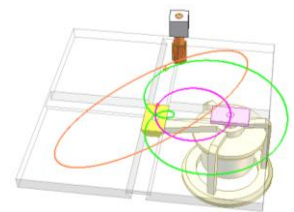

Ellipse mechanism 3a

<https://youtu.be/cu1JslGWgCk>

Input: blue shaft of two 90 deg. runways.

Output: pink slider linearly reciprocating. Its stroke length: AB

It moves as if it belongs to a slider-crank mechanism of crank

OR ($RA = RB$) and conrod RC.

Orange ellipse, green circle and violet ellipse are loci of points A, R and B respectively.

The loci are drawn 2 times in one revolution of the input.

One revolution of the input corresponds with two strokes of the pink slider.

This mechanism is numbered as 348 in the book "507 mechanical movements", 1868.

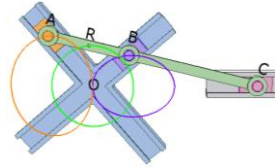

Scissor mechanism 1a

<https://youtu.be/KzYeW75-6Ww>

Input: pink crank driven by grey motor.

Output: red slider moving along a circular runway.

Blue circles are loci of middle pin centers.

Thanks to scissor mechanism there is no need to place the motor at the runway center.

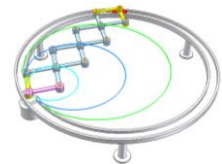

Scissor mechanism 1b

<https://youtu.be/R8JjJLC5diU>

Input: orange crank driven by green cylinder.

Output: red slider moving along a circular runway.

Small displacement of pink piston makes the red slider move long way.

Centers of the scissor middle joints almost follow the runway thanks to asymmetric links.

However the red slider can not move more than half of the runway circle.

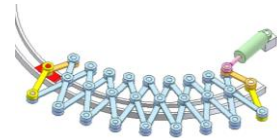

Scissor mechanism 1d

<https://youtu.be/lutSwph1VXk>

Scissor mechanism of asymmetric bars.

Input: red slider driven by green cylinder.

Small displacement of pink piston makes the mechanism almost closed.

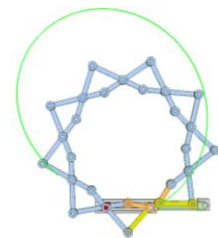

Scissor mechanism 1c

https://youtu.be/Xq7C_xGckQQ

Input: orange crank driven by grey motor.

Output: red slider moving along a zigzag runway.

This mechanism can be used for copying a curve.

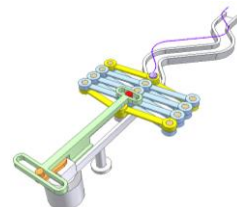

Mechanism creating two parallel runways

<https://youtu.be/aawNK1cr0Uc>

$$OB/OA = BP/AQ = OD/OC = DP/CQ$$

When pink crank rotates, two orange swivel runways are always parallel to each other.

This mechanism was numbered as 1314 in Artobolevski book, Mechanisms in modern technic, Moscow 1977, vol 2.

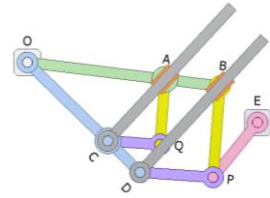

Disk cam of two followers

<https://youtu.be/EvJlcnKu0bQ>

Blue follower of the cam mechanism on the right moves easier than the one of the cam mechanism on the left thanks to adding rotary follower in pink.

The pressure angle on the left blue follower is higher than the one of the right blue follower.

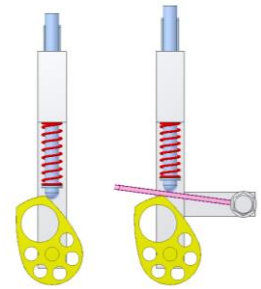

Circle rolling around square

<https://youtu.be/ctXyUoVV2c>

This video gives the answer for following problem:

A circle rolls without slip along perimeter of a square.

Diameter of the circle: D

Length of the square side: $\pi \cdot D$

(square perimeter = $4 \cdot$ circle circumference)

How many revolutions (N) the circle has to turn around its own rotary axis for completing 1 revolution around the square?

People may think that $N = 5$ because the circle needs to turn added $\frac{1}{4}$ rev. at every corner of the square.

The second scene of the video shows that the right answer is $N = 4$.

The circle is fixed to the circular gear.

The square is fixed to the pin square.

Rolling diameter of the circular gear of 20 teeth = D

Rolling perimeter of the pin square of 80 pins = $4 \cdot \pi \cdot D$

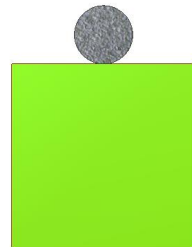

Rollers of Reuleaux polygon section

<https://youtu.be/UggVufPMKHo>

Rollers of Reuleaux polygons (in blue and pink) can be used like round rollers (in orange) because they are of constant width. The green plate moves absolutely horizontally.

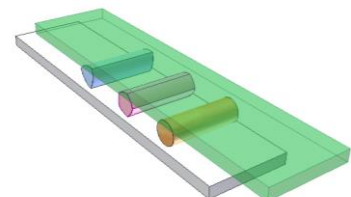

Balls of Reuleaux polygons

<https://youtu.be/pelInvRulA>

Balls of Reuleaux polygons (in blue and pink) can be used like round balls (in orange) because they are of constant width. The upper disk (forced down on the balls) rotates without vertical displacement and is kept always horizontal.

A ball of Reuleaux polygon is created from a polygon by rotating the polygon around its symmetric axis.

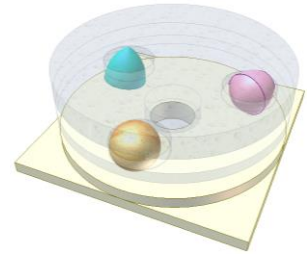

Chain drive of minimum number of links

<https://youtu.be/Yval9caJh5Y>

It aims at an answer to the question:

What is minimum number of links for a chain drive of transmission ratio of 1?

Each chain wheel has 4 teeth.

Number of links: 8

The simulation shows:

- Axle distance is nearly constant.
- Variation of output velocity (the blue chain wheel) is approximately 5% around nominal value.

An attempt for a chain drive of 3-tooth wheels, 7 links has been failed.

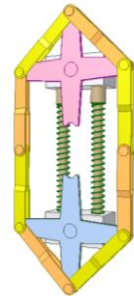

Isosceles triangle linkage

<https://youtu.be/wRsJYQ2P1pc>

AOC is an isosceles triangle ($AO = AC$). Length of side OC is variable.

The linkage ensures that $BO = BC$ always.

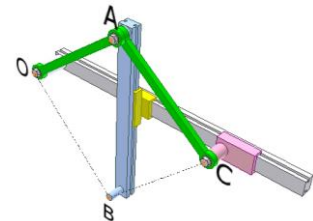

Kite mechanism 7

<https://youtu.be/AbrLSzVHTbc>

Kite OABC, $AO = AB$, $CO = CB$ can be varied in shape, but its diagonals are always perpendicular to each other.

AC is the bisector of OB

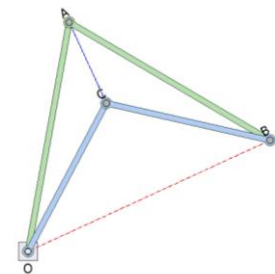

11.3. Spatial mechanisms

Spatial mechanism of two links

<https://youtu.be/XXxE3twlpA>

Input: rotary motion of blue slider-crank.

Output: reciprocating linear motion of the blue slider-crank.

Pink curve is the trajectory of center of spherical joint between the two links. It is the intersection of a spherical surface (its radius = length of green bar) and a cylindrical one (its radius = radius of the blue crank).

With some modifications it can be used for presses:

http://www.youtube.com/watch?v=613_NYKz68I

<https://youtu.be/kkpg8qo09yU>

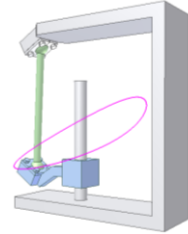

Space 4-bar mechanism 10

<http://youtu.be/q433oAXwHuU>

Bennett 4R mechanism

It is Bennett 4R mechanism (not spherical 4R mechanism)

4R: 4 revolute joints. It does not meet Kutzbach criterion.

The conditions that the mechanism must satisfy to be able to move:

1. The opposite sides of the mechanism (i.e. links that are not concurrent) have the same lengths, denoted by a, b.
2. The angles of twist are denoted by A, B and they are equal on opposite sides but with different sign.
3. The link lengths and link twist angles must satisfy the relation:
 $\sin A/a = \sin B/b$

For the blue and yellow (fixed) link: $a = 17.599$, $A = 15$ deg.

For the orange and green link: $b = 34$, $A = 30$ deg.



Space 4-bar mechanism 1

<http://youtu.be/9mcEF2s8QZU>

R-C-C-C mechanism. Input: the orange link. Output: the green link.

R-C-C-C: Joint symbols from input to output joint.

R: revolute

C: cylinder



Space 4-bar mechanism 2

<http://youtu.be/nK66lwNjG78>

P-C-C-C mechanism. Input: the orange link. Output: the green link.

P-C-C-C: Joint symbols from input to output joint.

P: prism

C: cylinder



Space 4-bar mechanism 3

<http://youtu.be/aUllcT74mXM>

H-C-C-C mechanism. Input: the orange link. Output: the green link.

H-C-C-C: Joint symbols from input to output joint.

H: helix

C: cylinder

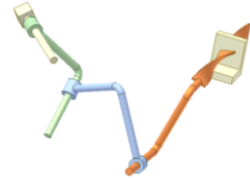

Space 4-bar mechanism 4

<http://youtu.be/xZcAUtW8XVc>

R-S-C-R mechanism. Input: the orange link. Output: the green link.

R-S-C-R: Joint symbols from input to output joint.

R: revolute

S: sphere

C: cylinder



Space 4-bar mechanism 5

<http://youtu.be/nJyS6zxSsMo>

R-S-C-P mechanism. Input: the orange link. Output: the green link.

R-S-C-P: Joint symbols from input to output joint.

R: revolute

S: sphere

C: cylinder

P: prism

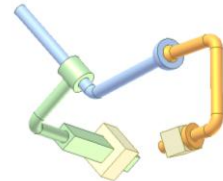

Space 4-bar mechanism 6

<http://youtu.be/Gg8Q6nUZc1c>

R-S-C-H mechanism. Input: the orange link. Output: the green link.

R-S-C-H: Joint symbols from input to output joint.

R: revolute

S: sphere

C: cylinder

H: helix

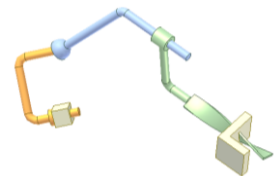

Space 4-bar mechanism 7

http://youtu.be/H_5D9wsdPM4

P-P-S-C mechanism. Input: the orange link. Output: the green link.

P-P-S-C: Joint symbols from input to output joint.

P: prism

S: sphere

C: cylinder



Space 4-bar mechanism 8

<http://youtu.be/4k5WcYcqoQg>

R-H-C-H mechanism. Input: the orange link. Output: the green link.

R-H-C-H: Joint symbols from input to output joint.

R: revolute

H: helix

C: cylinder

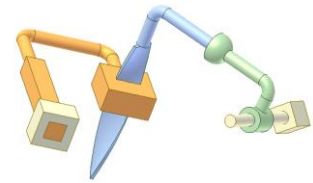

Space 4-bar mechanism 9

<http://youtu.be/aiAdhly2Guo>

H-H-S-C mechanism. Input: the orange link. Output: the green link.

H-H-S-C: Joint symbols from input to output joint.

H: helix

S: sphere

C: cylinder

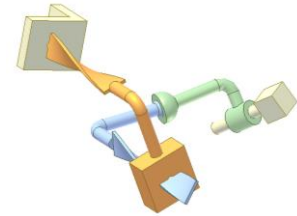

Space 4-bar mechanism 12

http://youtu.be/m0xG_u63WH0

R-C-C-R mechanism

R-C-C-R: Joint symbols from input to output joint.

R: revolute

C: cylinder

It does not meet Kutzbach criterion.

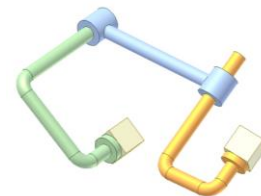

Space 4-bar mechanism 13

<http://youtu.be/ccvYpANAWPE>

P-C-C-P mechanism

P-C-C-P: Joint symbols from input to output joint.

P: prism

C: cylinder

It does not meet Kutzbach criterion.

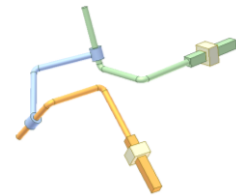

Study of Cardan universal joint 1

<http://youtu.be/ZQt6cAmsgXQ>

Universal joints allow to adjust A angle between input and output shafts even during rotary transmission. This case shows ± 45 deg regulation. It is clear that single Cardan joint is not of constant velocity when A differs from 0 deg..

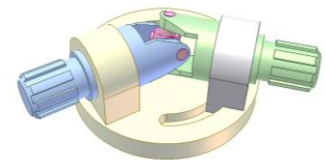

Study of double cardan universal joint 1a

http://youtu.be/gBoJT_PI-RA

Double Cardan drives allow to adjust relative linear positions between the input and output shafts even during rotary transmission. The output velocity is always equal to the input one (constant velocity joint) because their shafts are kept parallel each other.

The pin axles on the intermediate half shafts (in yellow and in violet) must be parallel each other.

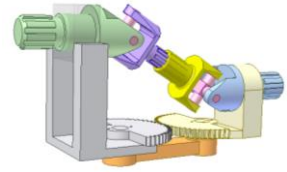

Study of double cardan universal joint 1b

<http://youtu.be/4CYnLyTsYOA>

This is wrong case of a double Cardan joint: the pin axles on the intermediate half shafts (in yellow and in violet) are perpendicular each other.

The joint loses the feature of velocity constant when the input and output shafts are not in a straight line although they are kept parallel each other.

So pay attention to assembling the intermediate shaft.

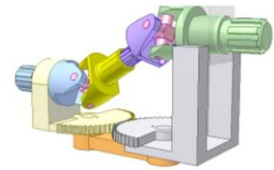

Study of double Cardan universal joint 2a

<http://youtu.be/cydmR0IX2t8>

Double Cardan joints allow to adjust angle A between input and output shafts even during rotary transmission. This case shows +/- 90 deg regulation and proves that double Cardan joints are of constant velocity.

Due to the gear planetary drive of two gear sectors and orange crank, angle between input (or output) shaft and the yellow intermediate shaft is always equal to $A/2$.

The pin axles on the yellow-violet intermediate shaft must be parallel each other.

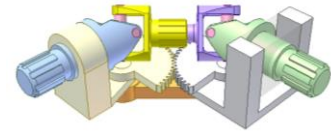

Study of double Cardan universal joint 2b

<http://youtu.be/lttUsogU4AQ>

This is wrong case of a double Cardan joint: the pin axles on the yellow-violet intermediate shaft are perpendicular each other.

Although due to the gear planetary drive of two gear sectors and orange crank, angle between input (or output) shaft and the yellow intermediate shaft is always equal to $A/2$ (A is angle between input and output shafts),

The joint loses the feature of velocity constant when the input and output shafts are not in a straight line (A differs from 0 deg.).

So pay special attention to assembling the intermediate shaft.

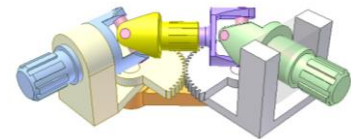

Study of double Cardan universal joint 3

<http://youtu.be/Qf88nPtm2h4>

Double Cardan joints allow to adjust relative positions between the input and output shafts even during rotary transmission. This is the case when the input and output shafts are skew. The joint loses the feature of velocity constant. The output velocity is not constant.

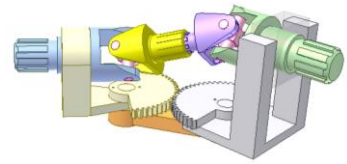

Study of spatial parallelogram mechanism 1a

<http://youtu.be/uP6lyI5OqtY>

There are two spatial parallelogram mechanisms (lengths of opposite links are equal).

For the left one of 4 spherical joints the opposite links may be not parallel during motion.

For the right one of 2 spherical and 2 revolute joints the opposite links are always parallel. Direction of longitudinal axis of the yellow conrod is kept unchanged during motion.

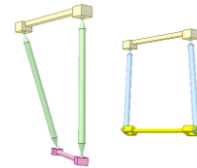

Study of spatial parallelogram mechanism 1b

<http://youtu.be/DgVxKULp6zE>

Blue and green rockers, yellow conrod and the base create a parallelogram.

The two rockers are connected to the base by universal joints of 2 degrees of freedom.

The yellow conrod is connected to the green rocker by a revolute joint and to the blue rocker by a spherical joint.

The mechanism has two degrees of freedom (by computer testing) so two actuators are needed for controlling two pink frames.

Longitudinal axis direction of the yellow conrod is kept unchanged during motion. However its upper surface is not kept always horizontal.

The yellow conrod with two revolute joints has been tested but no success.

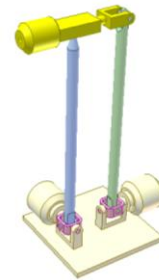

Study of spatial parallelogram mechanism 1c

<http://youtu.be/KyBAXmBmYA>

Long bars are identical.

Short bars are identical.

Brown bars are fixed.

All joints are spherical.

The video shows 4 mechanisms during motion.

1. The yellow one in general can not always give a parallelogram.
2. The blue one in general can not always give a parallelogram.
3. The green one always gives a variable parallelogram (distance between two long bars is variable).
4. The pink one of one DoF always gives a stable, invariable parallelogram.

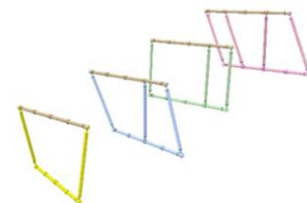

Study of spatial parallelogram mechanism 2a

<http://youtu.be/qnFIFyQqdm0>

Lower and upper regular triangle plates are identical.

Green vertical bars are identical.

All joints are spherical.

When the upper plate moves, it may not be parallel to the lower plate.

Computer testing shows that the mechanism has 3 degrees of freedom (DoF) excluding passive DoF (rotation of each bar around the line joining its two joints).



Study of spatial parallelogram mechanism 2b

<http://youtu.be/R38F202W0eY>

Lower and upper plates are identical.

Green vertical bars are identical.

All joints are spherical.

Distance between two joints of the plates and of yellow horizontal bar are equal.

In general lower and upper plates are kept parallel but there is the case shown in this video.

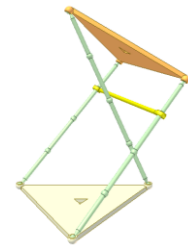

Study of spatial parallelogram mechanism 2c

<http://youtu.be/tttYnzX1t74>

Lower and upper plates are identical.

Green vertical bars are identical.

All joints are spherical.

Distance between two joints of the plates and of yellow horizontal bars are equal.

Lower and upper plates are always parallel.

Computer testing shows that the mechanism has 2 degrees of freedom (DoF) excluding passive DoF (rotation of each bar around the line joining its two joints)..

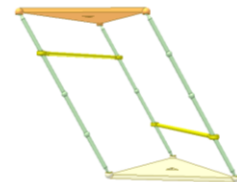

Spatial parallelogram mechanism 1

<https://youtu.be/Cc70nsa3Oug>

It is an application of double Cardano joints.

The joint is shown at:

<https://youtu.be/95bZU6yIEzw>

The direction of upper disk is kept unchanged and its surface is kept always horizontal.

Each point of the disk moves on a spherical surface.

See a similar mechanism where the upper disk can be controlled by grounded motors:

<http://youtu.be/iQ5TkU04Xdc>

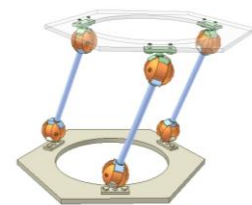

Double spatial parallelogram mechanism 1

https://youtu.be/OdCJRpMf_78

It is developed from the mechanism shown at

<https://youtu.be/Cc70nsa3Oug>

The upper disk can move in any direction. Its direction is kept unchanged and its surface is kept always horizontal. Green line is the trajectory of the upper disk center in this animation.

If the upper disk is driving, the middle disk moves in 3 directions unstably. In this animation one is restricted.

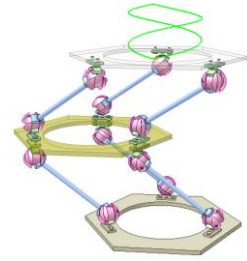

Study of ellipse mechanism on a sphere 1

<http://youtu.be/D7Vu3OqEztE>

Ellipse mechanism consists of a conrod and two sliders.

The sliders moves in two 90 deg. crossed grooves.

The conrod is driving link. Angle between its revolution joints is 75 deg.

Two sliders oscillate around the same groove intersection.

The closed curves are loci of various points on the conrod.

In case on a planar ellipse mechanism they are ellipses.

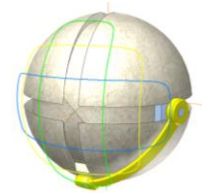

Study of ellipse mechanism on a sphere 2

http://youtu.be/_8M_R3_YzsY

Ellipse mechanism consists of a conrod and two sliders.

The sliders moves in two 90 deg. crossed grooves.

The conrod is driving link. Angle between its revolution joints is 100 deg.

The closed curves are loci of various points on the conrod.

Two sliders oscillate around different groove intersections.

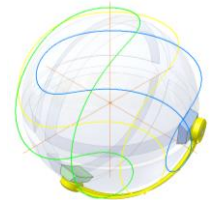

Study of ellipse mechanism on a sphere 3

<http://youtu.be/eTE8UDZ-W80>

Ellipse mechanism consists of a conrod and two sliders.

The sliders moves in two 90 deg. crossed grooves.

The conrod is driving link. Angle between its revolution joints is 200 deg.

The closed curves are loci of various points on the conrod.

Two sliders oscillate around different groove intersections.



Study of ellipse mechanism on a sphere 4

<http://youtu.be/MKlwhTOJzYc>

This is an application of ellipse mechanism on a sphere and can be seen as a kinetic art sculpture.

Input is the green slider rotating regularly.

Output: the sphere rotating around its center point, not center axis.

The conrod is stationary. Angle between its revolution joints is 120 deg.

The sliders moves in two 90 deg. crossed grooves.

The sphere can be of other material: glass, plastic, stone, wood.



Study of four leg chair

<https://youtu.be/AUnPILFOiYI>

A revolute joint of two front legs ensures the permanent contact of four legs with an uneven floor. It happens only in case the vertical load (represented by red arrow) is applied inside the green triangle. Otherwise only three legs are in contact with the floor.



11.4. Springs

Adjusting force of a tension spring 1

<https://youtu.be/aDkSIFBwsSM>

Turn yellow nut to increase or reduce tension force applied to axle pins of grey parts.

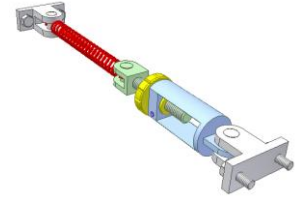

Adjusting force of a compression spring 1

<https://youtu.be/ZbpacL9NOdM>

Turn yellow nut to increase or reduce compression force applied to axle pins of grey parts.

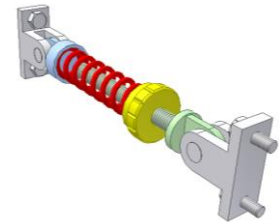

Using compression spring to bear tension 1

<http://youtu.be/KU4JKCrpjGw>

Reason: the hooks of a extension spring are difficult for production and easy to be broken in operation.

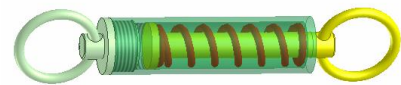

Using compression spring to bear tension 2

<http://youtu.be/7QWof76HuXs>

Reason: the hooks of a extension spring are difficult for production and easy to be broken in operation.

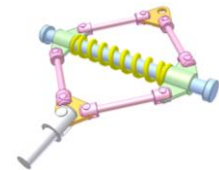

Using compression spring to bear tension 3

<https://youtu.be/HbW7QeQUkWc>

Turn grey nut to increase or reduce tension force applied to the ends of blue and yellow parts.

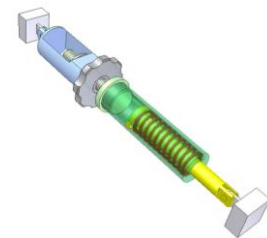

Spring increased tension

http://youtu.be/m_XVJT-4T4o

Increased tension for the same movement is gained by providing a movable spring mount and gearing it to the other movable lever.

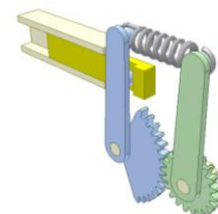

Constant tension from spring 1

<http://youtu.be/YzvwYgNOH0>

The spring force applied along the orange slider is nearly constant because when the spring length is increased, the action radius of spring force around the pivot of green lever is reduced.

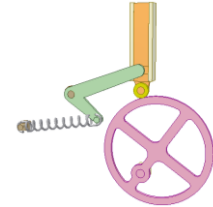

Constant tension from spring 2

<http://youtu.be/W8R-BN6WXXg>

Spring constant tension for large movement of the green lever is gained by providing a movable spring mount on the blue lever that is controlled by the yellow stationary cam.

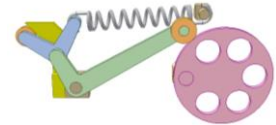

Spring combination 2

<http://youtu.be/HX0Rd2NpduY>

This compressing mechanism has a dual rate for double-action compacting. In one direction pressure is high, but in the reverse direction pressure is low.



Spring combination 1

<http://youtu.be/UOnMKvGGW3U>

This mechanism provides a three-step rate change at predetermined positions. The lighter springs will always compress first, regardless of their position.

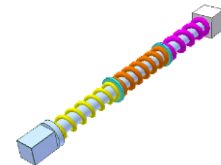

Spring damping mechanism 1

<http://youtu.be/qaHBqI6ycaE>

Two springs at both sides of a piston play anti-shock role well.

